

SECTIONAL DIRECTIONAL  
CONTROL VALVES

SD 6

DS 7

## *SD6*

Simple, compact and heavy duty designed sectional valve from 1 to 12 sections for open and closed centre hydraulic systems.

- Fitted with a main pressure relief valve and a load check valve on every working section
- Available with parallel, tandem or series circuit.
- Optional carry-over port.
- A wide variety of port and circuit valves.
- Available manual, pneumatic, hydraulic, electro-hydraulic, and remote with flexible cables spool control kits.
- Diameter 16 mm (*0.63 in*) interchangeable spools.

## *DLS7*

They are for systems with fixed displacement pumps (open centre version), or variable displacement pumps (closed centre version), with Load-Sensing signal on each working section to pump flow control valve control.

- Load-independent flow control.
- Ports valves and "B" side control kits are the same of SD6 directional valve.
- L.S. signal connections on every working section.

### **Additional information**

This catalogue shows the product in the most standard configurations.  
Please contact Sales Dpt. for more detailed information or special request.

### **WARNING!**

All specifications of this catalogue refer to the standard product at this date.  
Walvoil, oriented to a continuous improvement, reserves the right to discontinue, modify or revise the specifications, without notice.

WALVOIL IS NOT RESPONSIBLE FOR ANY DAMAGE CAUSED BY AN  
INCORRECT USE OF THE PRODUCT.

2<sup>nd</sup> edition December 2006:

**This edition supercedes all prior documents.**

Working conditions .....	4
SD6 directional valve .....	7
DLS7 Load Sensing directional valve .....	73
Installation and maintenance .....	94
Accessories .....	98

## Working conditions

This catalogue shows technical specifications and diagrams measured with mineral oil of 46 mm<sup>2</sup>/s - 46 cSt viscosity at 40°C temperature.

### SD6

Nominal flow rating		45 l/min	
Operating pressure (max.)	<i>parallel or tandem circuit</i>	315 bar	4600 psi
	<i>series circuit</i>	210 bar	3050 psi
Back pressure (max.)	<i>on outlet port T</i>	25 bar	360 psi
Internal leakage A(B)→T	<i>Δp=100 bar - 1450 psi fluid and valve at 40°C</i>	3 cm <sup>3</sup> /min *	0.18 in <sup>3</sup> /min *

### DLS7

Nominal flow rating (with 14 bar / 200 psi stand-by)	<i>on inlet port P</i>	75 l/min	
	<i>on ports A and B</i>	60 l/min	
Operating pressure (max.)		315 bar	4600 psi
Back pressure (max.)	<i>on outlet port T</i>	25 bar	360 psi
Internal leakage A(B)→T	<i>Δp=100 bar - 1450 psi fluid and valve at 40°C</i>	3 cm <sup>3</sup> /min *	0.18 in <sup>3</sup> /min *

Fluid		Mineral based oil	
Fluid temperature	<i>with NBR (BUNA-N) seals</i>	from -20° to 80°C	
	<i>with FPM (VITON) seals</i>	from -20° to 100°C	
Viscosity	<i>operating range</i>	from 15 to 75 mm <sup>2</sup> /s	<i>from 15 to 75 cSt</i>
	<i>min.</i>	12 mm <sup>2</sup> /s	12 cSt
	<i>max.</i>	400 mm <sup>2</sup> /s	400 cSt
Max level of contamination		-/19/16 - ISO 4406	
Ambient temperature	<i>with mechanical devices</i>	from -40° to 60°C	
	<i>with pneumatic and hydraulic devices</i>	from -30° to 60°C	
	<i>with electric devices</i>	from -20° to 50°C	
Tie rods tightening torque (wrench 13)		30 Nm	22 lbf <sup>t</sup>

NOTE (\*) - Except differently specified inside the catalogue.

NOTE - For different conditions please contact Sales Dept.

**Standard threads**
**REFERENCE STANDARD**

		BSP	UN-UNF	METRICA	NPTF
THREAD ACCORDING TO		ISO 228/1	ISO 263	ISO 262	ANSI B1.20.3
		BS 2779	ANSI B1.1 unified		
CAVITY DIMENSION ACCORDING TO	ISO	1179	11926	9974-1	
	SAE		J1926	J2244	J476a
	DIN	3852-2 shape X or Y		3852-1 shape X or Y	

**PORTS THREADING**
**SD6**

PORTS	BSP	UN-UNF	METRICA
Inlet <b>P</b>	G 3/8	3/4-16 (SAE 8)	M18x1.5
Working ports <b>A</b> and <b>B</b>	G 3/8	9/16-18 (SAE 6)	M18x1.5
Outlet <b>T</b> and carry-over <b>C</b>	G 1/2	3/4-16 (SAE 8)	M22x1.5
<b>PILOT PORTS</b>			
Hydraulic ports	G 1/4	9/16-18 (SAE 6)	G 1/4
Pneumatic ports	NPTF 1/8-27	NPTF 1/8-27	NPTF 1/8-27

**DLS7**

PORTS	BSP	UN-UNF
Inlet <b>P</b> and outlet <b>T</b>	G 1/2	3/4-16 (SAE 8)
Working ports <b>A</b> and <b>B</b>	G 3/8	9/16-18 (SAE 6)
Load Sensing signal <b>LS</b>	G 1/4	9/16-18 (SAE 6)
<b>PILOT PORTS</b>		
Hydraulic ports	G 1/4	9/16-18 (SAE 6)
Pneumatic ports	NPTF 1/8-27	NPTF 1/8-27





## Content

Dimensional data .....	8
Hydraulic circuit .....	9
Performance data .....	11
Ordering codes .....	12
Inlet cover	
ordering codes .....	14
dimensional data and hydraulic circuit .....	15
inlet relief options .....	16
inlet valve options .....	17
R2 commutator configuration .....	19
S flow regulator configuration .....	20
Working section	
ordering codes .....	22
dimensional data and hydraulic circuit .....	24
spools .....	25
“A” side spool positioners .....	32
“B” side options .....	49
complete controls .....	54
port valves .....	59
Intermediate section	
CS1 mid return manifold section .....	64
DFG compensated flow divider section .....	65
EI service relief valve section .....	66
EVP9 compensated flow control section .....	67
EVP3 inlet section with regulated flow .....	68
Outlet cover	
ordering codes .....	70
dimensional data and hydraulic circuit .....	71

**Dimensional data (series or tandem circuit)**

Carry-over configuration

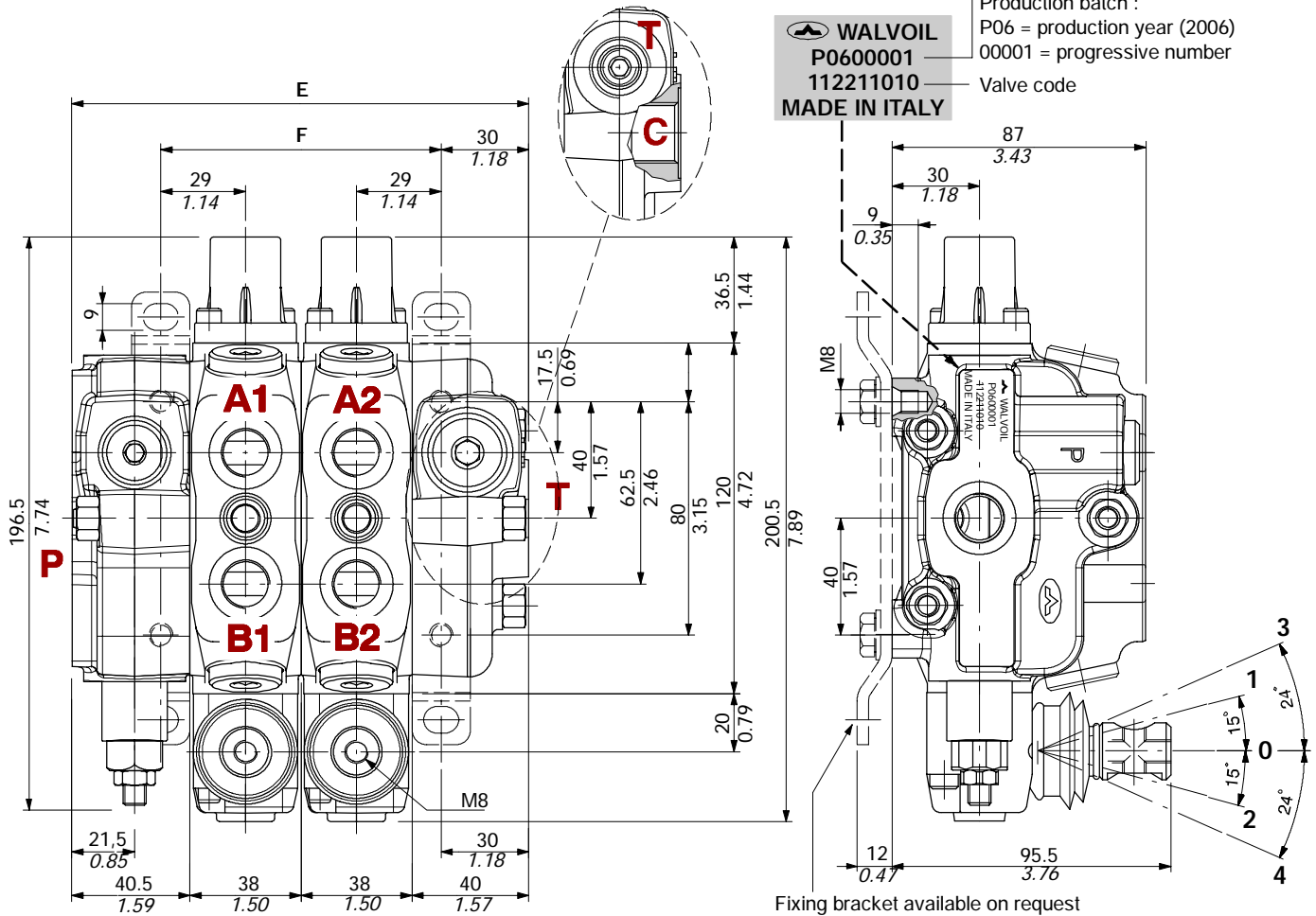

TYPE	E		F		Weight	
	mm	in	mm	in	kg	lb
SD6/1	118.5	4.66	58	2.28	5.3	11.7
SD6/2	156.5	6.16	96	3.78	7.6	16.6
SD6/3	194.5	7.66	134	5.28	9.9	21.8
SD6/4	232.5	9.15	172	6.77	12.2	26.9
SD6/5	270.5	10.65	210	8.27	14.8	32.6
SD6/6	308.5	12.15	248	9.76	17.1	37.7

TYPE	E		F		Weight	
	mm	in	mm	in	kg	lb
SD6/7	346.5	13.65	286	11.26	19.4	42.8
SD6/8	384.5	15.15	324	12.76	21.7	47.9
SD6/9	422.5	16.65	362	14.26	24	53
SD6/10	460.5	18.15	400	15.76	26.3	58.1
SD6/11	498.5	19.65	438	17.26	28.6	63.2
SD6/12	536.5	21.15	476	18.76	30.9	68.3

**Parallel circuit**

Standard configuration with open centre and side inlet and outlet.

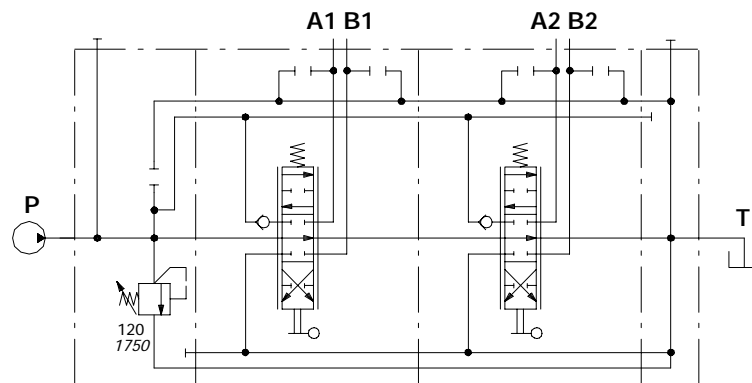
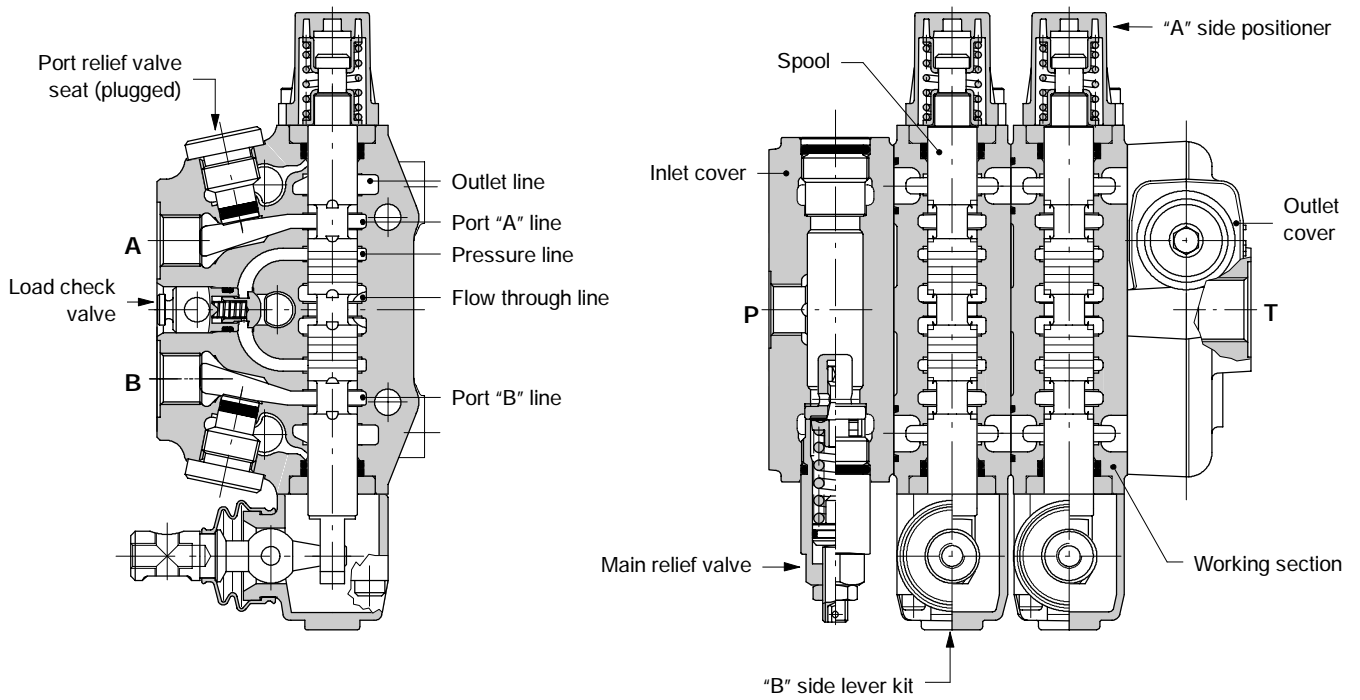

Description example: SD6/2/AC(YG3-120)/18L/18L/RC

Hydraulic circuit

Series-parallel (tandem) circuit

It needs a special working section kit (see page 22)  
 Tandem section is fed from thr free flow pressure line; it's excluded when an up strem section is operated.

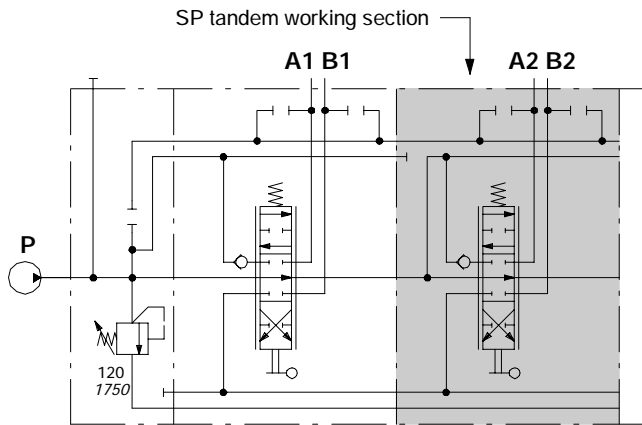

Description example:  
 SD6/2/AC(YG3-120)/18L/SP-18L/....

Series circuit

It needs a special working section kit (see page 22).  
 The return oil from service ports feed the remaining down stream sections.

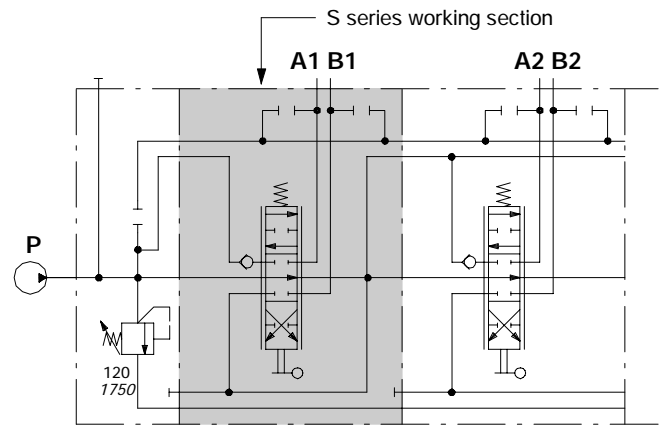

Description example:  
 :SD6/2/AC(YG3-120)/S-18L/P-18L/....

Right inlet directional valve

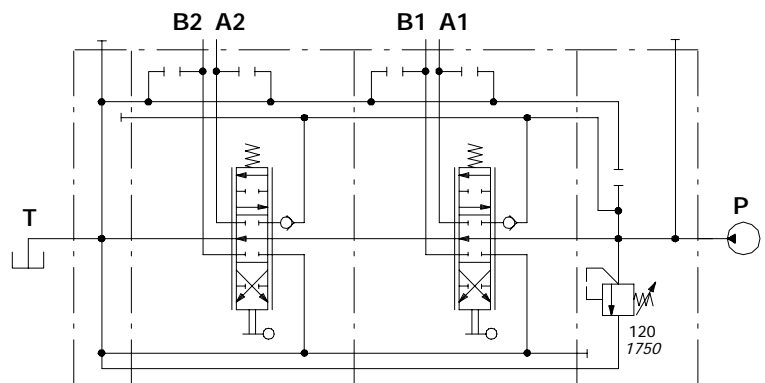
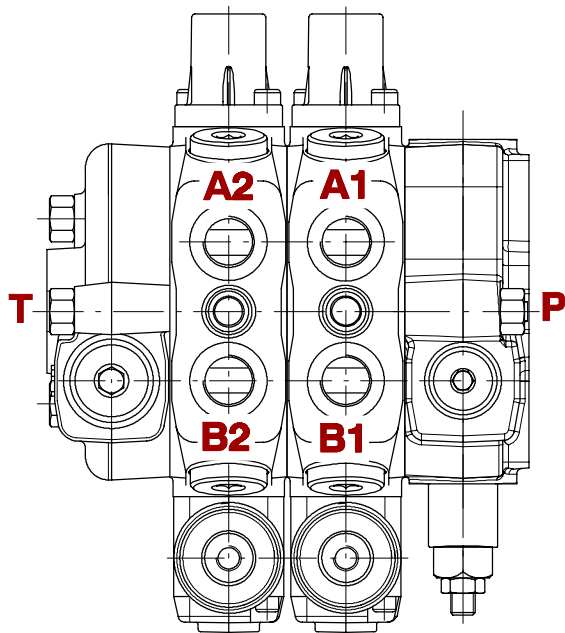

Description example:  
 SD6/2/BC(YG3-120)/18L/18L/RC

**Performance data (pressure drop vs. flow)**

**Open centre**

From side inlet to side outlet.

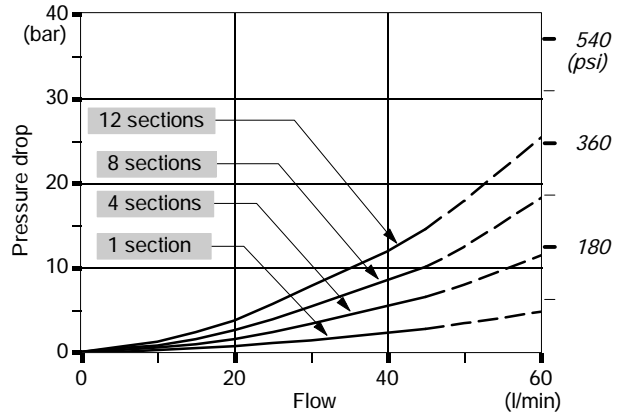
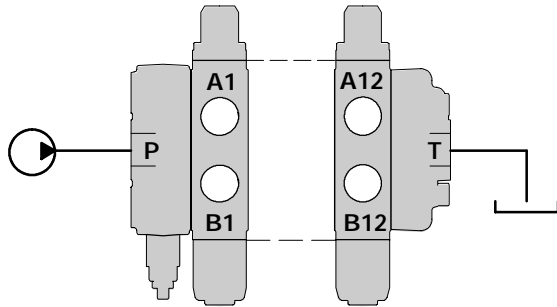

**Inlet to work port**

From side inlet to A port (spool in position 1) or B port (spool in position 2).

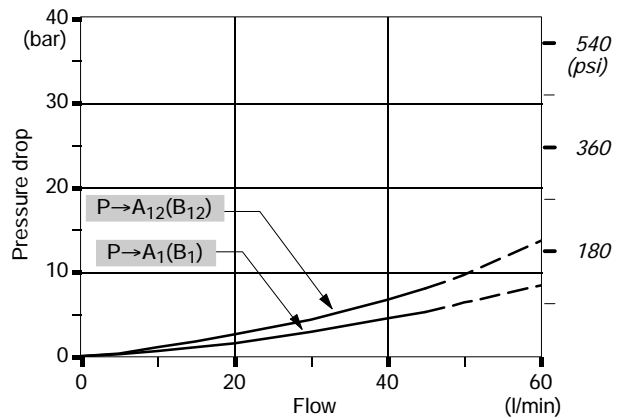
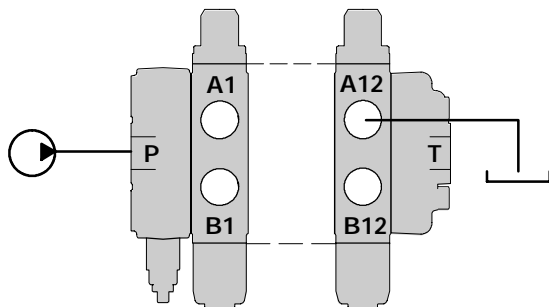

**Work port to outlet**

From A port (spool in position 2) or B port (spool in position 1) to side outlet.

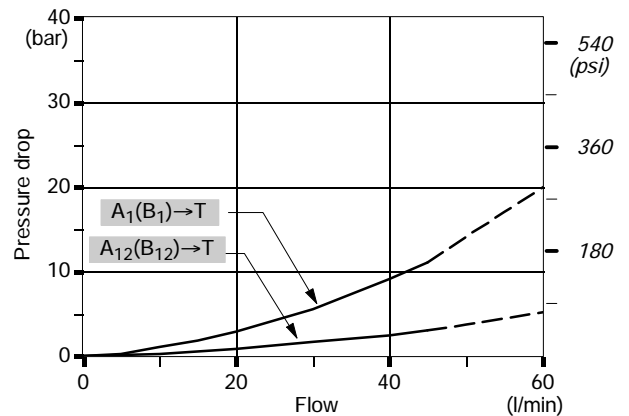
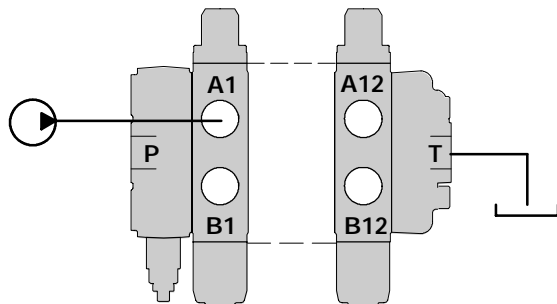

NOTE - Measured with spool type 1.

## Ordering codes

Description example: standard configuration with side inlet and outlet

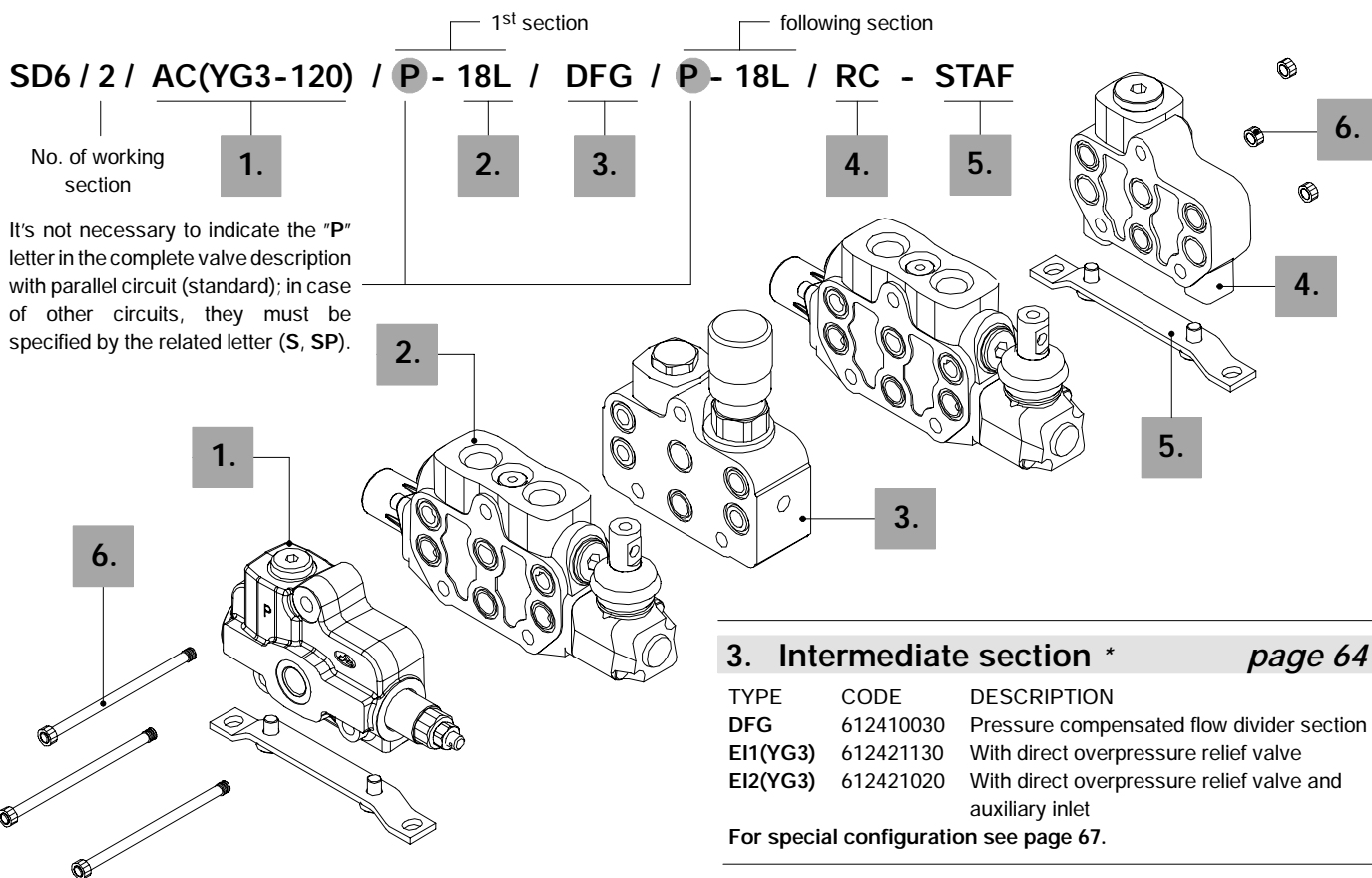

### 1. Complete inlet cover \* page 14

TYPE	CODE	DESCRIPTION
AC(JG3-120)	612201171	Side inlet with VMDJ direct pressure relief valve
AC(YG3-120)	612201110	Side inlet with VMDY direct pressure relief valve
AD(YG3-120)	612201120	Upper inlet with VMDY direct pressure relief valve

For special configuration see page 19.

### 2. Complete working section\* page 22

TYPE	CODE	DESCRIPTION
P-18L	612101001	Parallel circuit, prearranged for port valves, double acting spool with spring return, lever control
S-18L	612111001	As previous with series circuit
SP-18L	612121001	As previous with series-parallel (tandem) circuit

NOTE - For covers and sections description composition see related pages.

NOTE (\*) - Items are referred to **BSP** thread.

### 3. Intermediate section \* page 64

TYPE	CODE	DESCRIPTION
DFG	612410030	Pressure compensated flow divider section
EI1(YG3)	612421130	With direct overpressure relief valve
EI2(YG3)	612421020	With direct overpressure relief valve and auxiliary inlet

For special configuration see page 67.

### 4. Complete outlet cover \* page 70

TYPE	CODE	DESCRIPTION
RC	612300110	Side outlet
RD	612300120	Upper outlet
RE	612300114	Upper outlet with side carry-over
RK	612300117	Upper outlet with closed centre

### 5. Fixing bracket page 99

TYPE	CODE	DESCRIPTION
STAF	5STA120160	Brackets with fixing screws

### 6. Assembling kit

CODE	DIRECTIONAL VALVE
5TIR108117	Tie rod kit for 1 section valve
5TIR108155	Tie rod kit for 2 sections valve
5TIR108193	Tie rod kit for 3 sections valve
5TIR108231	Tie rod kit for 4 sections valve
5TIR108269	Tie rod kit for 5 sections valve
5TIR108307	Tie rod kit for 6 sections valve
5TIR108345	Tie rod kit for 7 sections valve
5TIR108383	Tie rod kit for 8 sections valve
5TIR108421	Tie rod kit for 9 sections valve
5TIR108459	Tie rod kit for 10 sections valve
5TIR108497	Tie rod kit for 11 sections valve
5TIR108535	Tie rod kit for 12 sections valve

Description example: configuration with 2 side inlets and mid return manifold:

SD6 / 2 / AC(YG3-120) / P - 18L / CS1 / P - ED - 18L / BC(YG3-120) - STAF

1<sup>st</sup> section
following section

1.
2.
8.
9.
10.
5.

No. of working section

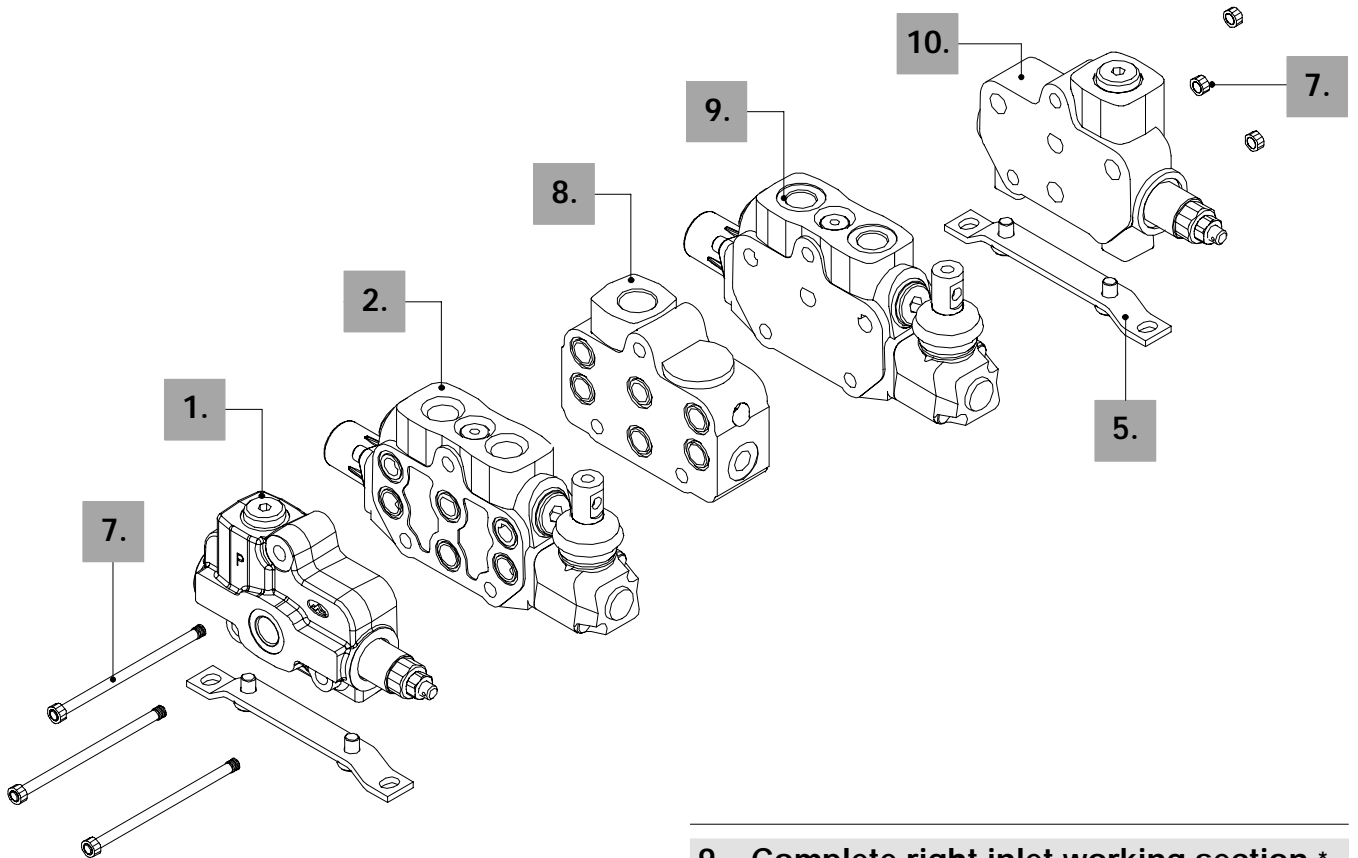

### 7. Assembling kit for valve with CS1

CODE	DIRECTIONAL VALVE (with CSMT)
5TIR108193	Tie rod kit for 2 sections valve (with CS1)
5TIR108231	Tie rod kit for 3 sections valve (with CS1)
5TIR108269	Tie rod kit for 4 sections valve (with CS1)
5TIR108307	Tie rod kit for 5 sections valve (with CS1)
5TIR108345	Tie rod kit for 6 sections valve (with CS1)
5TIR108383	Tie rod kit for 7 sections valve (with CS1)
5TIR108421	Tie rod kit for 8 sections valve (with CS1)
5TIR108459	Tie rod kit for 9 sections valve (with CS1)
5TIR108497	Tie rod kit for 10 sections valve (with CS1)

### 8. Return manifold page 64

TYPE	CODE	DESCRIPTION
CS1	612400010	Mid return manifold with G1/2 outlet port

### 9. Complete right inlet working section \*

TYPE	CODE	DESCRIPTION
P-ED-18L	612101048	Parallel circuit, prearranged for port valves, double acting spool with spring return, lever control
S-ED-18L	612111017	As previous with series circuit
SP-ED-18L	612121003	As previous with series-parallel (tandem) circuit

### 10. Complete right inlet cover \*

TYPE	CODE	DESCRIPTION
BC(JG3-120)	612201117	Side inlet with VMDJ direct pressure relief valve
BC(YG3-120)	612201130	Side inlet with VMDY direct pressure relief valve
BD(YG3-120)	612201115	Upper inlet with VMDY direct pressure relief valve

For special configuration see page 19.

NOTE (\*) - Items are referred to **BSP** thread; sections and covers for right inlet are different from the standard (see ref. 1 e 2) because of different components assembling

## Ordering codes

### Description example:

FE SD6 / AC (YG3 - 120) ELT - MAN1/4 - 12VDC \*

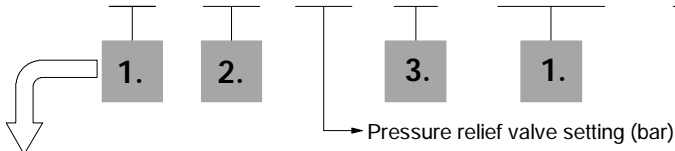

### Available configurations

- AC: with side inlet, for left inlet (standard) directional valve
  - AD: with upper inlet, for left inlet (standard) directional valve
  - BC: with side inlet, for right inlet directional valve
  - BD: with upper inlet, for right inlet directional valve
- See page 15.

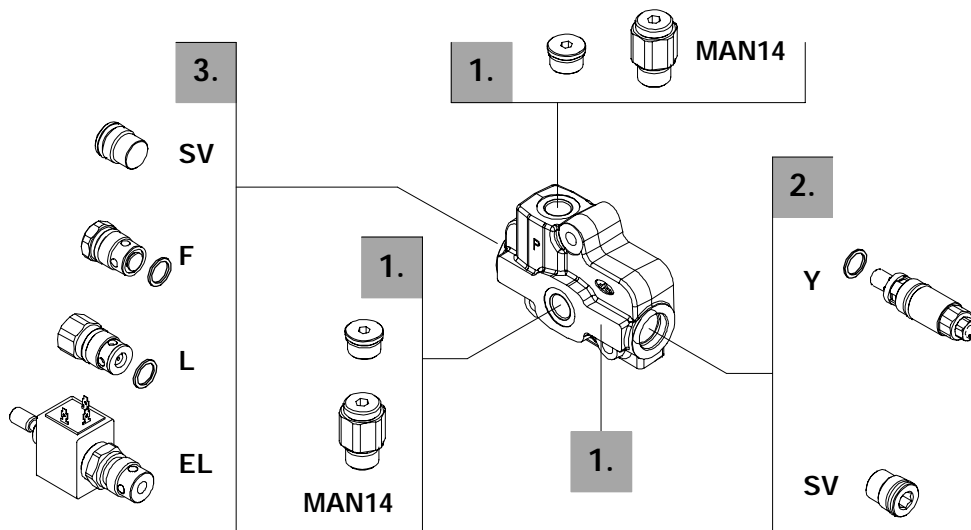

### 1. Inlet cover body \* page 15

CODE	DESCRIPTION
3FIA106302+3XTAP722160	Standard
3FIA106302+5MAN621200	With G1/8 pressure gauge prearrangement
3FIA106302+5MAN622320	With G1/4 pressure gauge prearrangement

### 3. Inlet valve options page 17

TYPE	CODE	DESCRIPTION
F	5KIT406200	Inlet anti-cavitation valve
L	5KIT406300*	Hydraulic pilot unloader valve
ELT	5CAR406306	12 VDC electromagnetic controlled unloader valve
	5CAR406311	24 VDC electromagnetic controlled unloader valve
SV	XTAP623282	Relief valve blanking plug

### 2. Inlet relief options page 16

TYPE	CODE	DESCRIPTION
<u>VMD5/1 balanced direct pressure relief valve type Y</u>		
(YG2)	5KIT105212	Range 63 to 125 bar / 900 to 1800 psi standard setting 80 bar / 1150 psi
(YG3)	5KIT105213	Range 100 to 200 bar / 1450 to 2900 psi standard setting 120 bar / 1750 psi
(YG4)	5KIT105214	Range 160 to 315 bar / 2300 to 4600 psi standard setting 250 bar / 3600 psi

Standard setting is referred to 10 l/min flow.

SV XTAP623282 Relief valve blanking plug

Direct pressure relief valve type J is available on request: contact Customer Service

(JG2)	5KIT105412	Range 40 to 80 bar / 580 to 1150 psi standard setting 80 bar / 1150 psi
(JG3)	5KIT105413	Range 63 to 200 bar / 900 to 2900 psi standard setting 120 bar / 1750 psi
(JG4)	5KIT105414	Range 160 to 315 bar / 2300 to 4600 psi standard setting 220 bar / 3200 psi

NOTE (\*) - Items are referred to **BSP** thread.

**Dimensional data and hydraulic circuit**

**For left inlet directional valve (standard)**

**With side inlet, type AC**

Allen wrench 6  
24 Nm / 17.7 lbft

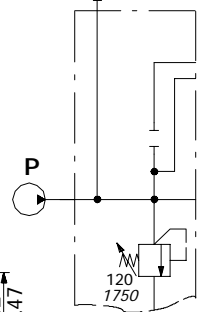
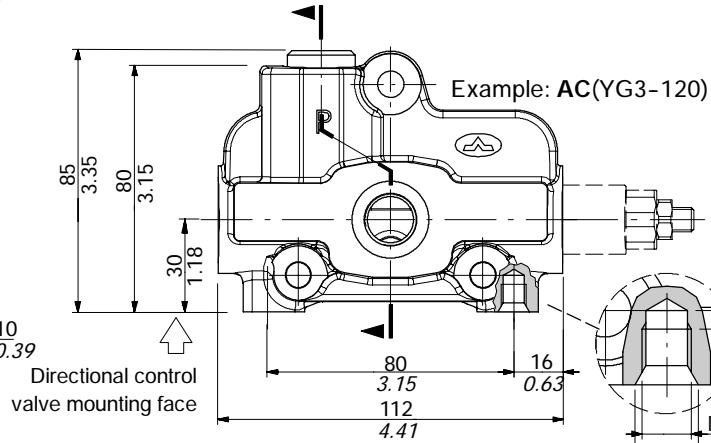
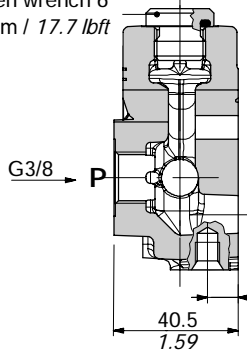

**With upper inlet, type AD**

Allen wrench 6  
24 Nm / 17.7 lbft

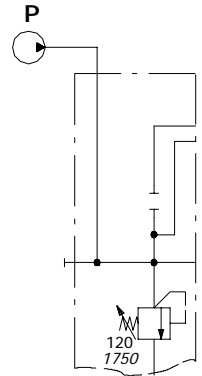
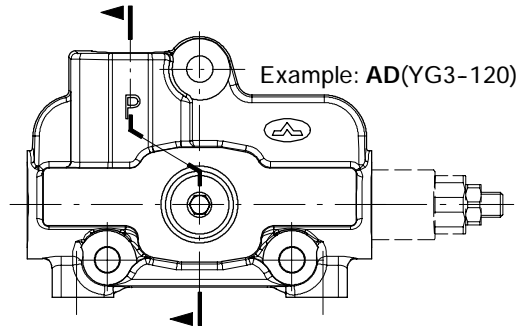
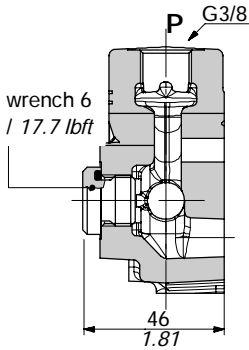

**For right inlet directional valve**

**With side inlet, type BC**

Allen wrench 6  
24 Nm / 17.7 lbft

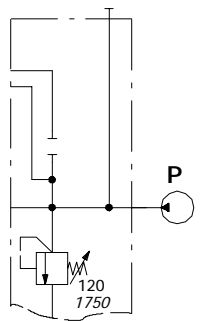
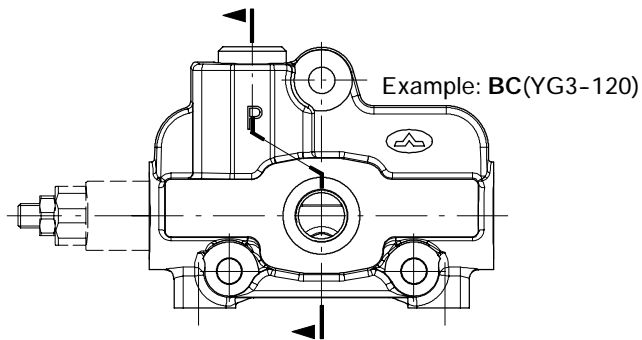
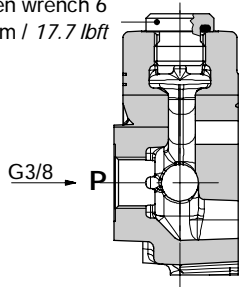

**With upper inlet, type BD**

Allen wrench 6  
24 Nm / 17.7 lbft

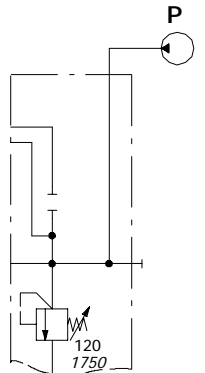
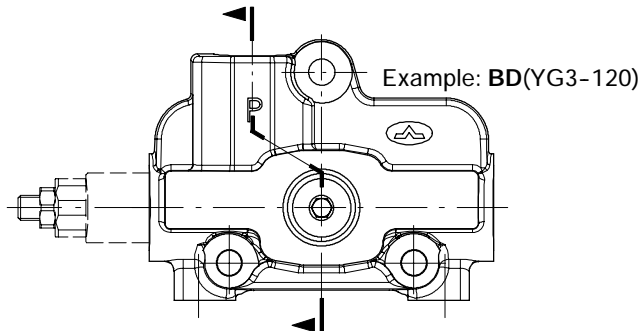
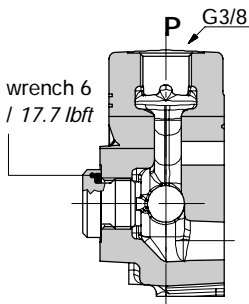

Inlet relief options

Direct overpressure relief valve

VMD5 ( Y G 3 - 120 )

- Pressure setting in bar (for standard value see page 14)
- Adjustable spring type (2, 3, 4).
- Adjustment type (G, H)

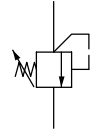

Adjustment type

G: with screw

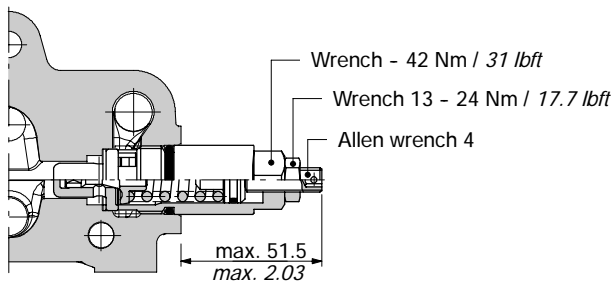

H: valve set and locked

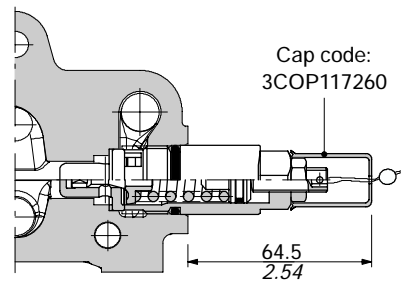

Performance data

Spring nr. 2 (green band)

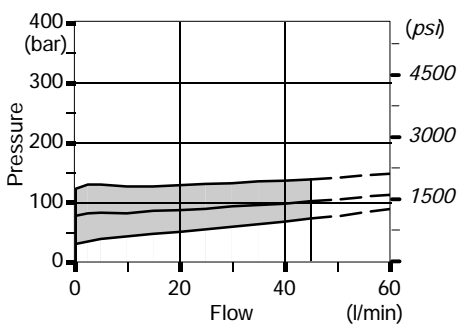

Spring nr. 3 (blue band)

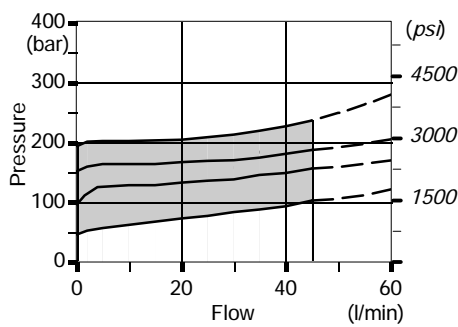

Spring nr. 4 (red band)

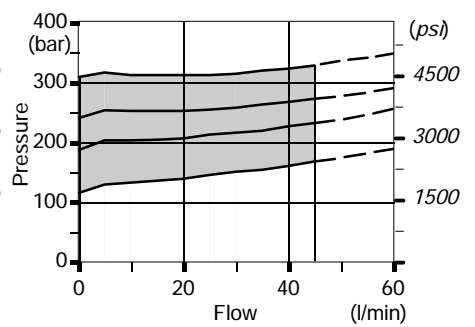

SV: relief valve blanking plug

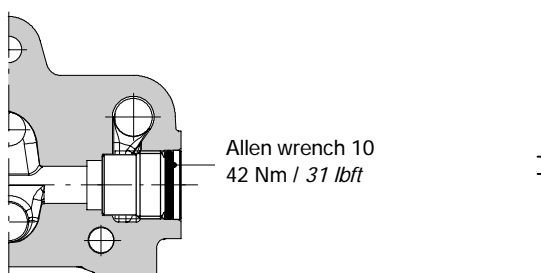

Time response

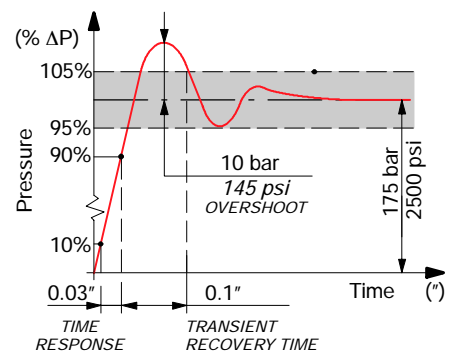

**Hydraulic pilot unloader valve, type L**

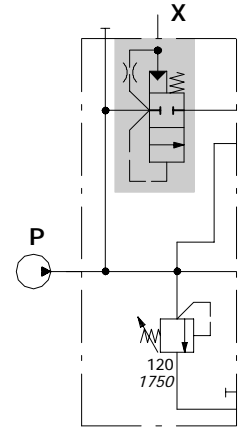
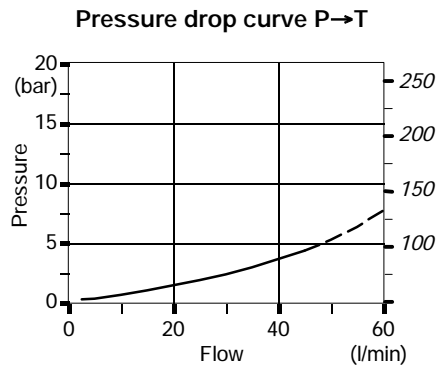
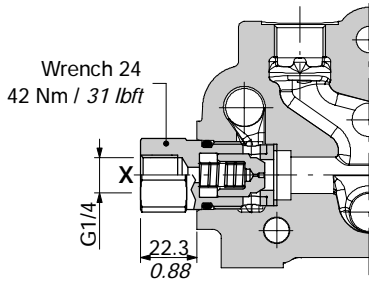

Description example:  
**AC(YG3-120)L**

**Operating features**

Internal leakage ..... : 10 cm<sup>3</sup>/min a 100 bar  
0.61 in<sup>3</sup>/min at 1450 psi

**Solenoid pilot unloader valve, type ELT**

With "push and twist" manual override with detent.

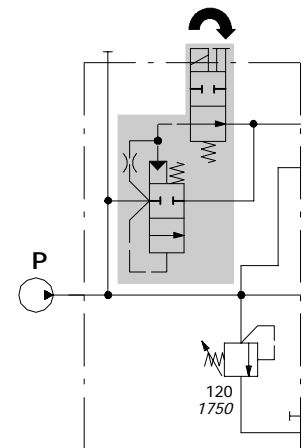
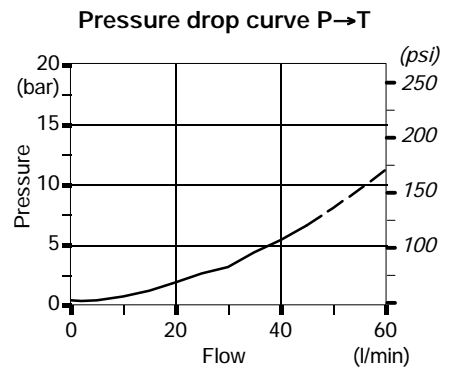
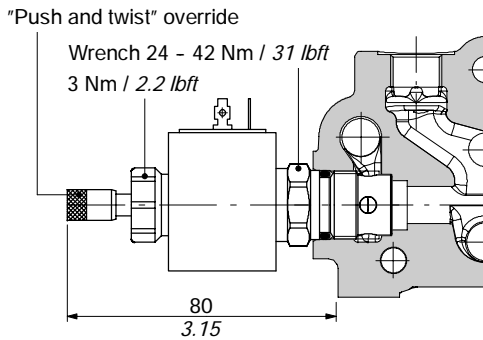

Description example:  
**AC(YG3-120)ELT-12VDC**

**Operating features**

VALVE

Internal leakage (in excited position): null

COIL

Depending on model: see features on next page



**R2 commutator configuration**

Manual rotary Backhoe clamp device.

Normally mounted on the lever side, into the main relief valve cavity, properly modified. Main relief valve available in the opposite side.

Available for left inlet (standard) and right inlet valve.

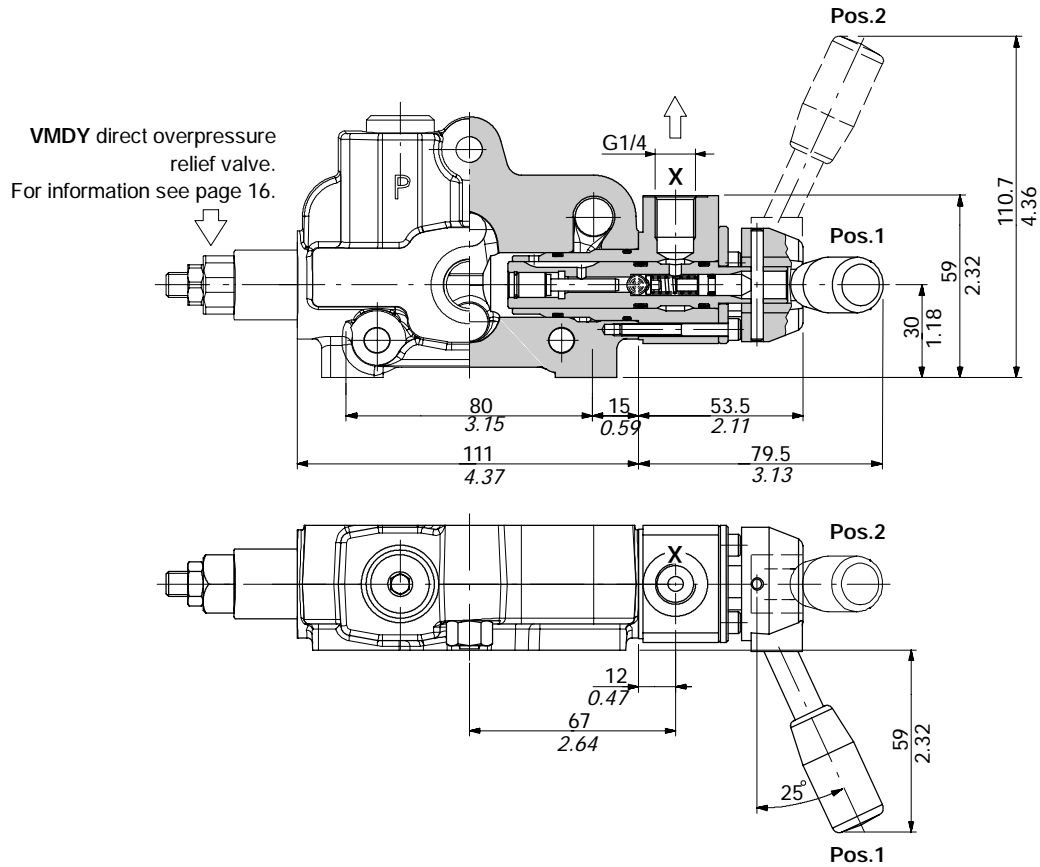

**Hydraulic circuit and ordering codes**

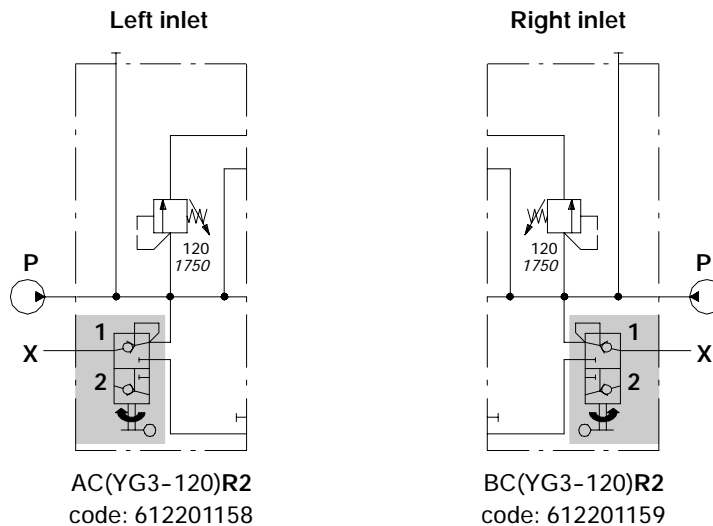

## S flow regulator configuration

Inlet cover with flow regulator on lever side: priority flow to working sections and exceeding flow to tank line.

Description example: **complete Inlet cover FE SD6 / AC (YG3-120) S N - BSP1/2**

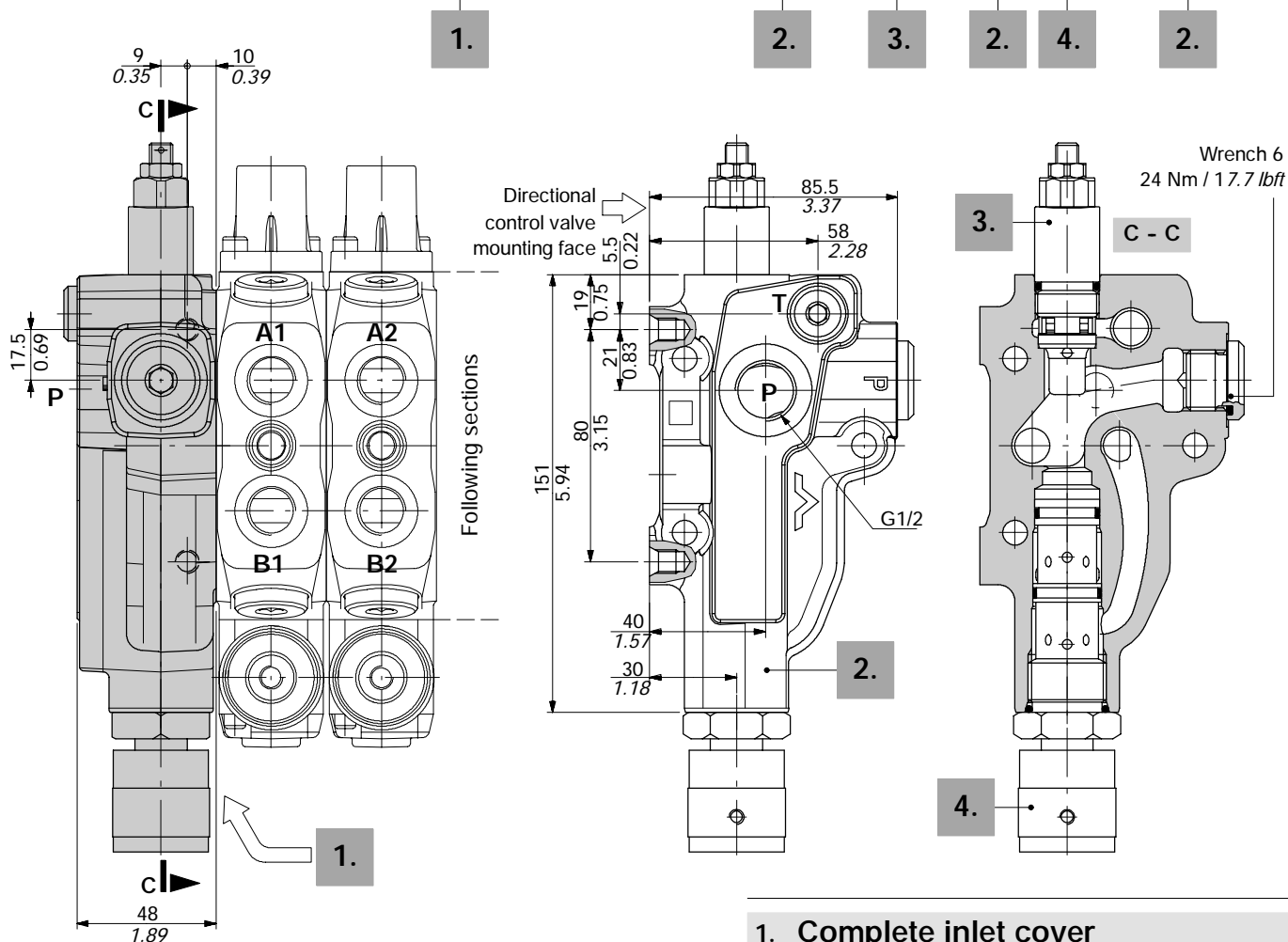

### 1. Complete inlet cover

TYPE: AC(YG3-120)SN-BSP1/2

CODE: 612202015

DESCRIPTION: Side inlet, VMDY overpressure relief valve and N handwheel flow control valve

NOTE: For other configurations please contact Sales Dept.

### 2. Inlet cover body

CODE: 3FIA106475+3XTAP719150+3XTAP727180

DESCRIPTION: Type AC-AD-BC-BD, port P = G1/2, prearranged for flow control

### 3. Inlet relief options

Direct overpressure relief valves type Y and J: see page 14

### 4. Flow control valve

TYPE	CODE	DESCRIPTION
M	2S0PP12002000	Handwheel control
N	2S1636030210	Handwheel control with detent
W2	2S0PP12002015	12VDC proportional solenoid valve

### Hydraulic circuit

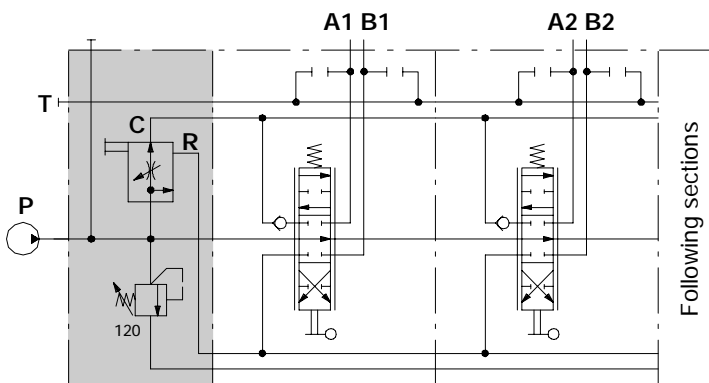

Description example:

SD6/4/AC(YG3-120)SN/18L/18L/...-BSP12(PT)38(AB)

**S flow regulator configuration**

**Handwheel operated**

**Continuous fine regulation**

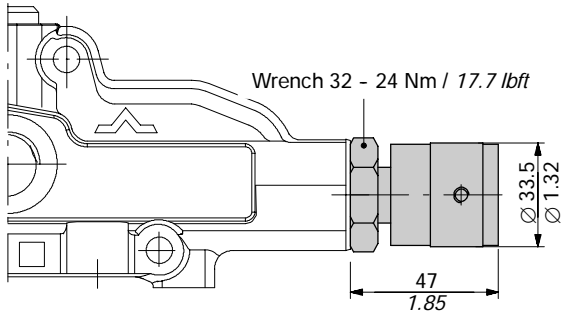

**One turn with detent**

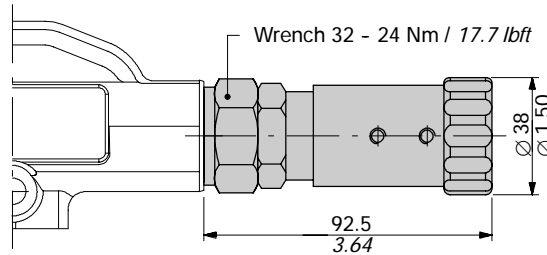

**Valve circuit**

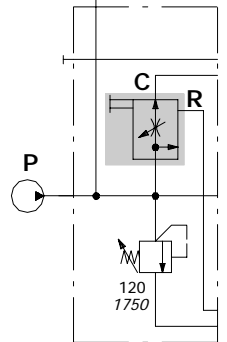

**With proportional solenoid control**

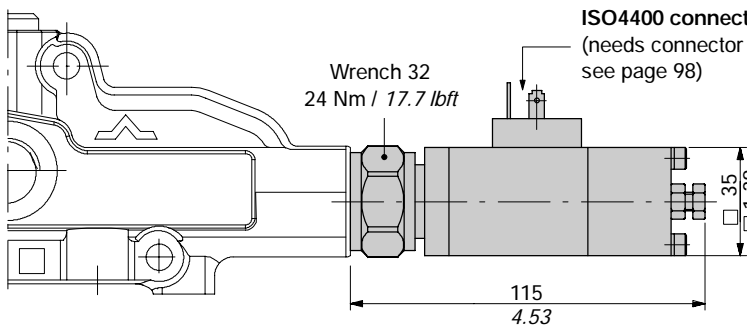

**ISO4400 connection**  
(needs connector type C02, see page 98)

**Solenoid operating features**

Nominal voltage . . . : 12 VDC  
Power rating . . . . . : 17,4 W  
Duty cycle . . . . . : 100%

**Valve circuit**

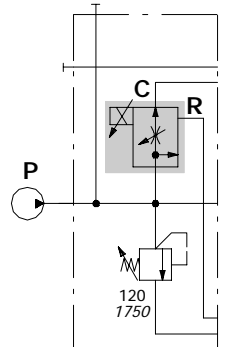

**Example of solenoid flow control valve connection**

It's show a configuration with push-button panel type UPA model UPA12/100/SC01B22: for information contact Sales Dept.

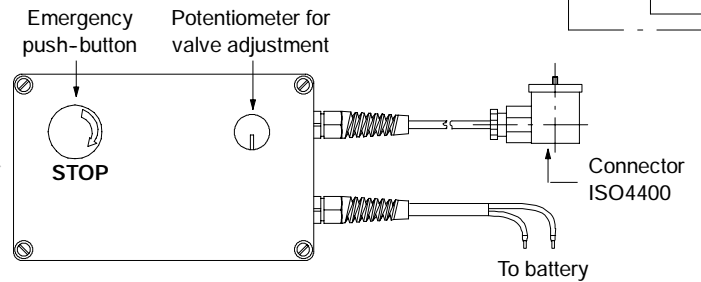

**Performance data**

**Pressure-flow diagram**

Q<sub>in</sub> = 45 l/min

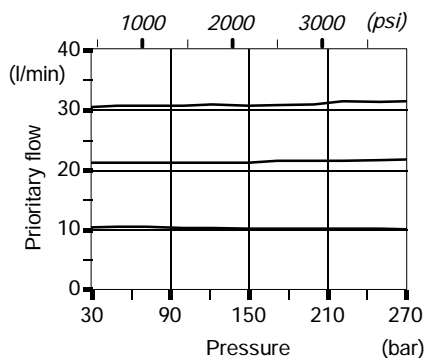

**Flow regulation diagram**

Q<sub>in</sub> = 45 l/min - P = 100 bar (1450 psi)

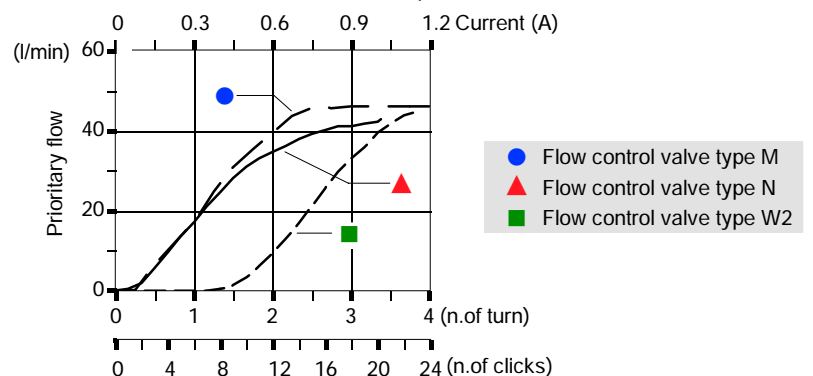

Ordering codes

Description example:

EL SD6 / P - 1 8 L . P 1 (G3 - 125) \*

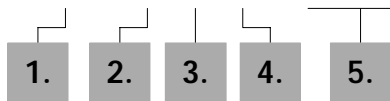

Port valves setting in bar

- 1 mounted on A port.
- 2 mounted on B port.
- 3 mounted on A and B port.

EL SD6 / P - 1M 8IM

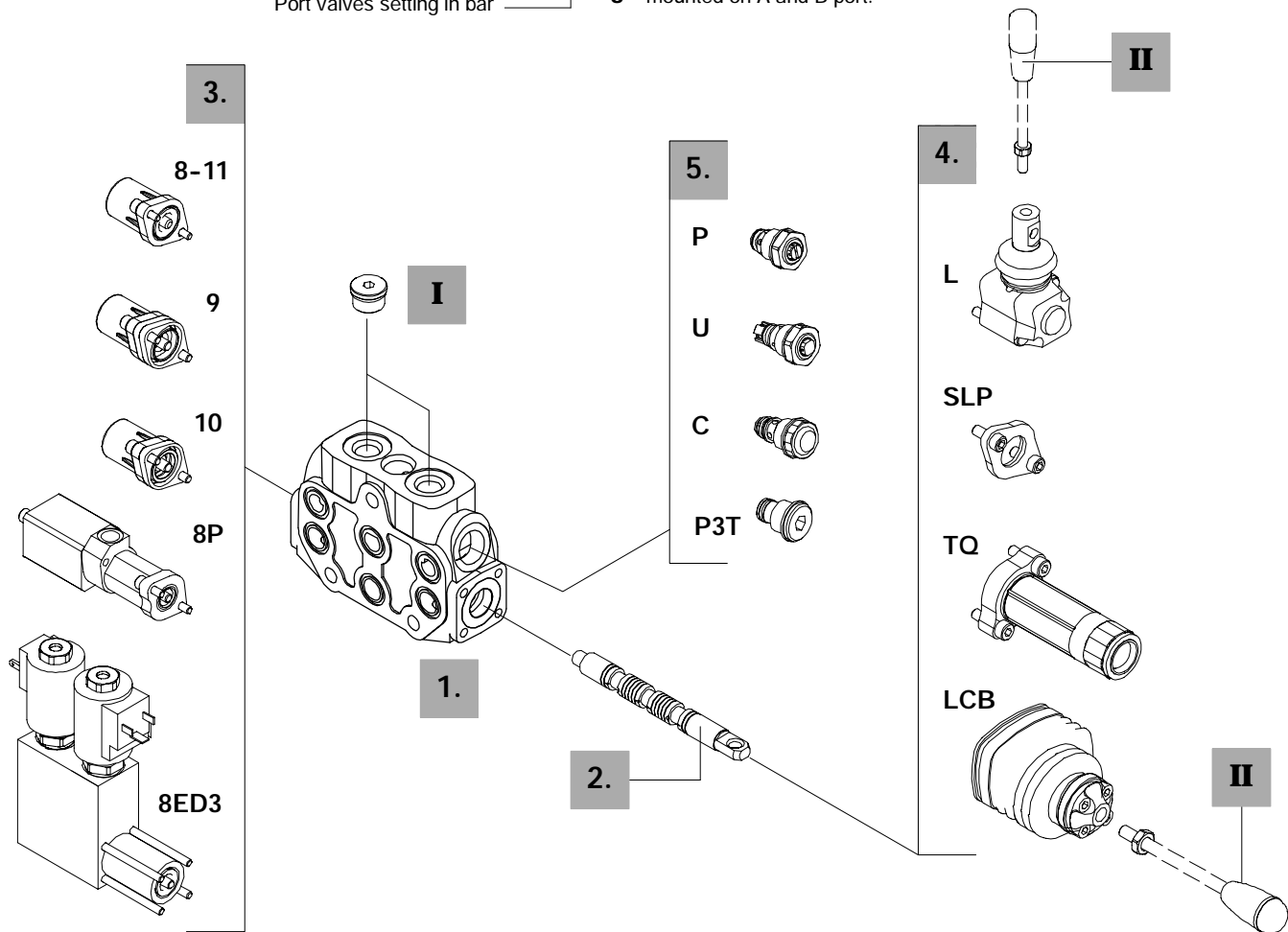

1. Working section kit \* page 24

TYPE	CODE	DESCRIPTION
P	5EL1063001	With paralle circuit
S	5EL2063001	With serie circuit
SP	5EL3063001	With serie-parallel (tandem) circuit

Include body, seals, rings and load check valve.

2. Spools page 25

TYPE	CODE	DESCRIPTION
1	3CU2210130	Double acting, 3 positions, with A and B closed in neutral position
1CS	3CU2210210	Double acting, 3 positions, with A and B closed in neutral position, sensitive type
1A	3CU2221130	Double acting, 3 positions, with A open to tank in neutral position

..... follow

2. Spools

TYPE	CODE	DESCRIPTION
1B	3CU2222130	Double acting, 3 positions, with B open to tank in neutral position
2	3CU2225130	Double acting, 3 positions, with A and B open to tank in neutral position
3	3CU2231130	Single acting on A, 3 positions, B plugged; requires G1/2 plug (see part I)
4	3CU2235130	Single acting on B, 3 positions, A plugged; requires G1/2 plug (see part I)

Special spools for particular positioner kits ..... page 29

5Y	3CU2242140	Double acting, 4 positions, float in position 3 with spool in
5BY	3CU2243130	Double acting, 4 positions, float in position 3 with spool out
8	3CU2262100	Double acting, 4 positions, regenerative in position 3

**3. "A" side spool positioners** *page 32*

TYPE	CODE	DESCRIPTION
7FT	5V07405000	With friction and neutral position sensor
8	5V08105000	With spring return in neutral position
8D	5V08105200	As type 8 and pin with M6 female thread for dual control
8D2	5V08105220	As type 8 and pin with $\varnothing 8$ mm / 0.31 in radial hole
8D3	5V08105230	As type 8 and pin with M8 female thread for dual control
8F2	5V08105101	As type 8 and adjustable flow limiter
19	5V19105000	2 positions, with spring return in neutral position from position 1
20	5V19105000	2 positions, with spring return in neutral position from position 2
9BZ	5V09202010	With detent in position 1 and spring return in neutral position
10BZ	5V10202010	With detent in position 2 and spring return in neutral position
11BZ	5V11202010	With detent in position 1 and 2, spring return in neutral position
8MG3(NO)	5V08105660	As type 8 and operation with microswitch in positions 1 and 2, contact normally open
8MG3(NC)	5V08105662	As previous, with contact normally closed
8RM2	5V08106590	As type 8 and 12VDC electromagnetic detent in position 2
	5V08106595	As previous, 24VDC
8MHE3(NC)	5V08106541	As type 8 and spool positioning ON/OFF electric signal circuit normally closed
8MHE3(NO)	5V08106540	As previous, with circuit normally open
8K	5V08705112	As type 8 and 12VDC solenoid lock device
	5V08705124	As previous 24 VDC
8P	5V08105701	ON/OFF pneumatic kit
8EPG3	5V08105738	ON/OFF 12 VDC electro-pneumatic kit
	5V08105743	ON/OFF 24 VDC electro-pneumatic kit
8ED3	5V08105350	ON/OFF 12 VDC electro-hydraulic kit
	5V08105351	ON/OFF 24 VDC electro-hydraulic kit
<u>Particular positioner kits for special spools</u> ..... <i>page 45</i>		
13NZ	5V13305010	4 positions with spring return in neutral position and detent in pos.3: <b>for spool 5Y</b>
13QN	5V13405020	4 positions with spring return in neutral position and detent in pos.3: <b>for spool 5BY</b>
13F	5V13506100	4 positions with spring return in neutral position: <b>for spool 8</b>
13QNMG3(NO)	5V13405660	As type 13QN with microswitch operation in positions 1 and 2: <b>for spool 5BY</b>

**4. "B" side options** *page 49*

TYPE	CODE	DESCRIPTION
L	5LEV105000	Standard lever box
LM10	5LEV205000	Lever box with M10 thread
LF1	5LEV105102	Lever box with adjustable flow limiter in pos.1
LFG5	5LEV105800	Cast iron lever box with adjustable flow limiter in positions 1 and 2
LB1	5LEV305100	Steel lever box with pivot placed down
LB3	5LEV305000	Steel lever box with pivot placed above
SL	-	Without lever box
SLP	5COP105000	Without lever box, with dust-proof plate
SLCZ	5COP205030	Without lever box, with endcap
..... follow		

**4. "B" side options**

TYPE	CODE	DESCRIPTION
LEB	5LEV605000	Safety lever box
LUP	5LEV805005	Safety lever box, horizontal type
TQ	5TEL105110	Flexible cable connection; for CD cables
LCB	5CLO206100	Joystick lever for 2 sections operation

**5. Port valves** *page 59*

TYPE	CODE	DESCRIPTION
<b>Assembled on section</b>		
P3T	XTAP524280	A and B ports valve blanking plugs
C	5KIT406100	Anti-cavitation
<u>Anti-shock valve</u>		
P(G2)	5KIT206112	From 50 to 125 bar / 725 to 1800 psi standard setting 63 bar / 900 psi
P(G3)	5KIT206113	From 100 to 200 bar / 1450 to 2900 psi standard setting 100 bar / 1450 psi
P(G4)	5KIT206114	From 160 to 315 bar / 2300 to 4600 psi standard setting 200 bar / 2900 psi
<u>Anti-shock and anti-cavitation valve</u>		
U(G2)	5KIT306112	From 50 to 125 bar / 725 to 1800 psi standard setting 63 bar / 900 psi
U(G3)	5KIT306113	From 100 to 250 bar / 1450 to 3600 psi standard setting 100 bar / 1800 psi
U(G4)	5KIT306114	From 160 to 315 bar / 2300 to 4600 psi standard setting 200 bar / 2900 psi
<i>Standard setting is referred to 10 l/min flow.</i>		

**Flange mounted type**

BPT	XTAP627300	BP and BPS valves blanking plug
-----	------------	---------------------------------

Direct type

BP1	612002000*	Block with valve on port A
BP2	612002000*	Block with valve on port B
BP3	612002100*	Block with valves on ports A and B
BP	XCAR605110	Single valve

With Pre-opening

BPS1	612003000*	Block with valve on port A
BPS2	612003000*	Block with valve on port B
BPS3	612003100*	Block with valves on ports A and B
BPS	XCAR605210	Single valve

**6. Complete controls** *page 54*

8IM\* proportional hydraulic and 8ES - 8ESN ON/OFF electric control kits.

**I "A" and "B" ports plug \***

TYPE	CODE	DESCRIPTION
G3/8	3XTAP722160	Plug for single acting spool

**II Optional hand levers**

TYPE	CODE	DESCRIPTION
AL01/M8x150	170011215	For L lever box, L = 150 mm / 5.91 in
AL01/M10x150	170012015	For LM10 and LFG5 lever boxes, L = 150 mm / 5.91 in
AL08/M12x200	170013120	For LCB joystick, L = 200 mm / 7.87 in

NOTE (\*) - Items are referred to **BSP** thread.

**Dimensional data and hydraulic circuit**

They are available with parallel or tandem circuit, with or without ports relief valves prearrangement.

**Parallel circuit**

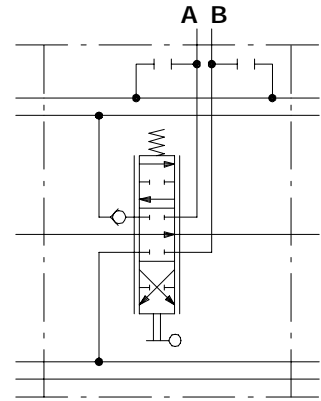
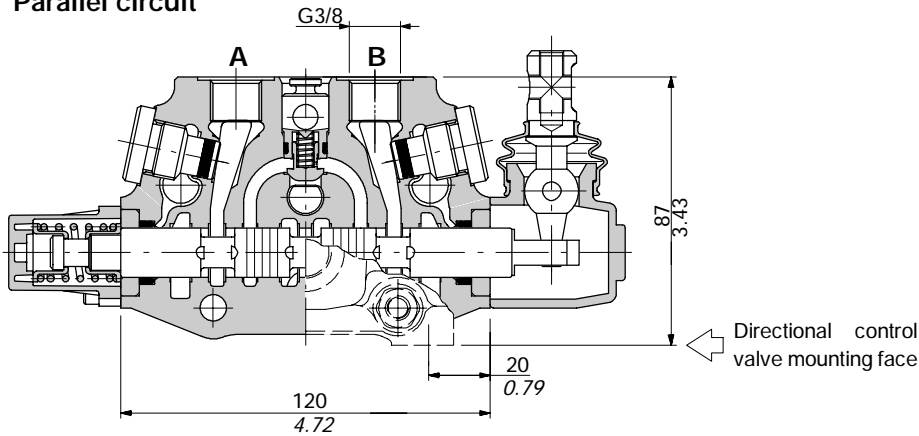

Description example:  
P-18L

**Series circuit**

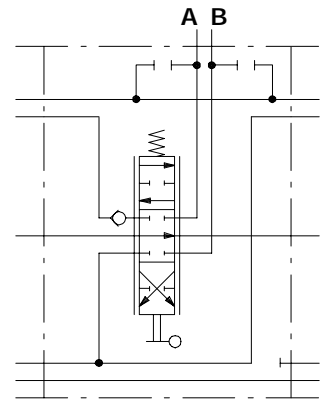
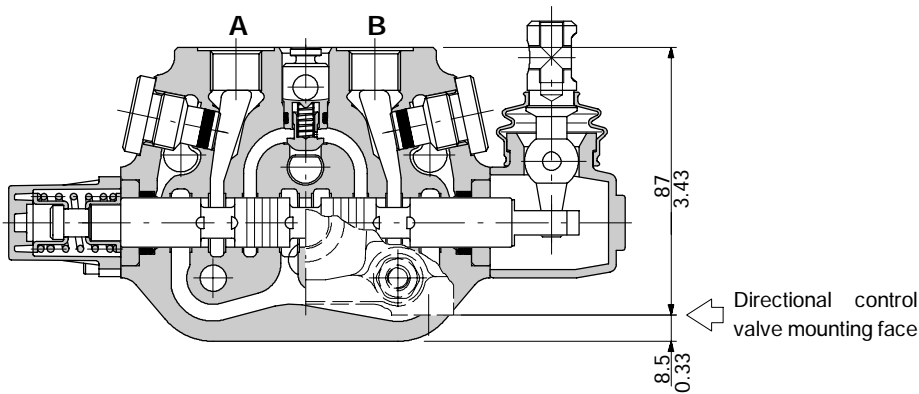

Description example  
S-18L

**Series-parallel (tandem) circuit**

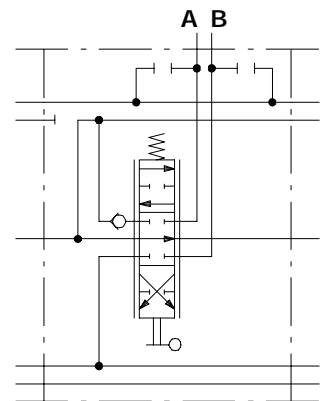
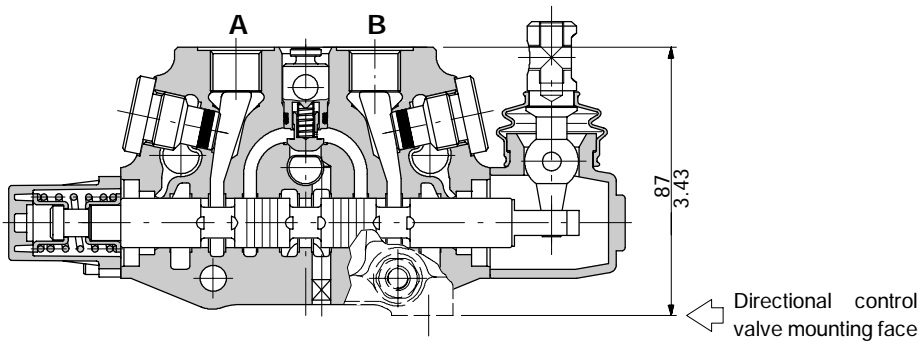

Description example  
SP-18L

Type 1

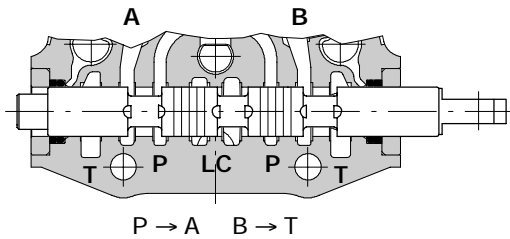

▶ stroke + 5.5 mm  
+ 0.22 in

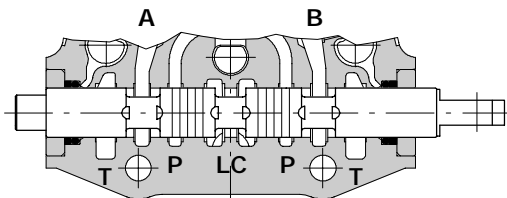
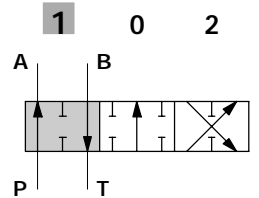

P-A-B-T closed, with flow through line (LC) open

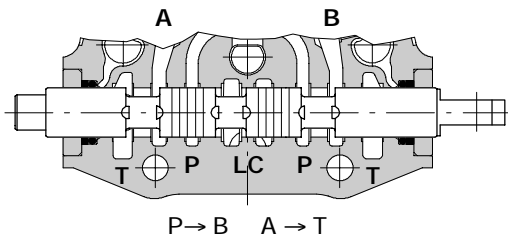
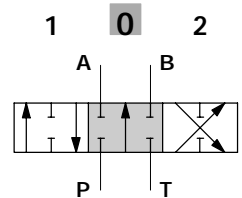

◀ stroke - 5.5 mm  
- 0.22 in

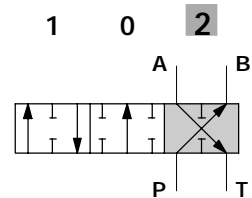

Performance data

Spool metering P → A(B)

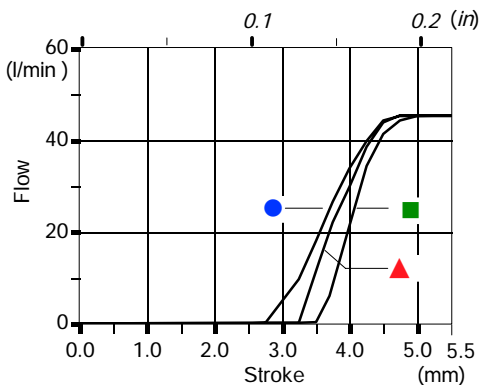

Q<sub>in</sub> = 45 l/min

- P<sub>(on ports)</sub> = 63bar / 900 psi
- ▲ P<sub>(on ports)</sub> = 100bar / 1450 psi
- P<sub>(on ports)</sub> = 250bar / 3600 psi

Spool metering A(B) → T

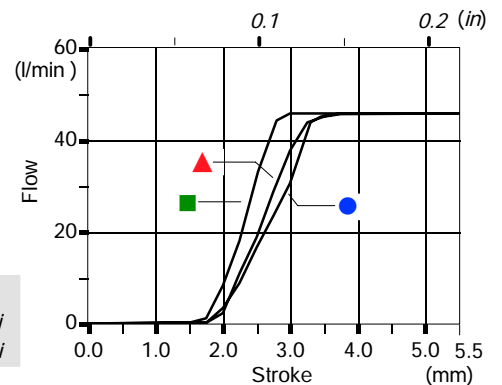

Spools

Type 1CS

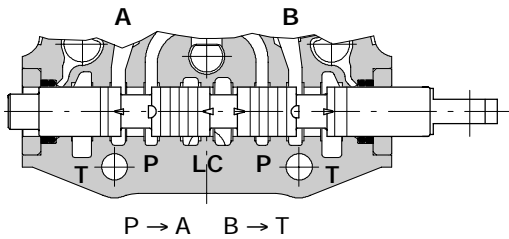

▶ stroke + 5.5 mm  
+ 0.22 in

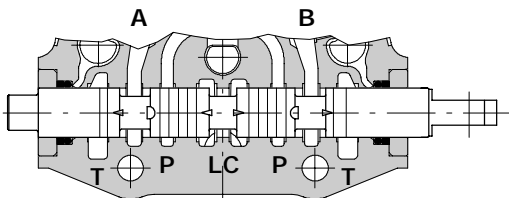
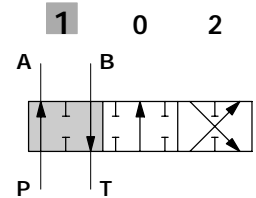

P-A-B-T closed, with flow through line (LC) open

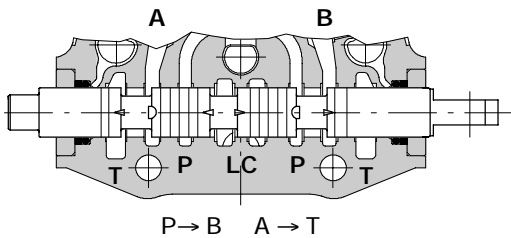
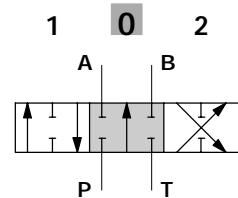

◀ stroke - 5.5 mm  
- 0.22 in

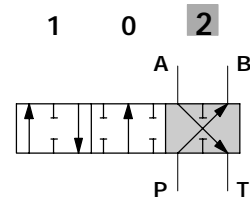

Performance data

Spool metering P→A(B)

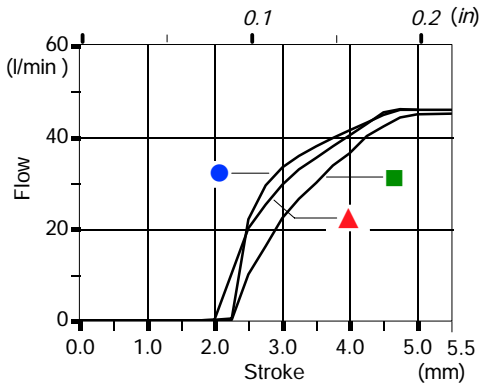

Q<sub>in</sub> = 45 l/min

- P(on ports) = 63bar / 900 psi
- ▲ P(on ports) = 100bar / 1450 psi
- P(on ports) = 250bar / 3600 psi

Spool metering A(B)→T

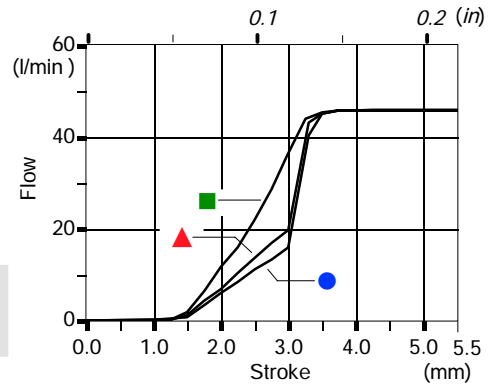

Type 1A

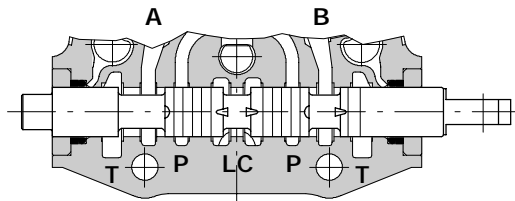

P-B closed, A→T, with flow through line (LC) open

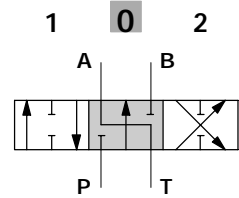

Type 1B

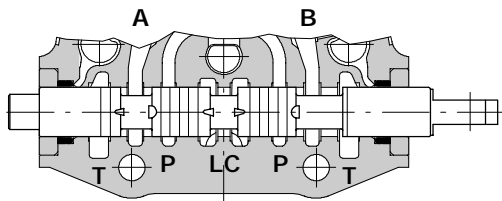

P-A closed, B→T, with flow through line (LC) open

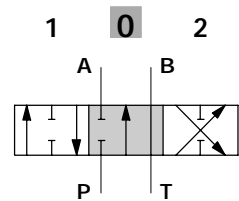

Type 2

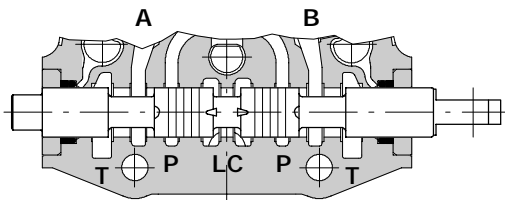

P closed, A-B→T, with flow through line (LC) open

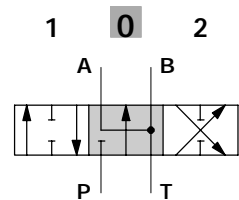

Spools

Type 3

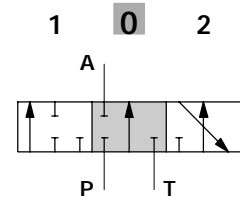
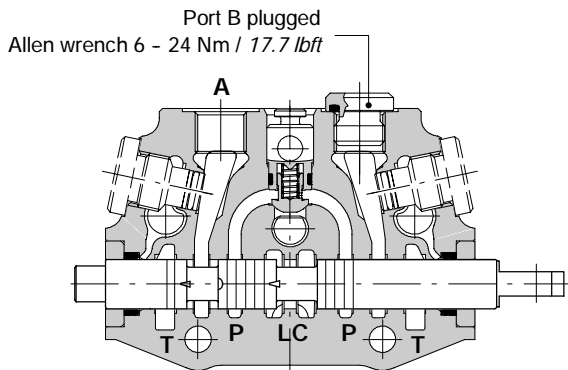

P-A-T closed, with flow through line (LC) open

Type 4

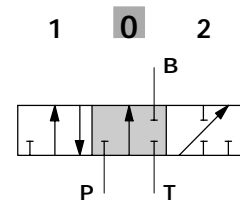
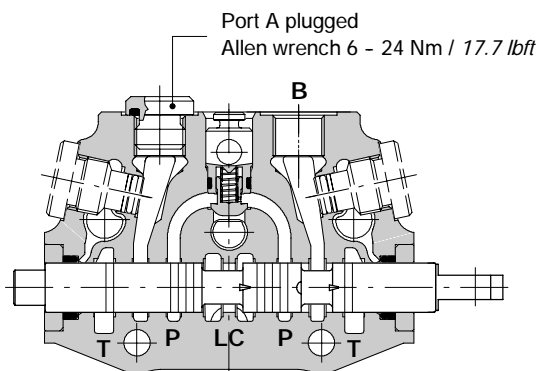

P-B-T closed, with flow through line (LC) open

**Type 5Y**

It needs special body with extra machining type **P-5Y** code **5EL1063203A**. It must be coupled only with spool positioner **13NZ** (see page 45).

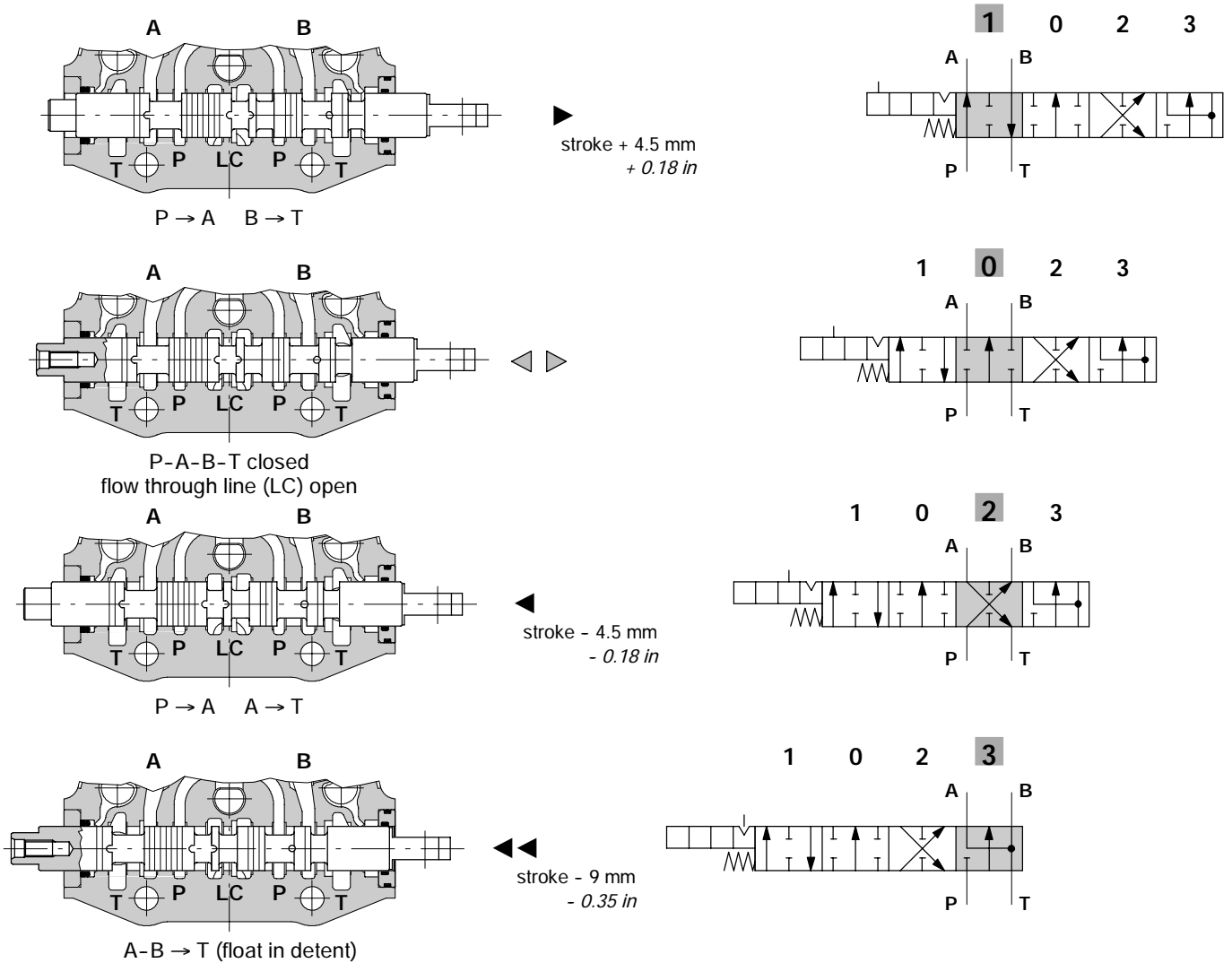

**Performance data**

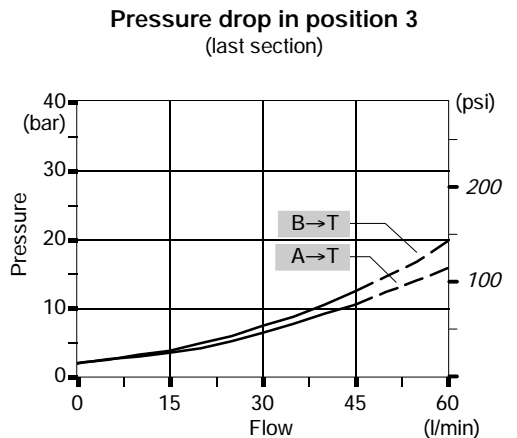
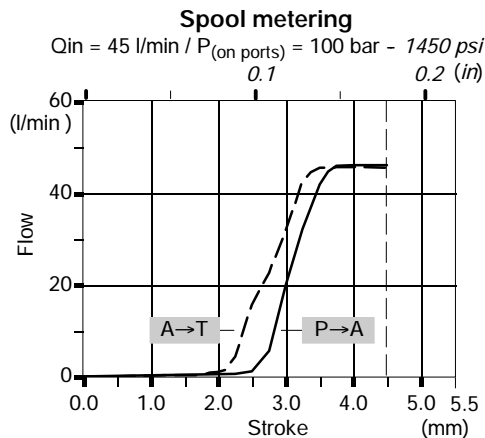

Spools

Type 5BY

It needs special body with extra machining type **P-5B** code **5EL1063205A**. It must be coupled only with spool positioner **13QN** (see page 45).

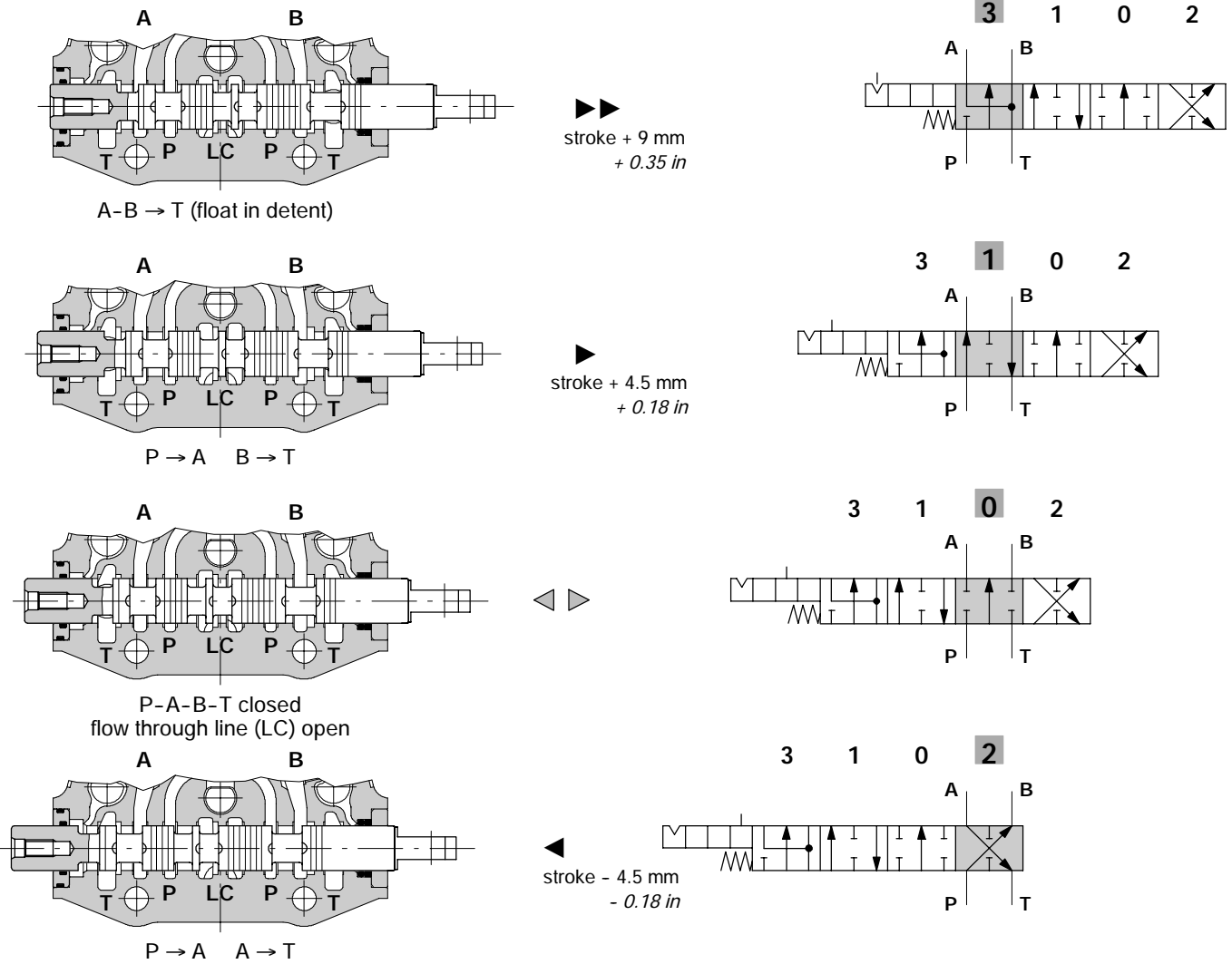

Performance data

Spool metering

$Q_{in} = 45 \text{ l/min} / P_{(on ports)} = 100 \text{ bar} - 1450 \text{ psi}$   
 0.1 0.2 (in)

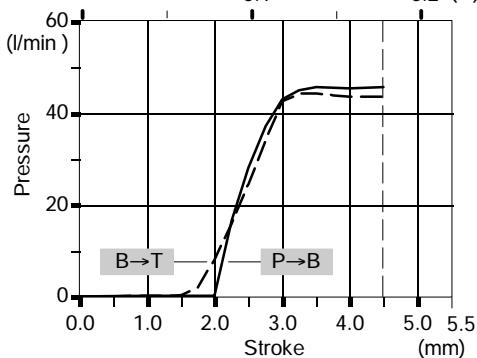

Pressure drop in position 3 (last section)

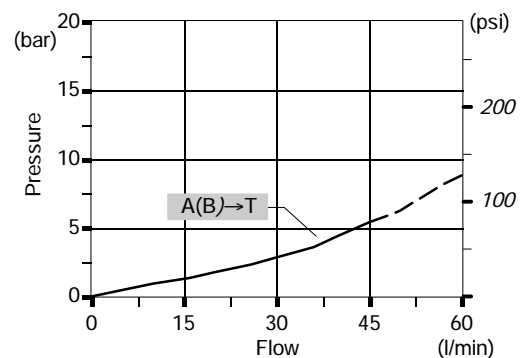

**Type 8**

It needs special body with extra machining type P-8 code 5EL1063500.

It must be coupled only with spool positioner 13F (see page 46).

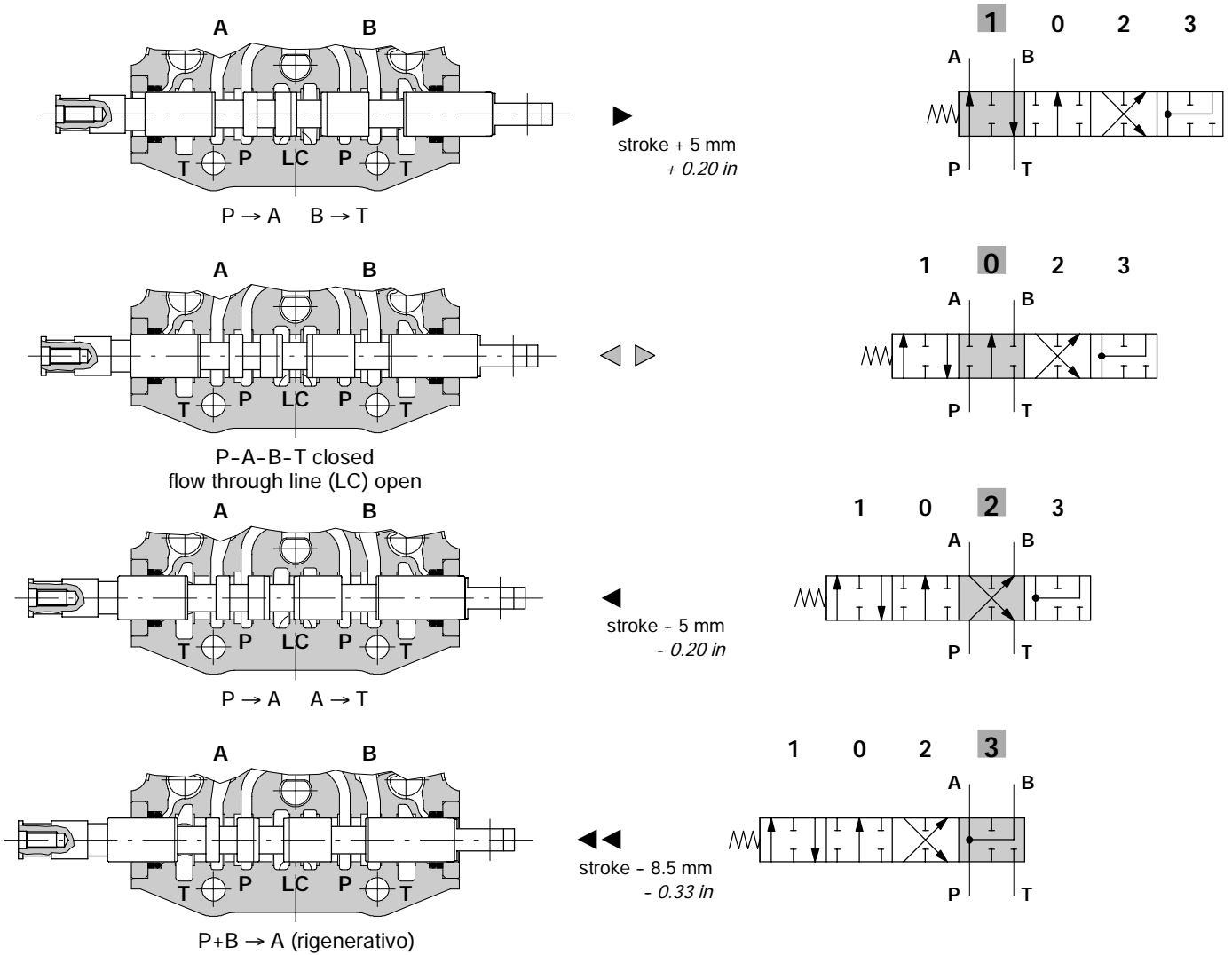

**Performance data**

**Spool metering**

$Q_{in} = 45 \text{ l/min} / P_{(on ports)} = 100 \text{ bar} - 1450 \text{ psi}$   
0.1 0.2 (in)

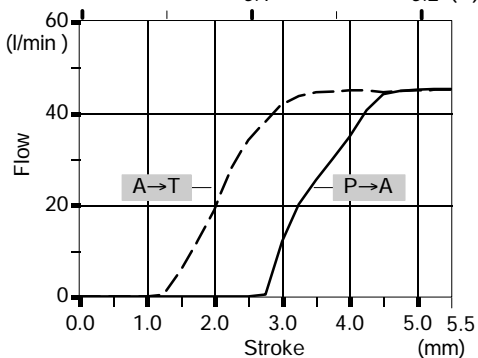

**Pressure drop in position 3 (last section)**

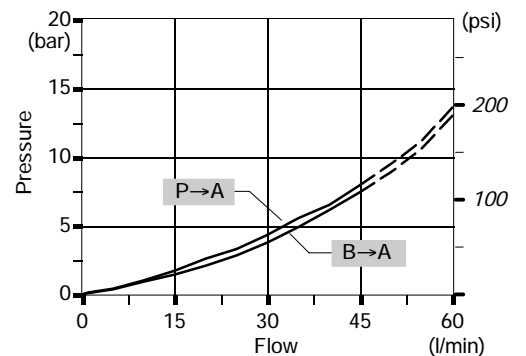

"A" side spool positioners

With spring return

8 kit

It's supplied with standard spring type D (see force-stroke diagram).

It's available with lighter spring type C (8MC code: 5V08205000) or heavier type E (8ME code: 5V08405000).

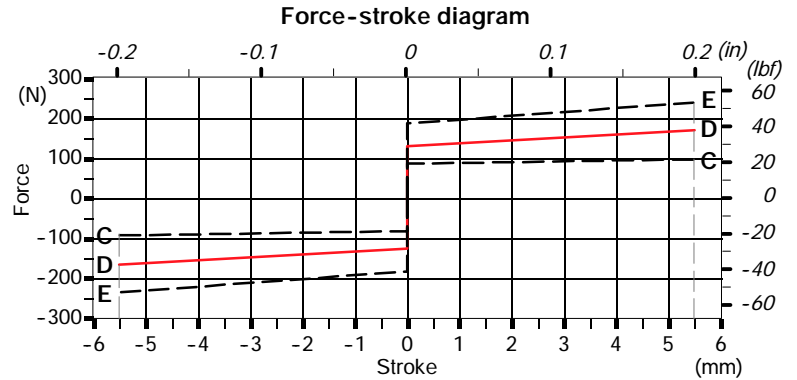
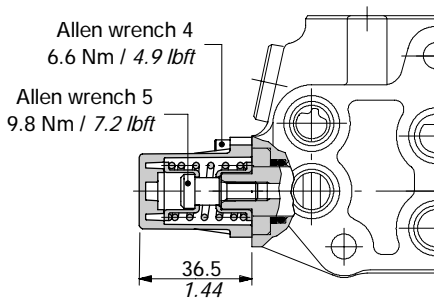
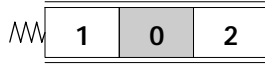

8D kit

It's available with lighter spring type C (8DMC code: 5V08205200); see previous diagram.

Spool end joint code XPER315400 is available on request in order to screw onto pin.

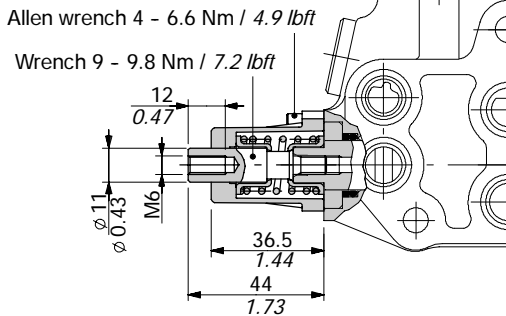
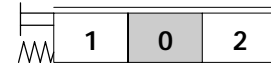

Spool end joint dimension

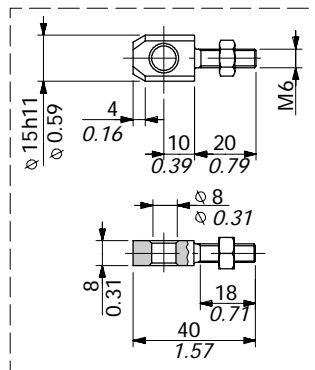

8D2 kit

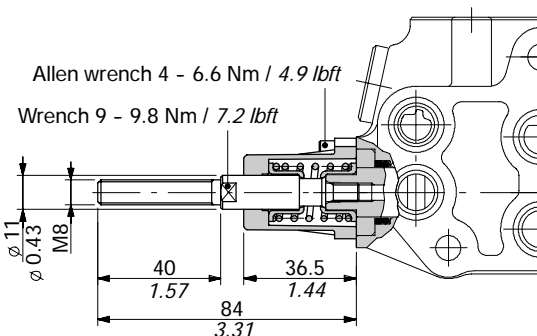
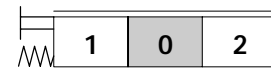

With spring return

8D3 kit

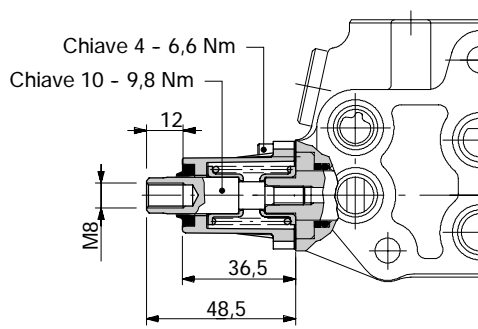

8F2 kit

With spool stroke adjustment in position 2 (P→B).

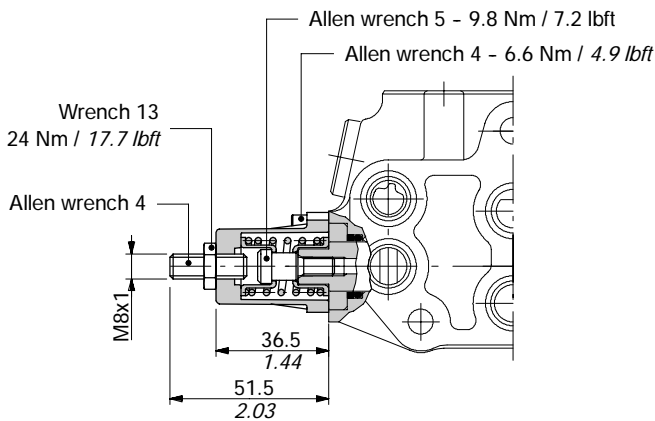
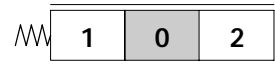

19 kit

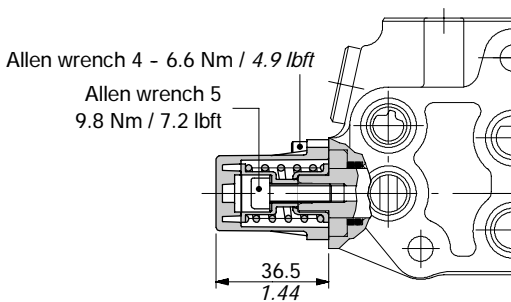
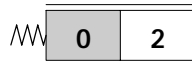

20 kit

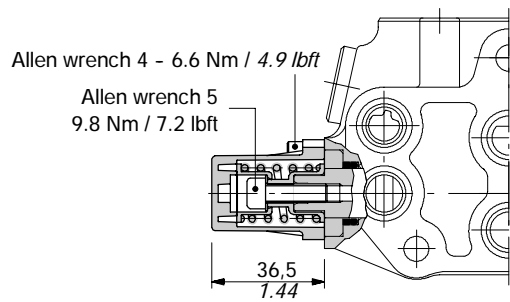
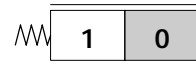

"A" side spool positioners

With detent and spring return to neutral from either directions

9BZ kit

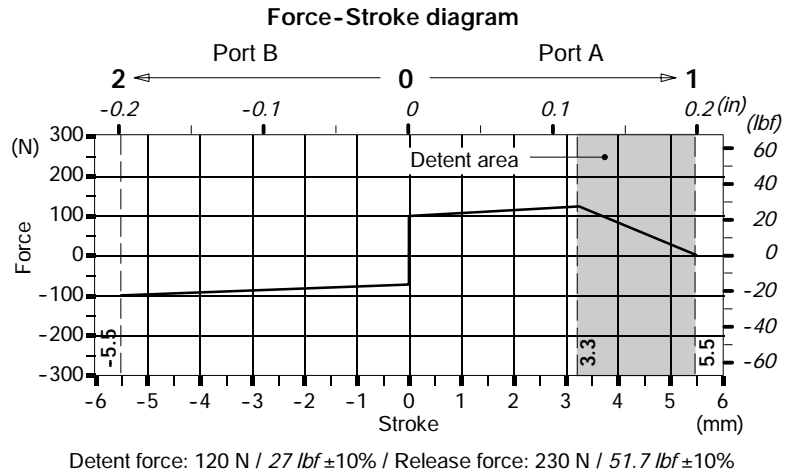
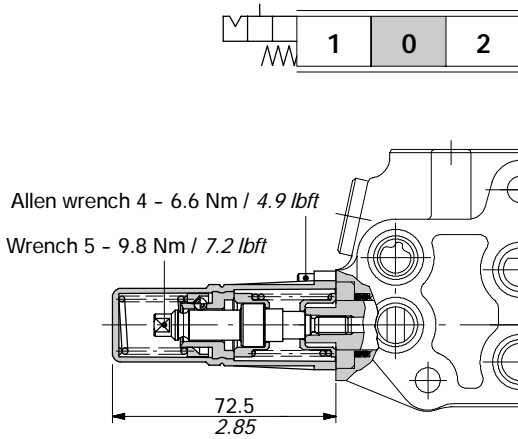

10BZ kit

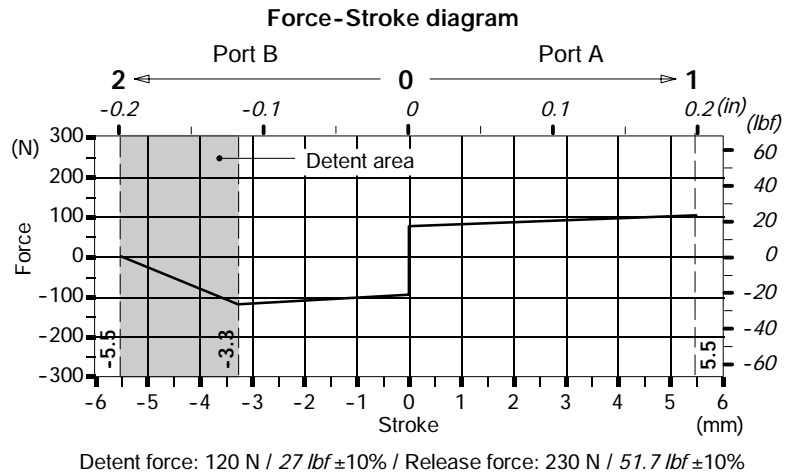
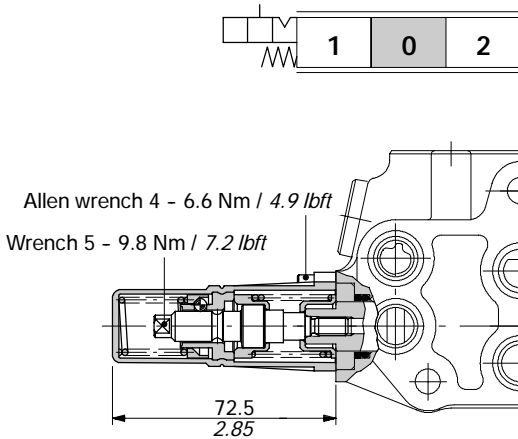

11BZ kit

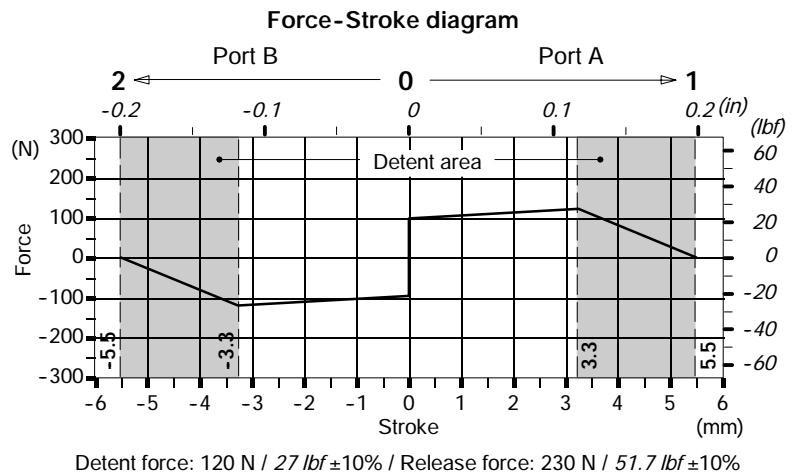
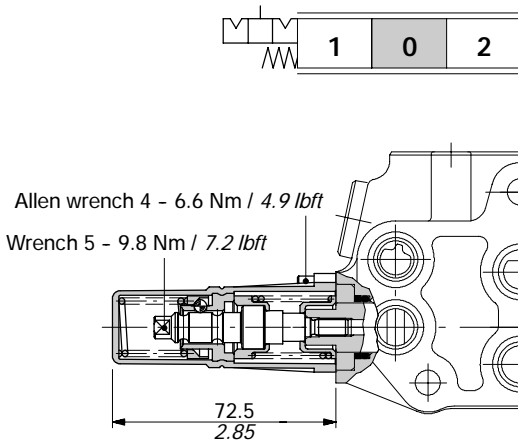

**"A" side spool positioners**

**8MHE3 kit: with spring return in neutral position and spool positioning ON/OFF signal**

This module supplies two different ON/OFF signals, related to the direction of the spool.

It has two separate contacts which can be normally open or normally closed.

It can be used with standard spools and working section (working section kit without ring on side "A")

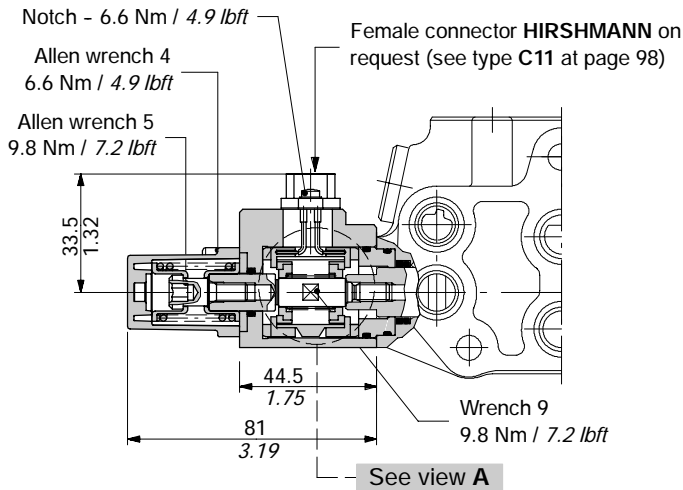

**Connector wiring**

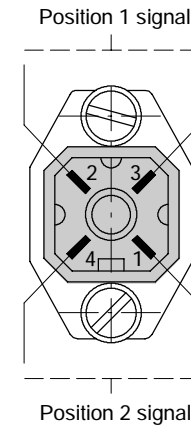

**Operating features**

- Power supply range : 12 / 24 VDC
- Max. output current : 500 mA
- Weather protection : IP65

**8MHE3(NC) kit**

Configuration with normally closed circuit

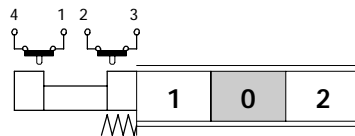

**View A**

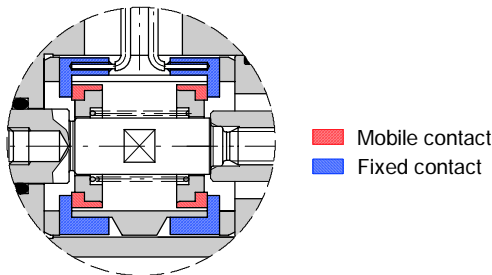

**Output signal with NC circuit**

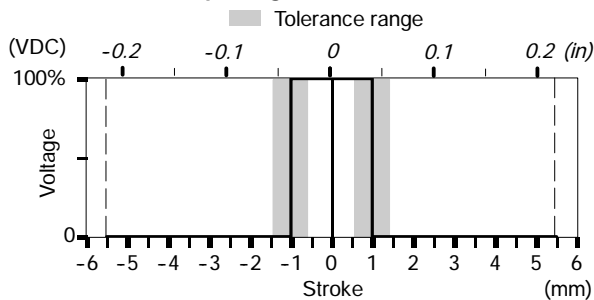

**8MHE3(NO) kit**

Configuration with normally open circuit

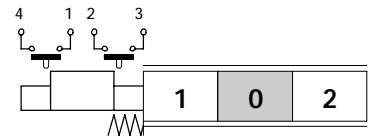

**View A**

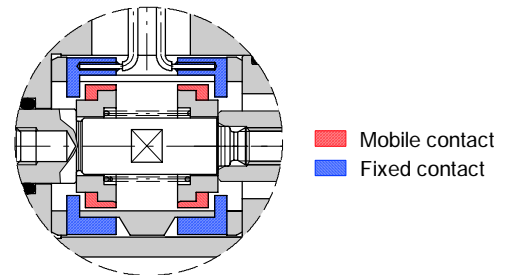

**Output signal with NO circuit**

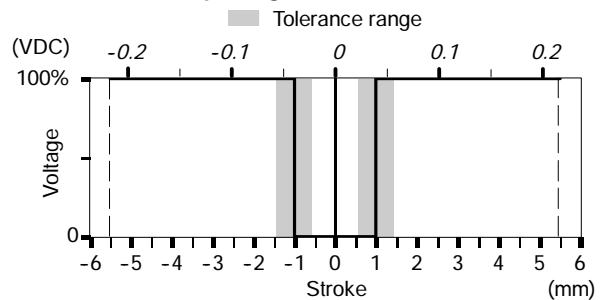

**"A" side spool positioners**

**With microswitch type 8MG3**

With spring return in neutral position and microswitch operated in both directions.

Also available **8MG1(NO)** configuration, code **5V08105670** (microswitch operated in position 1) and **8MG2(NO)** configuration, code **5V08105680** (microswitch operated in position 2); dimensions are the same of 8MG3 configuration.

These configurations are available also with normally closed (NC) contact.

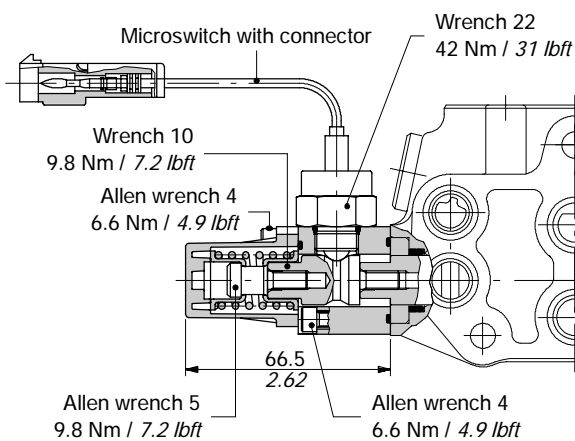

**Operating features**

**MICROSWITCH**

- Mechanical life . . . . . : 5x10<sup>5</sup> operations
- Electric life (resistive load) : 10<sup>5</sup> oper. - 7A / 13.5VDC
- : 5x10<sup>4</sup> oper. - 10A / 12VDC
- : 5x10<sup>4</sup> oper. - 3A / 28VDC

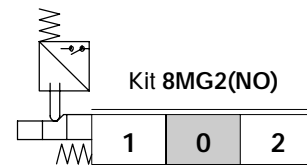
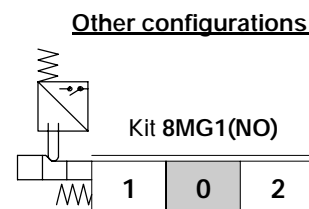
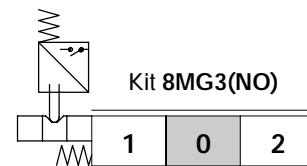

**COMPLETE CONTROLS CODES**

Contact	CONTROL TYPE			Need connector type
	8MG3	8MG2	8MG1	
NO	5V08105660	5V08105680	5V08105670	C07 see page 98
NC	5V08105662	5V08105682	5V08105672	C17

**"A" side spool positioners**

**With microswitch type 8MG3**

**More configurations and spare parts**

It's possible to obtain further configurations of complete control, using the MG kit, microswitches and 3 positions "A" side spool positioner, as following draw.

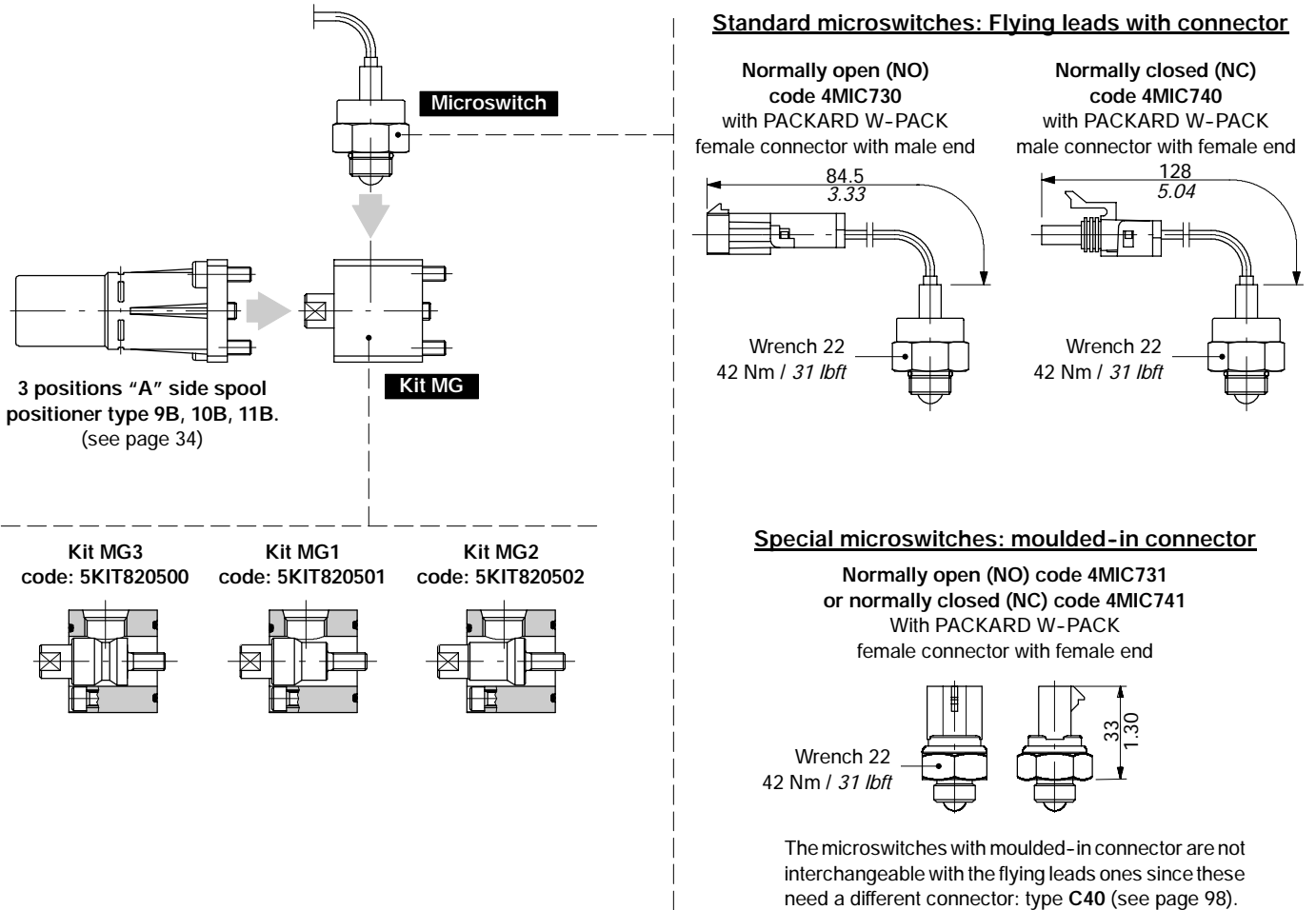

"A" side spool positioners

Solenoid lock device type 8K

With spring return and spool electromechanical lock in neutral position; when coil is feded the spool can be moved.

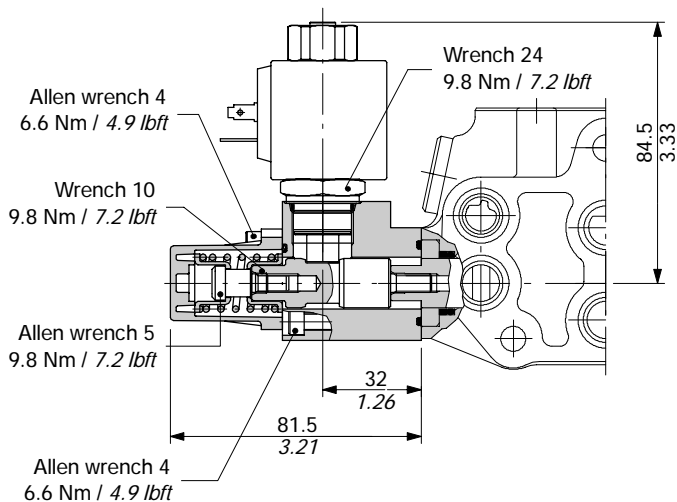
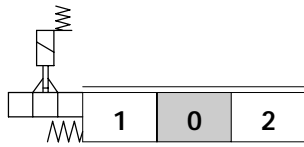

Operating features

ACTUATOR

Lock stroke ..... : 3.5 mm / 0.14 in

COIL

Depending on model: see following features

Coil with ISO4400 connector

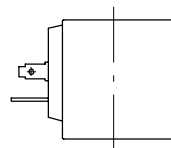

Nom. voltage tolerance ..... : ±10%  
 Power rating ..... : 18 W  
 Nominal current ..... : 1.58 A - 12 VDC  
 : 0.81 A - 24VDC  
 Coil insulation ..... : Class F  
 Weather protection ..... : IP65  
 Duty cycle ..... : 100%

Coil with Deutsch DT connector

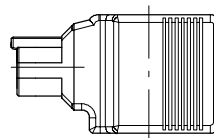

Nom. voltage tolerance ..... : ±10%  
 Power rating ..... : 22 W  
 Nominal current ..... : 1.9 A - 12 VDC  
 : 0.95 A - 24VDC  
 Coil insulation ..... : Class H  
 Weather protection ..... : IP65  
 Duty cycle ..... : 100%

Coil with Packard M-Pack connector

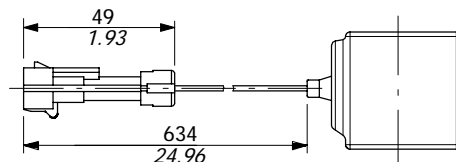

Nom. voltage tolerance ..... : ±10%  
 Power rating ..... : 18 W  
 Nominal current ..... : 1.58 A - 12 VDC  
 : 0.81 A - 24VDC  
 Coil insulation ..... : Class F  
 Weather protection ..... : IP65  
 Duty cycle ..... : 100%

COMPLETE CONTROL CODES

Voltage	CONNECTION TYPE		
	ISO4400	Deutsch DT	Packard M-Pack
	CONTROL TYPE		
	8K	8K4	8K6
12 VDC	5V08706112	5V08706412	5V08706612
24 VDC	5V08706124	5V08706424	5V08706624
Need connector type (see page 98)	C02	C19	C20

"A" side spool positioners

Solenoid lock device type 8K

More configurations and spare parts

It's possible to obtain further configurations of complete control, using the K kit, coils and 3 positions "A" side spool positioner, as following draw: for information contact Sales Department.

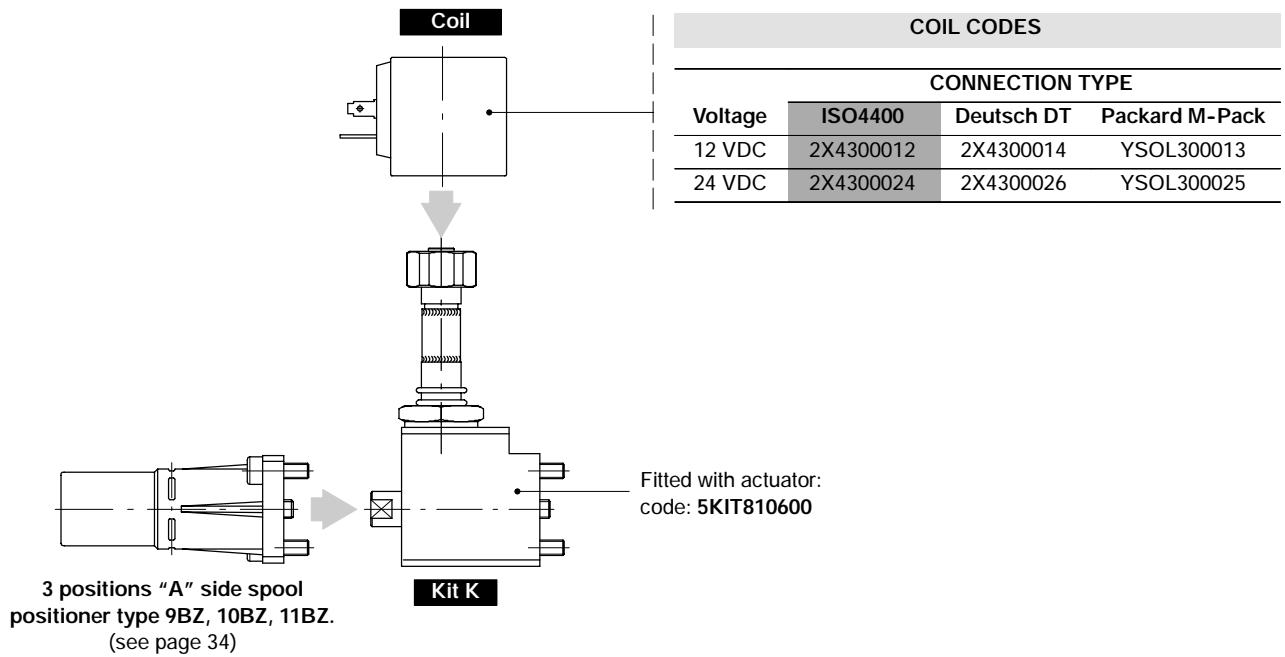

8P ON/OFF pneumatic control

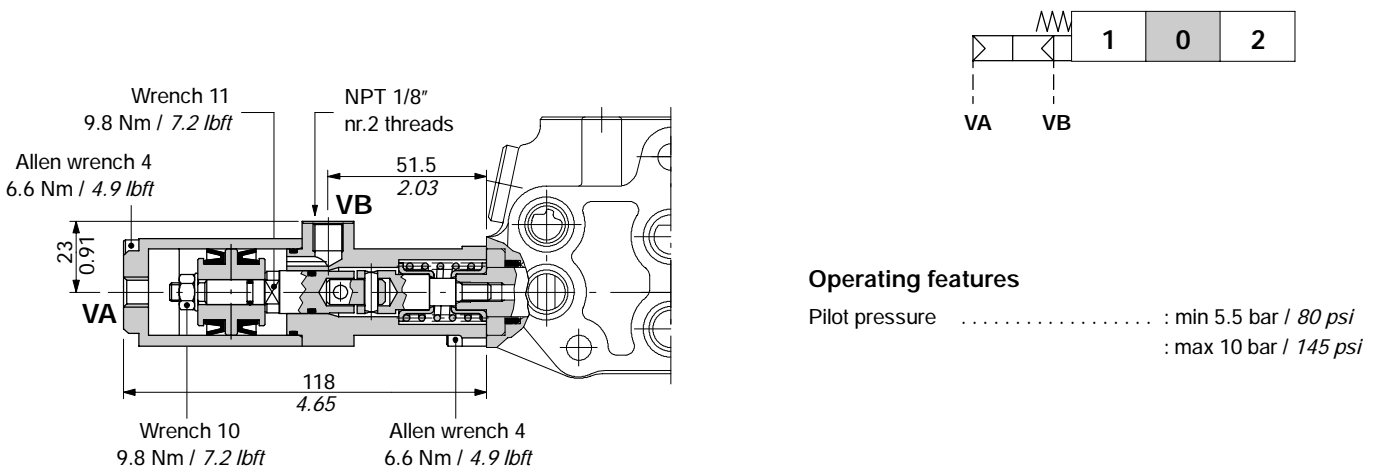

**"A" side spool positioners**

**Electromagnetic detent type 8RM2**

With electromagnetic detent in position 2 and spring return to neutral position.  
Needs special working section body kit without washer on positioner side.

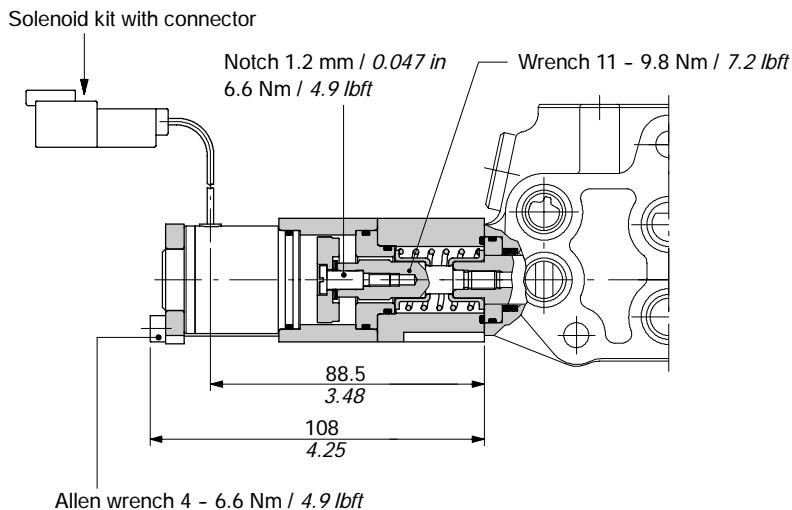
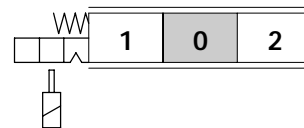

**Operating features**

**COIL**

Nominal voltage	: 12 / 24 VDC ± 10%
Power rating	: 5.5 W
Resistance (20 °C)	: 26.2 / 105 Ohm
Min. release force	: 100 N - 22.5 lbf
Duty cycle	: 100%

**COMPLETE CONTROL CODES**

	CONNECTION TYPE		
	Deutsch DT	AMP	Packard M-Pack
Voltage	CONTROL TYPE		
	8RM2	8RM2A(200)	8RM2M(350)
12 VDC	5V08106590	5V08106591	5V08106593
24 VDC	5V08106595	5V08106596	5V08106598
Need connector type (see page 98)	C19	C21	C20

**COIL CODES**

Voltage	CONNECTION TYPE		
	Deutsch DT	AMP	Packard M-Pack
12 VDC	YSOL532455	YSOL532452	YSOL532451
24 VDC	YSOL532456	YSOL532458	YSOL532457

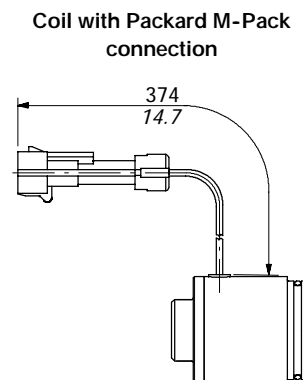
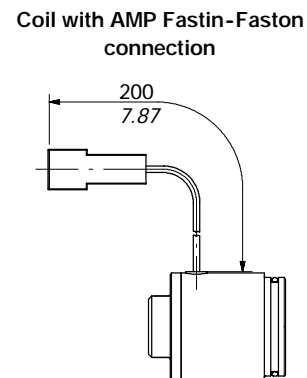
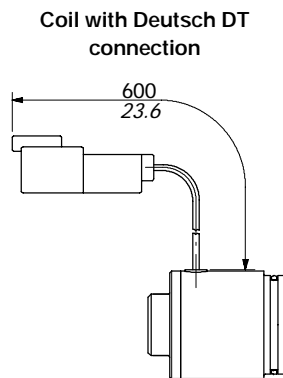

8EP3 ON/OFF electro-pneumatic control

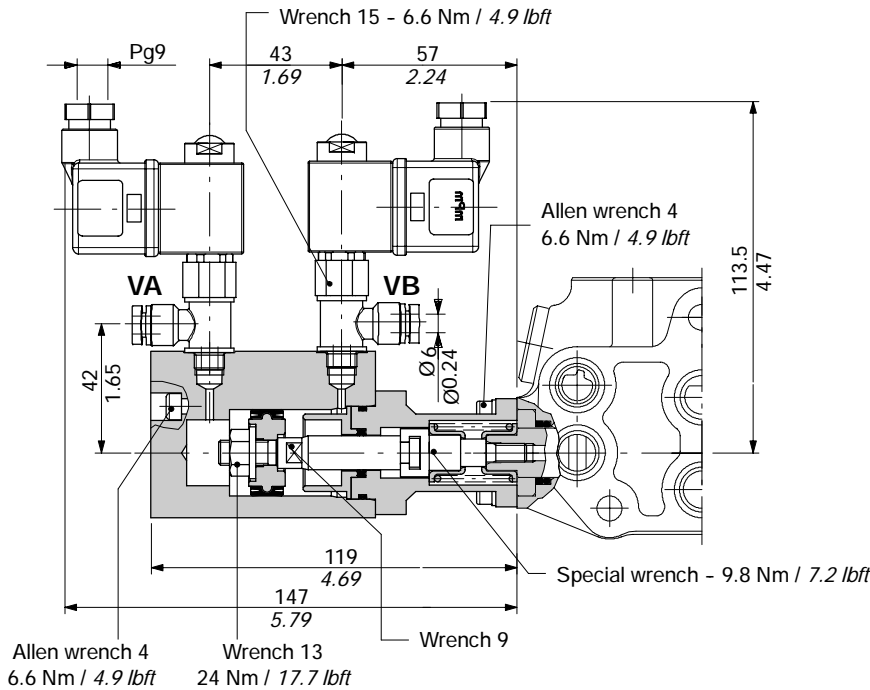

Scheme

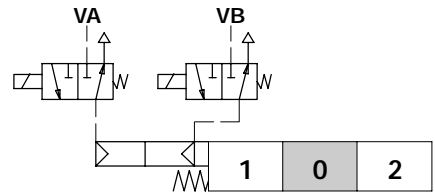

Scheme ISO 1219

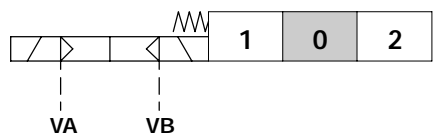

COMPLETE CONTROL CODES

	CONNECTION TYPE	
	ISO6952	Flying leads
Voltage	CONTROL TYPE	
	8EPG3	8EPG35
12 VDC	5V08105738	5V08105736
24 VDC	5V08105743	5V08105741
Need connector type (see page 98)	C01 (included)	/

COIL CODES

Voltage	CONNECTION TYPE	
	ISO6952	Flying leads *
12 VDC	2XB1010121100	2XB1010120000
24 VDC	2XB1010241100	2XB1010240000

\* Several type of connectors can be wired on request: contact Sales Department.

Operating features

CONTROL

Pilot pressure ..... : 6 bar / 87 psi  
: (max.15 bar / 218 psi)

COIL

Nominal voltage tolerance ..... : ±10%  
Power rating ..... : 8 W  
Nominal current ..... : 0.67 A - 12 VDC  
: 0.33 A - 24VDC  
Coil insulation ..... : Class H  
Weather protection ..... : IP65  
Duty cycle ..... : 100%

Coil with ISO6952 connector

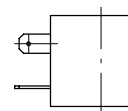

Coil with flying leads

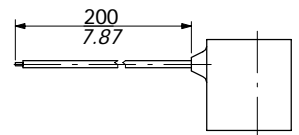

**"A" side spool positioner**

**8ED3 ON/OFF electro-hydraulic control**

ON/OFF electro-hydraulic control with external pilot and drain.

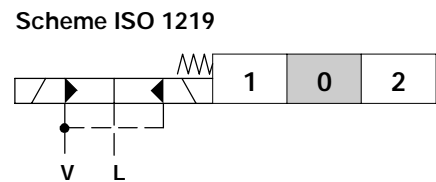
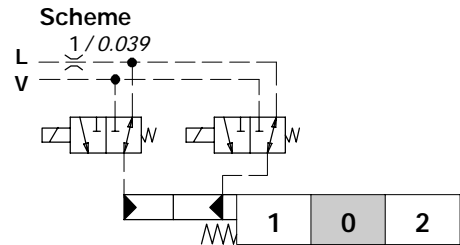
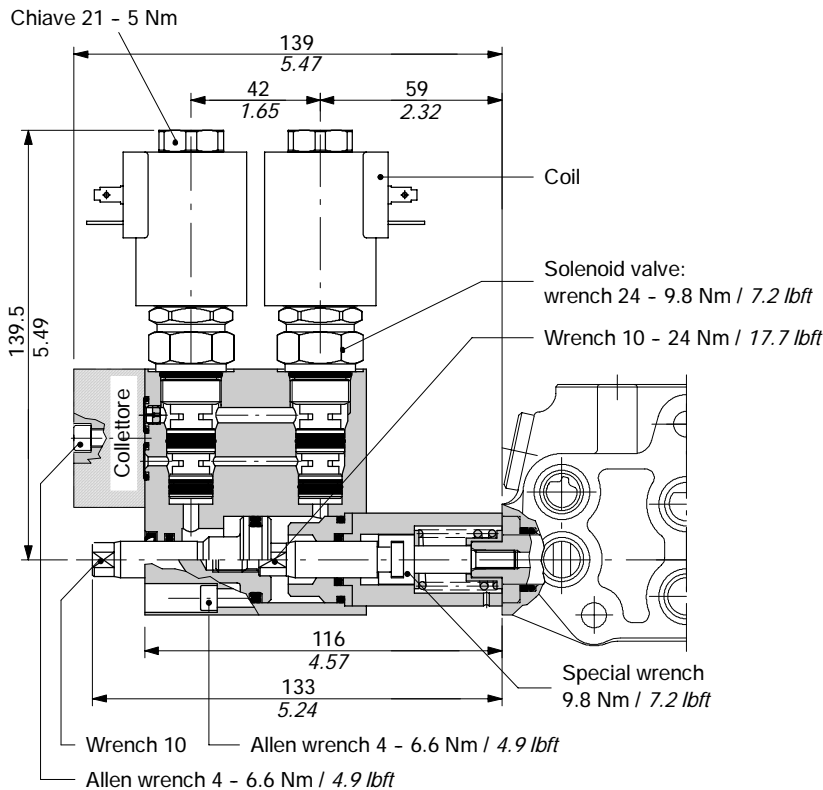

**Operating features**

**CONTROL**

Pilot pressure : min. 10 bar / 145 psi  
 : max. 50 bar / 725 psi  
 Max backpressure on drain L : 25 bar / 360 psi

**COIL**

Nominal voltage tolerance : ±10%  
 Power rating : 21 W  
 Nominal current : 1.75 A - 12 VDC / 0.87 A - 24VDC  
 Coil insulation : Class F  
 Weather protection : depending on coil connector  
 Duty cycle : 100%

**COMPLETE CONTROL CODES**

	CONNECTION TYPE			
	ISO4400	AMP JPT		Deutsch DT
		without diode	with diode	
CONTROL TYPE				
Voltage	8ED3	8ED32	8ED32D	8ED34
12 VDC	5V08105350	5V08105250	5V08105280	5V08105450
24 VDC	5V08105351	5V08105251	5V08105281	5V08105451
Need connector type (see page 98)	C02	C08	C08	C19

8ED3 ON/OFF electro-hydraulic control

COIL CODES

Voltage	CONNECTION TYPE			
	ISO4400	AMP JPT		Deutsch DT
		without diode	with diode	
12 VDC	2XB1400121100	2XB1400121200	2XB1400121210	2XB1400120400
24 VDC	2XB1400241100	2XB1400241200	2XB1400241210	2XB1400240400

Coil with ISO4400 connection  
(weather protection: IP65)

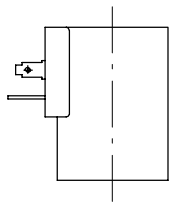

Coil with AMP JPT connection  
(weather protection: IP65)

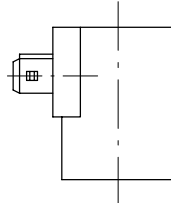

Coil with Deutsch DT connection  
(weather protection: IP67)

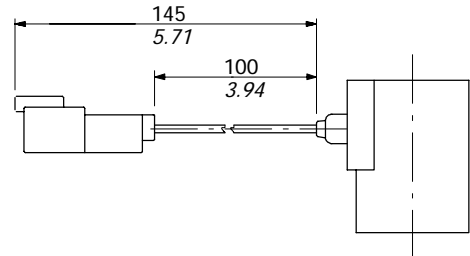

Collector kit for external pilot and drain

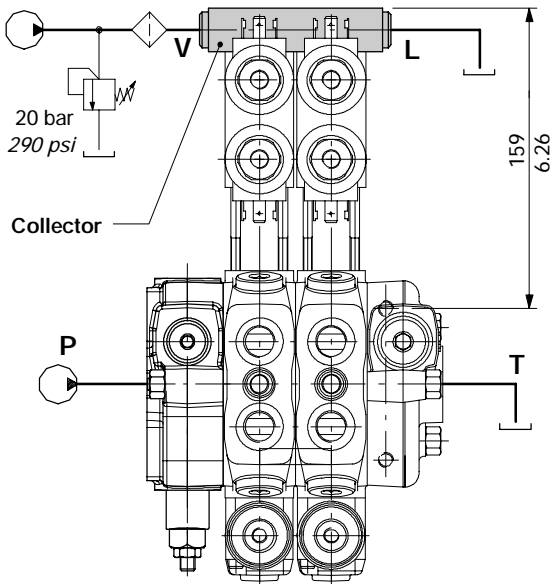

Description example:  
SD6/2/AC(YG3-120)/18ED3L/18ED3L/RC-KE2S0-24VDC

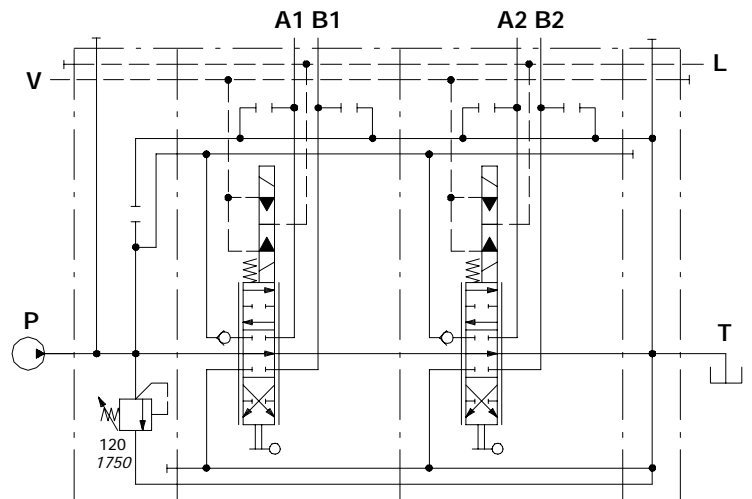

COLLECTOR KIT CODES

Type	Code *	Description
KE1S0	5KE1S00030	Kit one section
KE2S0	5KE2S01230	Kit for 2 sections
KE3S0	5KE3S01230	Kit for 3 sections
KE4S0	5KE4S01230	Kit for 4 sections
KE5S0	5KE5S01230	Kit for 5 sections
KE6S0	5KE6S01230	Kit for 6 sections
KE7S0	5KE7S01230	Kit for 7 sections

(\*) codes are referred to BSP thread

**"A" side spool positioners**

**8ED3 ON/OFF electro-hydraulic control**

**Kit collettore con linee di pilotaggio e drenaggio**

The kit include collector, VRP pressure reducing valve and pipes.

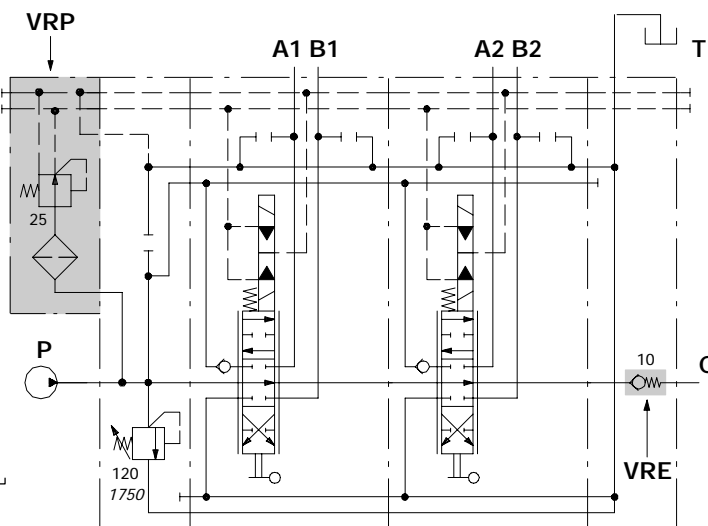
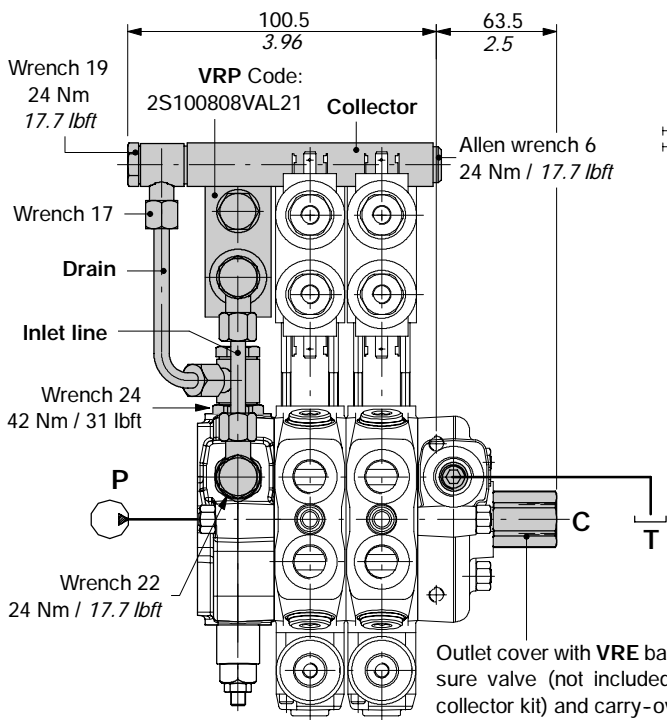

Outlet cover with VRE backpressure valve (not included in the collector kit) and carry-over.

Description example:

SD6/2/AC(YG3-120)/18ED3L/18ED3L/RV-KE2R3-24VDC

Description type for outlet cover with VRE valve.

**Operating features**

**VRP VALVE**

Outlet pressure ..... : 25 bar / 363 psi

Max. flow ..... : 8 l/min

Filtering ..... : 80 μ

**COLLECTOR KIT CODES**

Type	Code *	Description
KE1R0	5KE1R31230	Kit one section
KE2R0	5KE2R31230	Kit for 2 sections
KE3R0	5KE3R31230	Kit for 3 sections
KE4R0	5KE4R31230	Kit for 4 sections
KE5R0	5KE5R31230	Kit for 5 sections
KE6R0	5KE6R31230	Kit for 6 sections

(\*) codes are referred to BSP thread

**VRE backpressure valve**

Valve is assembled on flow through passage of outlet cover; it's necessary to provides pilot pressure to the actuator.

RV complete (with backpressure valve and tapered plug) outlet cover code: 612300122.

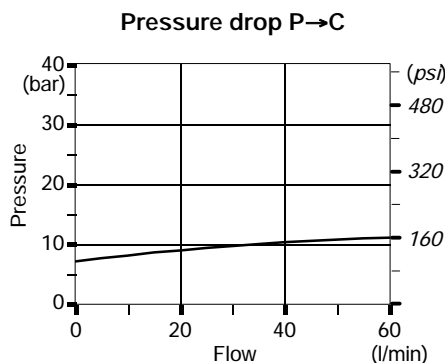
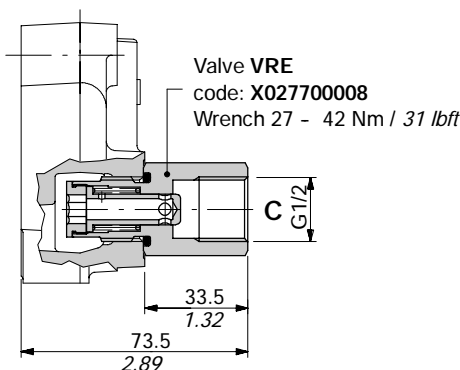
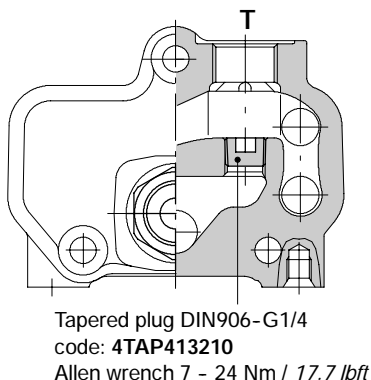

Particular positioner kits for special spools

13NZ kit

Detent in 4<sup>th</sup> position with spool in: available only for spool type 5Y (see page 29).

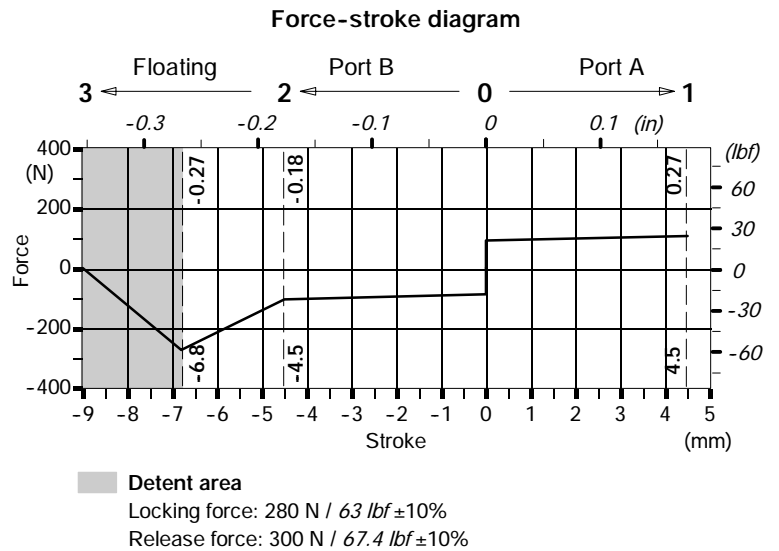
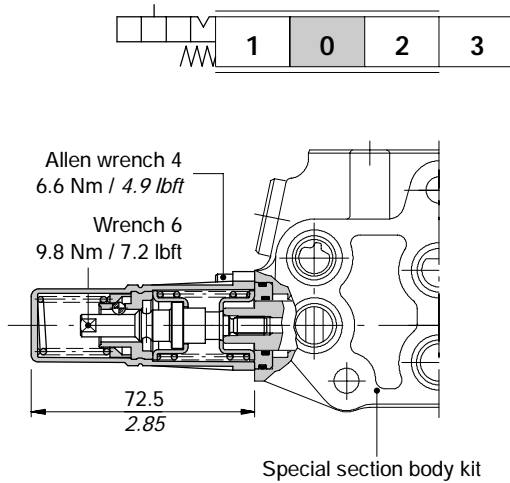

13QN kit

Detent in 4<sup>th</sup> position with spool out: available only for spool type 5BY (see page 30).

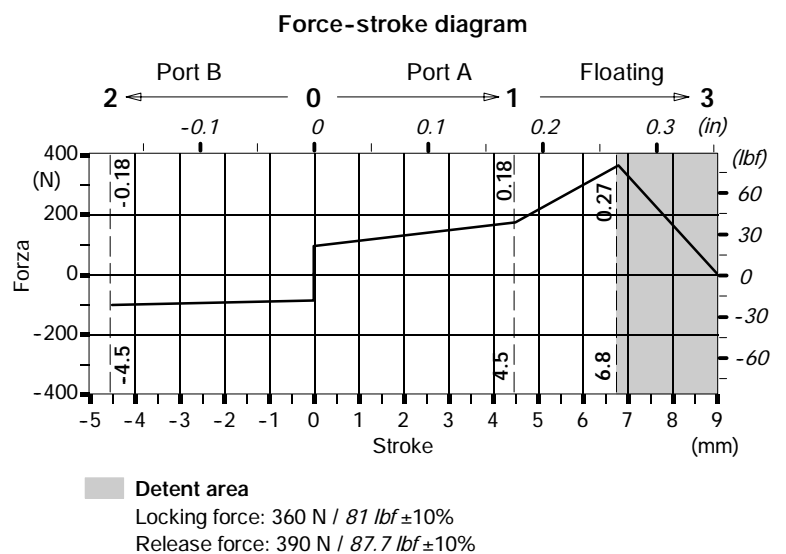
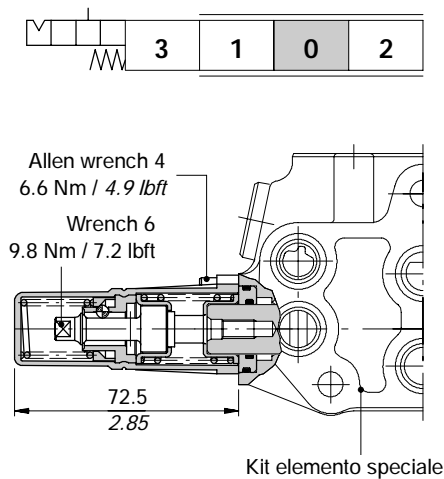

"A" side spool positioners

Particular positioner kits for special spools

13F kit

4<sup>th</sup> position with spool in and spring return to neutral position.  
Available only for spool type **8** (see page 31).

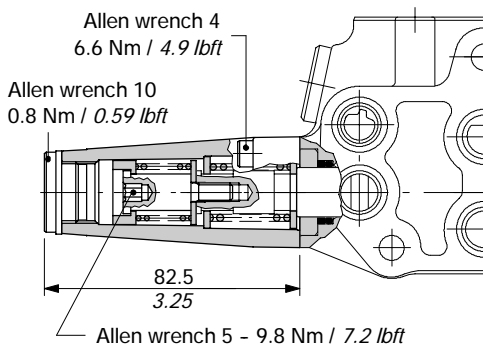
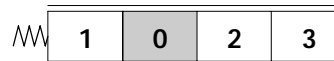

13QNMG3(NO) kit

Detent in 4<sup>th</sup> position with spool out, spring return to neutral position and microswitch operation in both directions.  
The microswitch can be configured with **NO** (normally open) or **NC** (normally closed) contact  
Available only for spool type **5BY** (see page 30).

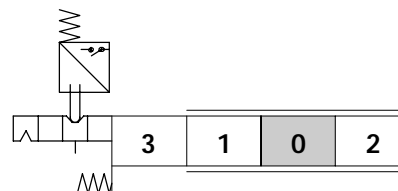
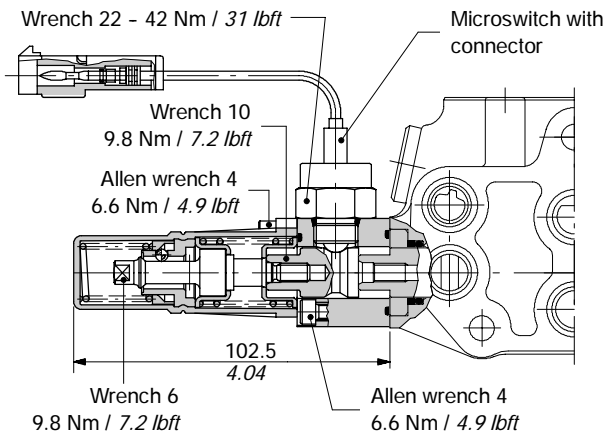

COMPLETE CONTROL CODES

Codes	Contact type	Need connector type	
5V13405660	NO	C07	see page 98
5V13405661	NC	C17	

Operating features

MICROSWITCH

Mechanical life . . . . . : 5x10<sup>5</sup> operations  
Electric life (resistive load) . . : 10<sup>5</sup> operations - 7A / 13.5VDC  
: 5x10<sup>4</sup> operations - 10A / 12VDC  
: 5x10<sup>4</sup> operations - 3A / 28VDC

Particular positioner kits for special spools

13QNMG3(NO) kit

Spare parts

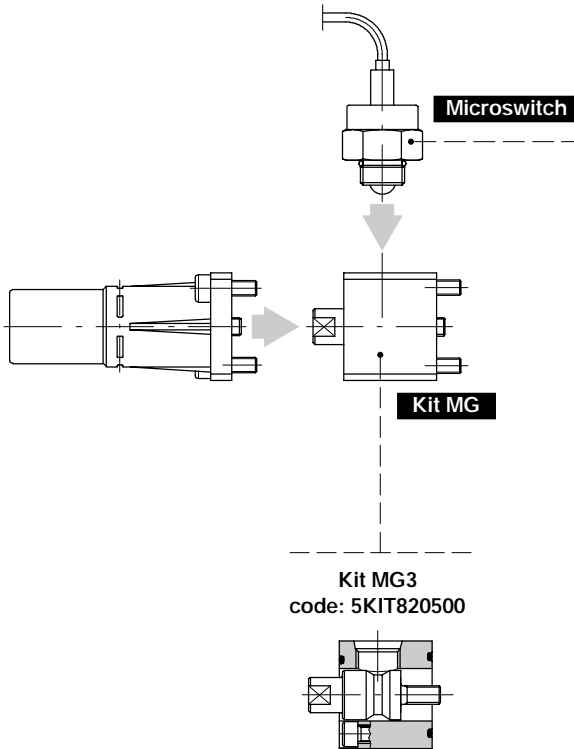

**Standard microswitches: Flying leads with connector**

Normally open (NO)  
code 4MIC730  
with PACKARD W-PACK  
female connector with male end

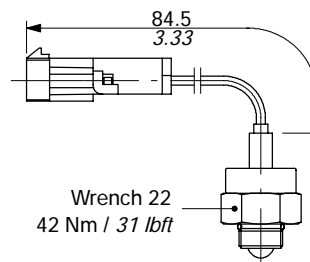

Normally closed (NC)  
code 4MIC740  
with PACKARD W-PACK  
male connector with female end

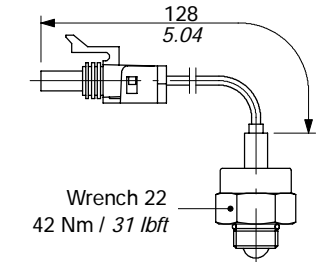

**Special microswitches: moulded-in connector**

Normally open (NO) code 4MIC731  
or normally closed (NC) code 4MIC741  
With PACKARD W-PACK  
female connector with female end

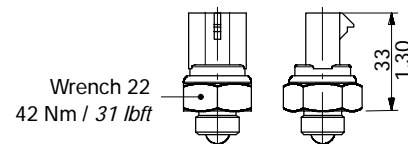

The microswitches with moulded-in connector are not interchangeable with the flying leads ones since these need a different connector: C40 (see page 98).

"A" side spool positioners

Particular positioner kits for special spools

With electromechanical lock

The positioners for special spools (13NZ, 13QN), are also available with spool electromechanical lock in neutral position; if coil is excited the spool can be operated.

For kit K, coils features and dimensions, see page 38: for informations contact Sales Department.

**COIL CODES**

Voltage	CONNECTION TYPE		
	ISO4400	Deutsch DT	Packard M-Pack
12 VDC	2X4300012	2X4300014	YSOL300013
24 VDC	2X4300024	2X4300026	YSOL300025
Need connector type (see page 98)	C02	C19	C20

**13NZ positioner kit**  
(see page 45)  
for spool type 5Y

**13QN positioner kit**  
(see page 45)  
for spool type 5BY

**Kit K**  
Complete actuator kit,  
code: **5KIT810600**

Special section body kit depending on used spool: for information contact Sales Department.

Lever controls

L type

Aluminium lever pivot box with protective rubber bellow; it can be rotated 180° (configuration L180).

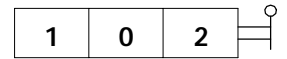
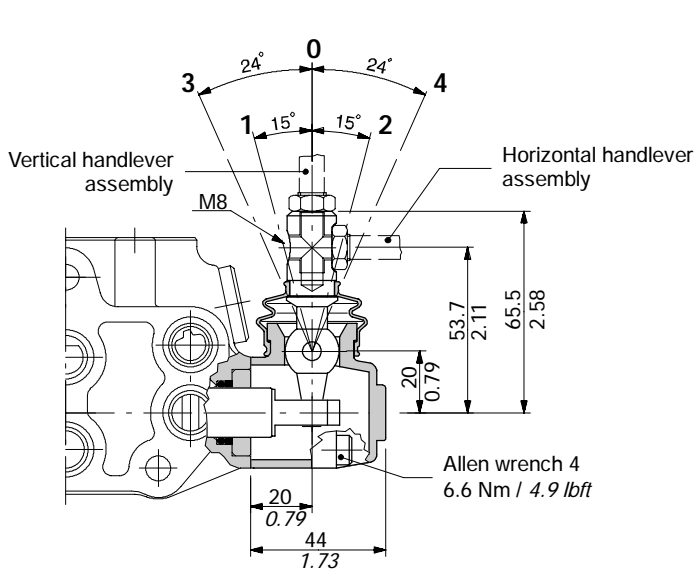

Configuration L180

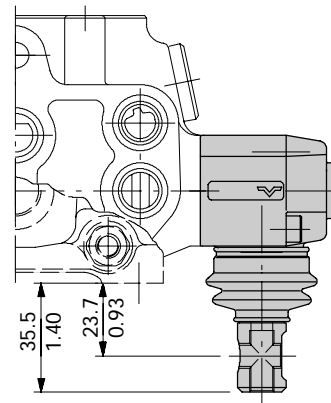

LM10 type

To be use with M10 handlever.  
It can be rotated 180° (configuration LM10180).

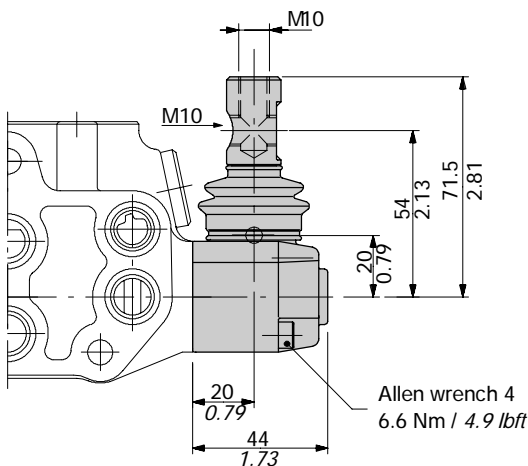
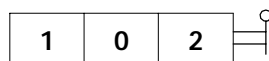

LF1 type

With spool stroke adjustment in position 12 (P→A).  
It can be rotated 180° (configuration LF1180).

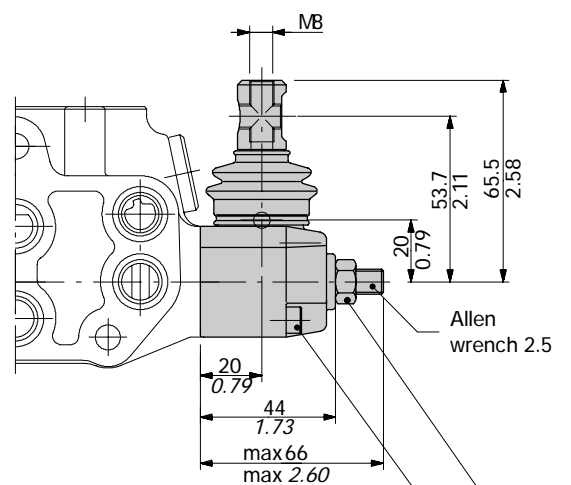
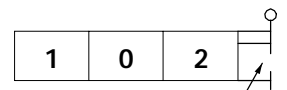

Allen wrench 4 - 6.6 Nm / 4.9 lbf  
Wrench 13 - 24 Nm / 17.7 lbf

## "B" side options

### Lever control

#### LFG5 type

Cast iron lever pivot box with protective rubber bellow; it's complete of two screws for spool stroke adjusting in both directions. It can be rotated 180° (configuration LFG5180).

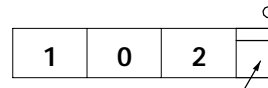
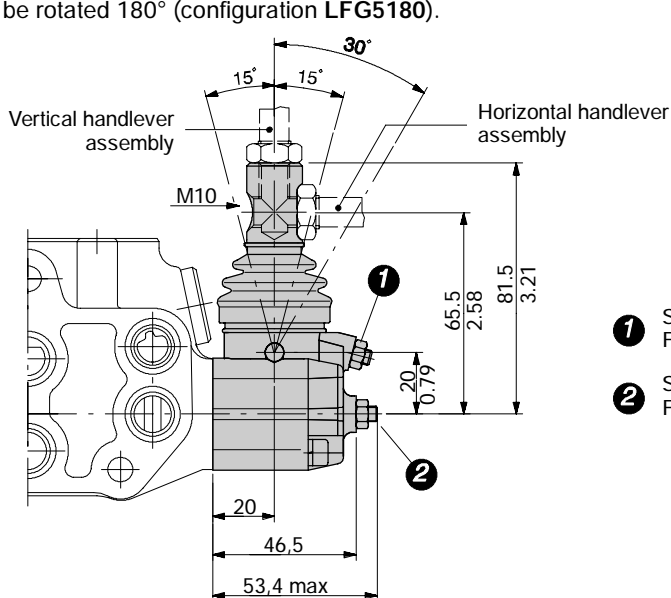

- 1** Stroke end screw for position 2 (P→B): allen wrench 2.5  
Fixing nut: wrench 8 - 6.6 Nm / 4.9 lbft
- 2** Stroke end screw for position 1 (P→A): allen wrench 2.5  
Fixing nut: wrench 8 - 6.6 Nm / 4.9 lbft

#### LB1 type

Steel construction, with pivot placed down.  
Assembling with 5B and 5BY type spool is not possible.

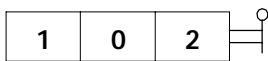
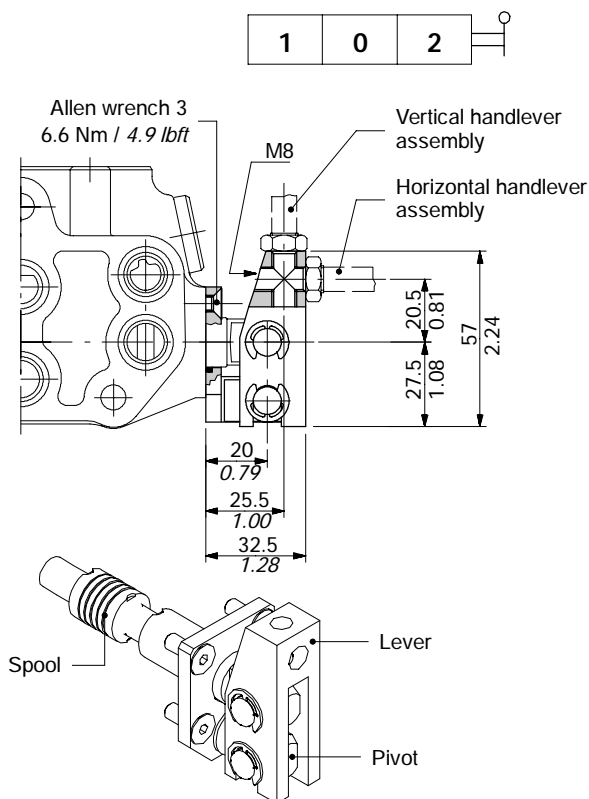

#### LB3 type

Steel construction, with pivot placed above.  
Assembling with 5B, 5BY type spool and with port valves on port B, is not possible

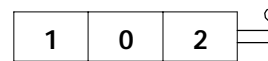
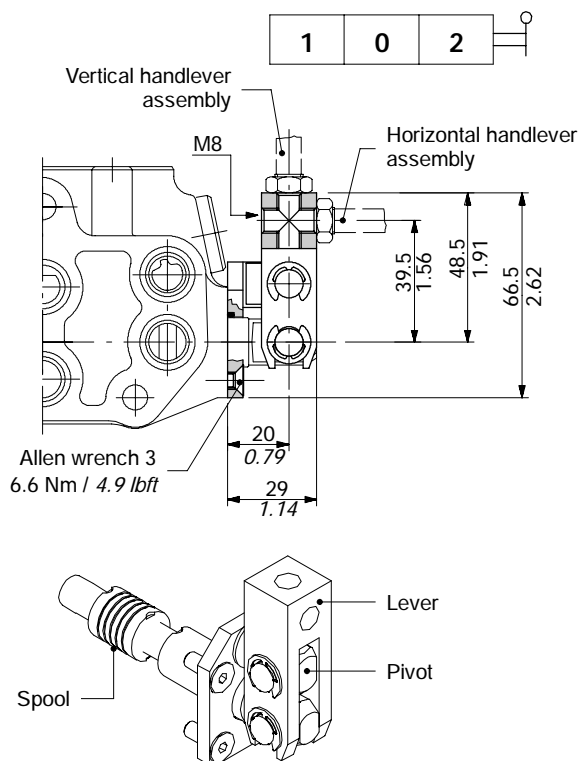

**Safety lever control**

Safety levers with lock in neutral complete with handlever; lift handlever knob to operate.

**LEB type**

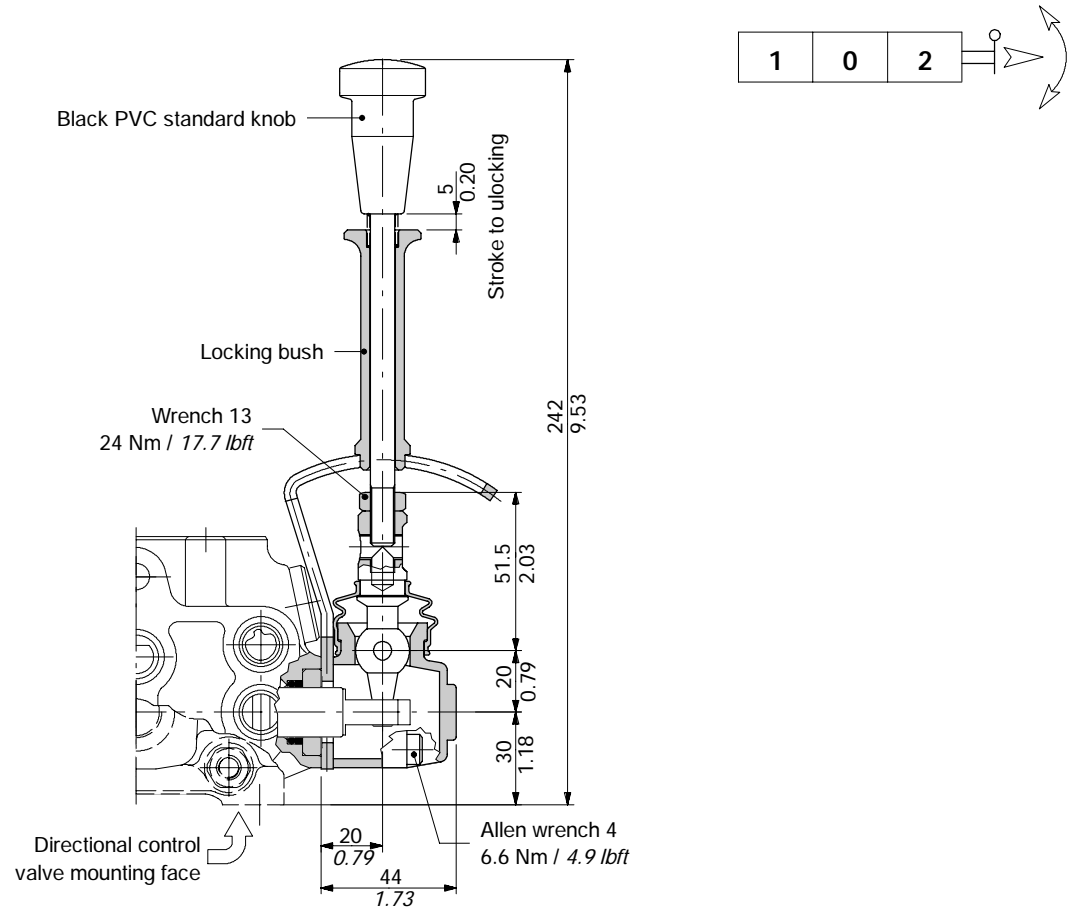

**LUP type**

Available as LUP(R150) configuration, with length L = 150 mm / 5.91 in and red knob: code 5LEV805010.

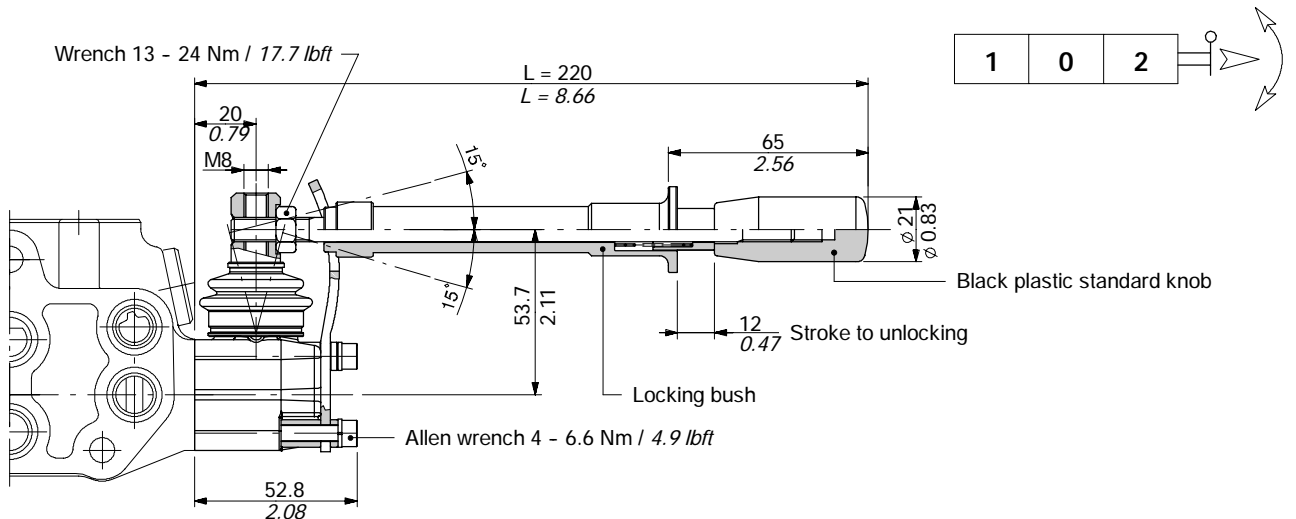

"B" side options

Controls prearrangement

SL type

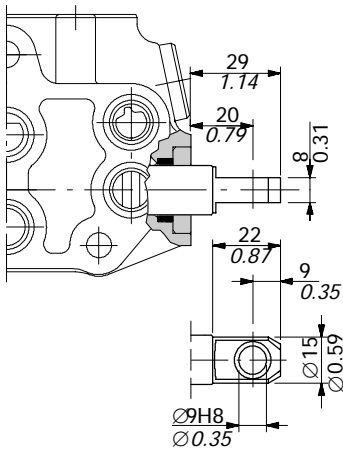
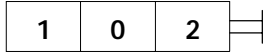

SLP type

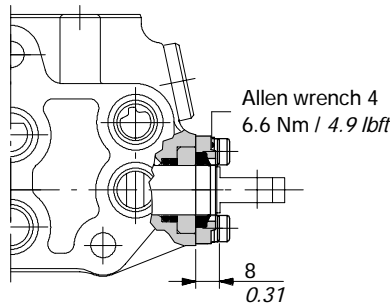
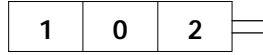

Mechanical control with dust-proof plate kit.

SLCZ type

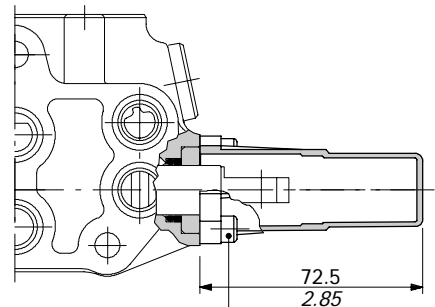
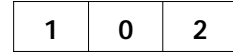

Allen wrench 4 - 6.6 Nm / 4.9 lbft

Protection cap usable with pneumatic, electropneumatic, and electrohydraulic spool positioners.

TQ cable remote control kit

Waterproof cap prearranged for remote control with flexible cable.

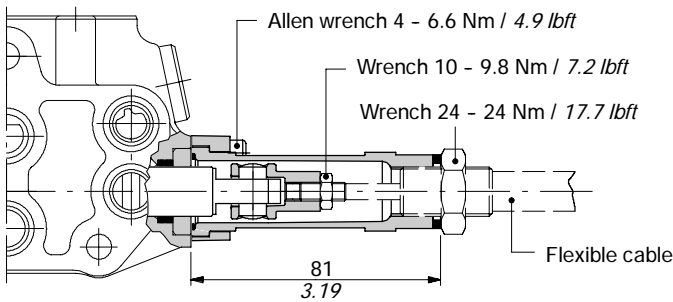
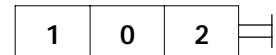

NOTE - For further information about remote cable control, require related documentation.

Example of cable control

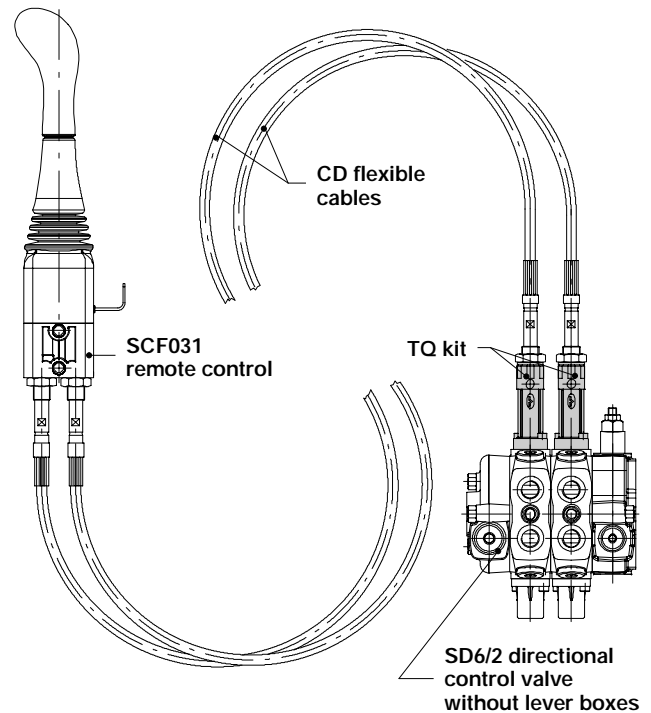

**LCB joystick**

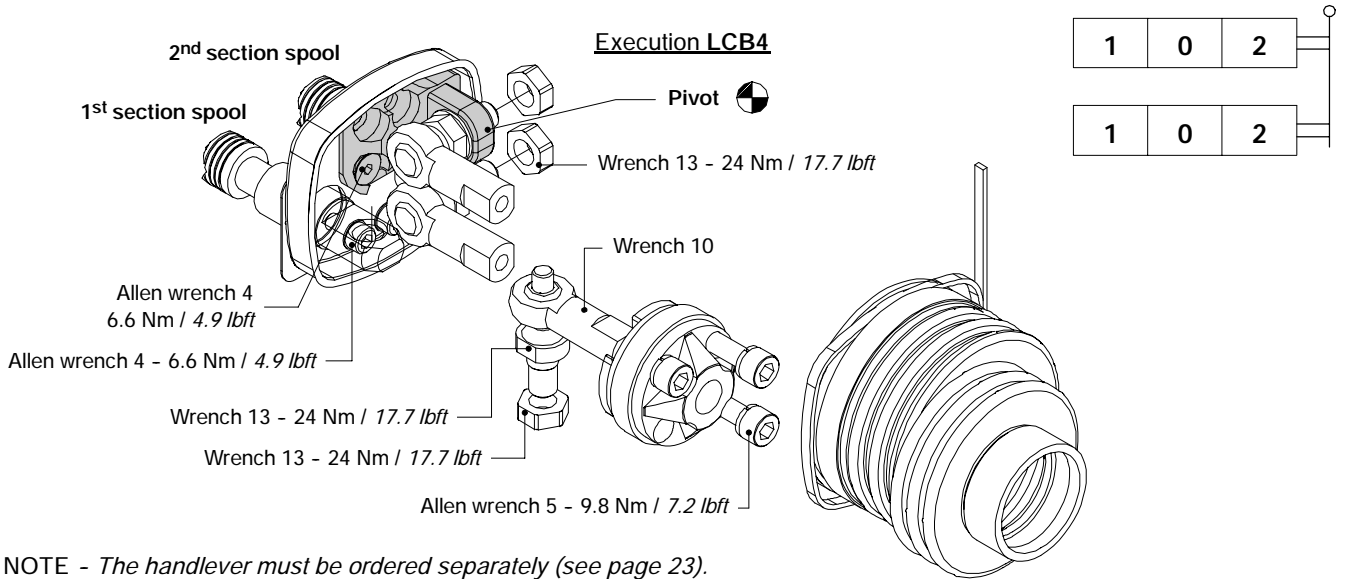

NOTE - The handle lever must be ordered separately (see page 23).

**Dimensions and movement scheme**

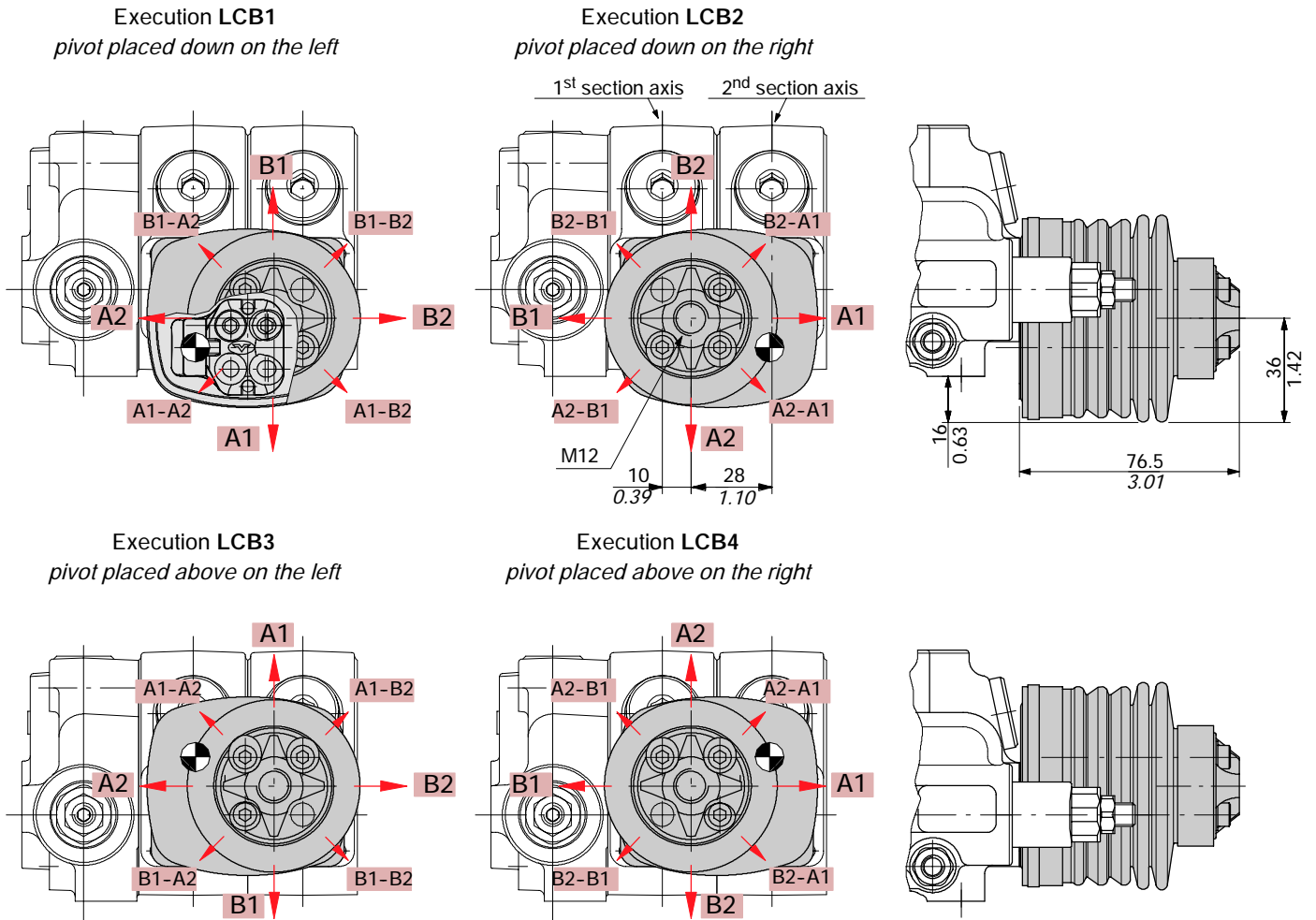

NOTE - Due to limited space in case of LCB3 or LCB4 configuration the assembly of ports service relief valves is not possible.

## Complete controls

### 8ESN solenoid control

Direct control by double solenoid with spring return to neutral position, available with emergency manual override. It's necessary special spool and standard body (body kit without spool seals).

#### Description example:

EL SD6 / P - 1 8ESN LES P1(G3 - 125) - 24VDC

2.

3.

4.

5.

6.

7.

1.

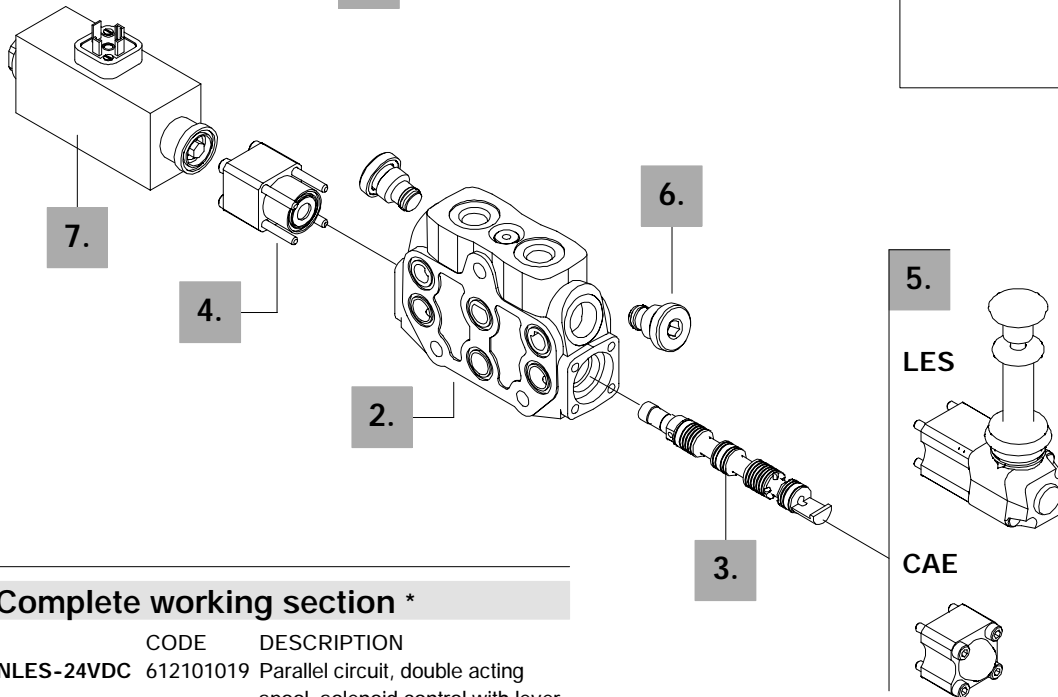

#### 1. Complete working section \*

TYPE	CODE	DESCRIPTION
P-18ESNLES-24VDC	612101019	Parallel circuit, double acting spool, solenoid control with lever

#### 2. Working section kit \*

TYPE	CODE	DESCRIPTION
P/IM-ES	5EL106300A	Parallel circuit

#### 3. Spools

TYPE	CODE	DESCRIPTION
1(ESN)	3CU2210050	Double acting, 3 positions, with A and B closed in neutral position
2(ESN)	3CU2225050	Double acting, 3 positions, with A and B open to tank in neutral position

#### 4. Connection kit

TYPE	CODE	DESCRIPTION
8ESN	5V08012	For solenoid joint, with spring return in neutral position

NOTE (\*) - Codes are referred to **BSP** threads.

#### 5. "B" side options

TYPE	CODE	DESCRIPTION
LES	5LEV106410	Safety lever pivot box for manual operation
CAE	5COP206100	Endcap

#### 6. Port relief valves

For codes please refer to page 23.

#### 7. Solenoid

TYPE	CODE	DESCRIPTION
10.5VDC	XSOL314310	Nominal voltage 10.5VDC
12VDC	XSOL314312	Nominal voltage 12VDC
24VDC	XSOL314324	Nominal voltage 24VDC
192VDC	XSOL314192	Nominal voltage 192VDC; (for 220 VAC supply)

8ESN solenoid control

Electric wiring example

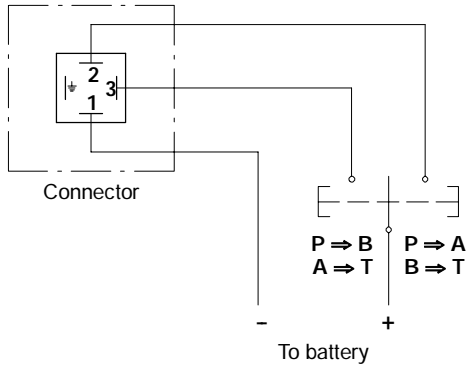

8ESNLES kit

with safety lever pivot box



8ESNCAE kit

with encadp

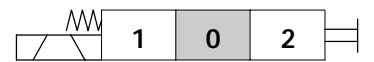

Operating condition diagram

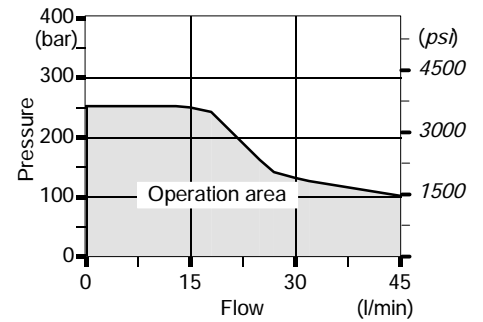

Operating features

CONTROL

Internal leakage A(B)→T

( $\Delta p = 100 \text{ bar} - 1450 \text{ psi} / T = 40^\circ\text{C}$ ) :  $10 \text{ cm}^3/\text{min} - 0.61 \text{ in}^3/\text{min}$

COIL

Nominal voltage tolerance : +10%

Power rating : 65 W

Coil insulation : class H

Duty cycle : 100%

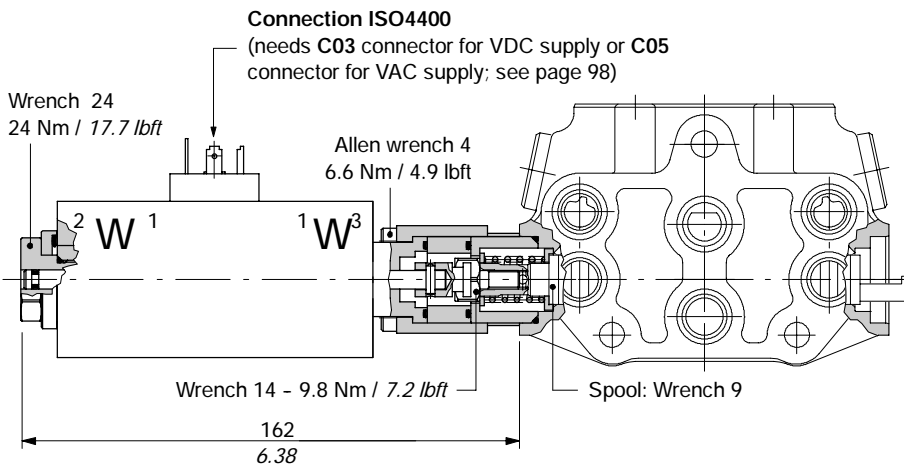

LES

Manual operation:  
lift the bush to lever  
unlocking

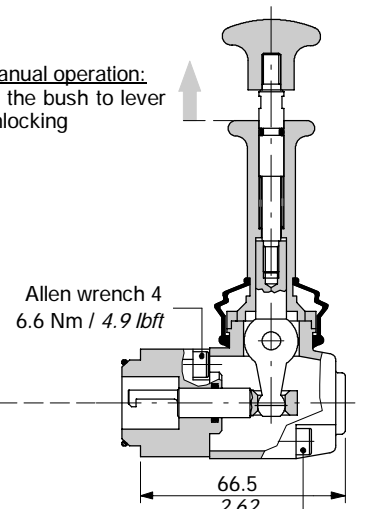

CAE

Allen wrench 4  
6.6 Nm / 4.9 lbf

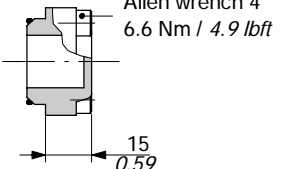

## Complete controls

### 8ES solenoid control

Solenoid direct control with spring return to neutral position; it needs special spools and standard working section body (body kit without seals on spool).

#### Description example:

EL SD6 / P - 1 8ES3 4 P1(G3 - 100) - 12VDC

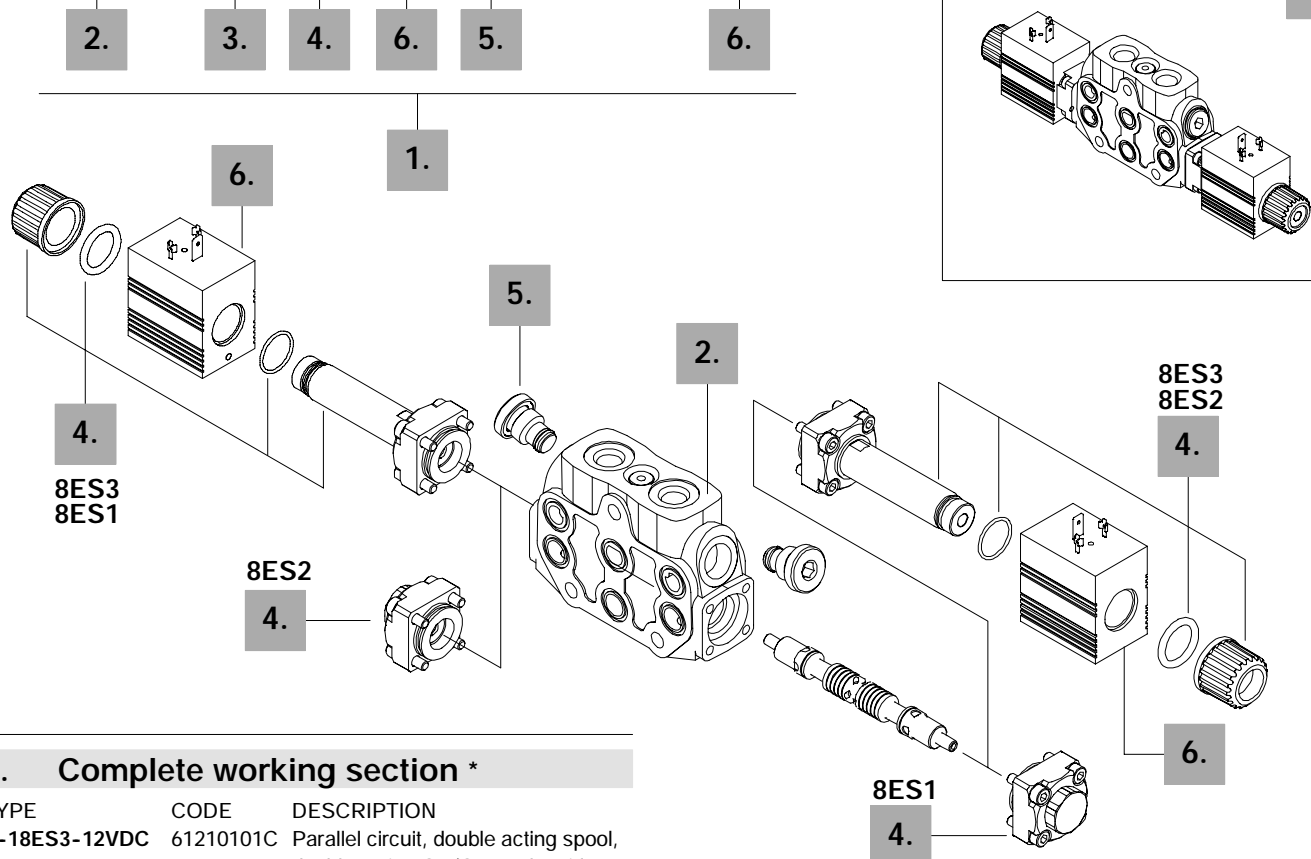

#### 1. Complete working section \*

TYPE	CODE	DESCRIPTION
P-18ES3-12VDC	61210101C	Parallel circuit, double acting spool, double acting ON/OFF solenoid control

#### 2. Working section kit \*

TYPE	CODE	DESCRIPTION
P/IM-ES	5EL106300A	Distribuzione in parallelo

#### 3. Spools

TYPE	CODE	DESCRIPTION
1(ES)	3CU2210015	Double acting, 3 positions, with A and B closed in neutral position
2(ES)	3CU2225015	Double acting, 3 positions, with A and B open to tank in neutral position

#### 4. Control kit

TYPE	CODE	DESCRIPTION
8ES1	5CAN08026	P→A, with spring return to neutral position
8ES2	5CAN08026	P→B, with spring return to neutral position
8ES3	5CAN08027	Double acting with spring return to neutral position

#### 5. Port valves

For codes please refer to page 23.

#### 6. Coils

TYPE	CODE	DESCRIPTION
<u>With ISO4400 connector</u>		
10.5VDC	4SOL412011	Nominal voltage 10.5VDC
12VDC	4SOL412012	Nominal voltage 12VDC
24VDC	4SOL412024	Nominal voltage 24VDC
<u>With Deutsch series DT connector</u>		
4-10.5VDC	4SOL412111	Nominal voltage 10.5VDC
4-12VDC	4SOL412112	Nominal voltage 12VDC

NOTE (\*) - Codes are referred to **BSP** thread.

8ES solenoid control

Electric wiring example

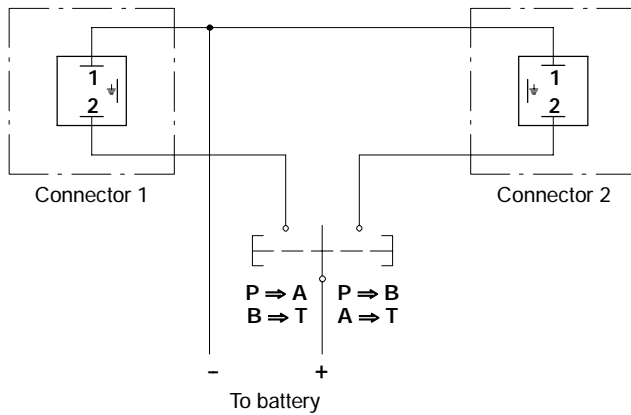

8ES3 kit  
double acting

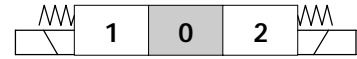

8ES1 kit  
single acting on A

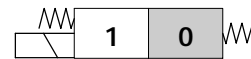

8ES2 kit  
single acting on B

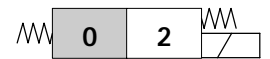

Operating features

CONTROL

Internal leakage A(B)→T

( $\Delta p = 100 \text{ bar} - 1450 \text{ psi} / T = 40^\circ\text{C}$ ) :  $15 \text{ cm}^3/\text{min} - 0.91 \text{ in}^3/\text{min}$

COIL

Nominal voltage tolerance : +10%

Power rating : 36 W

Coil insulation : class H

Duty cycle : 100%

Operating condition diagram

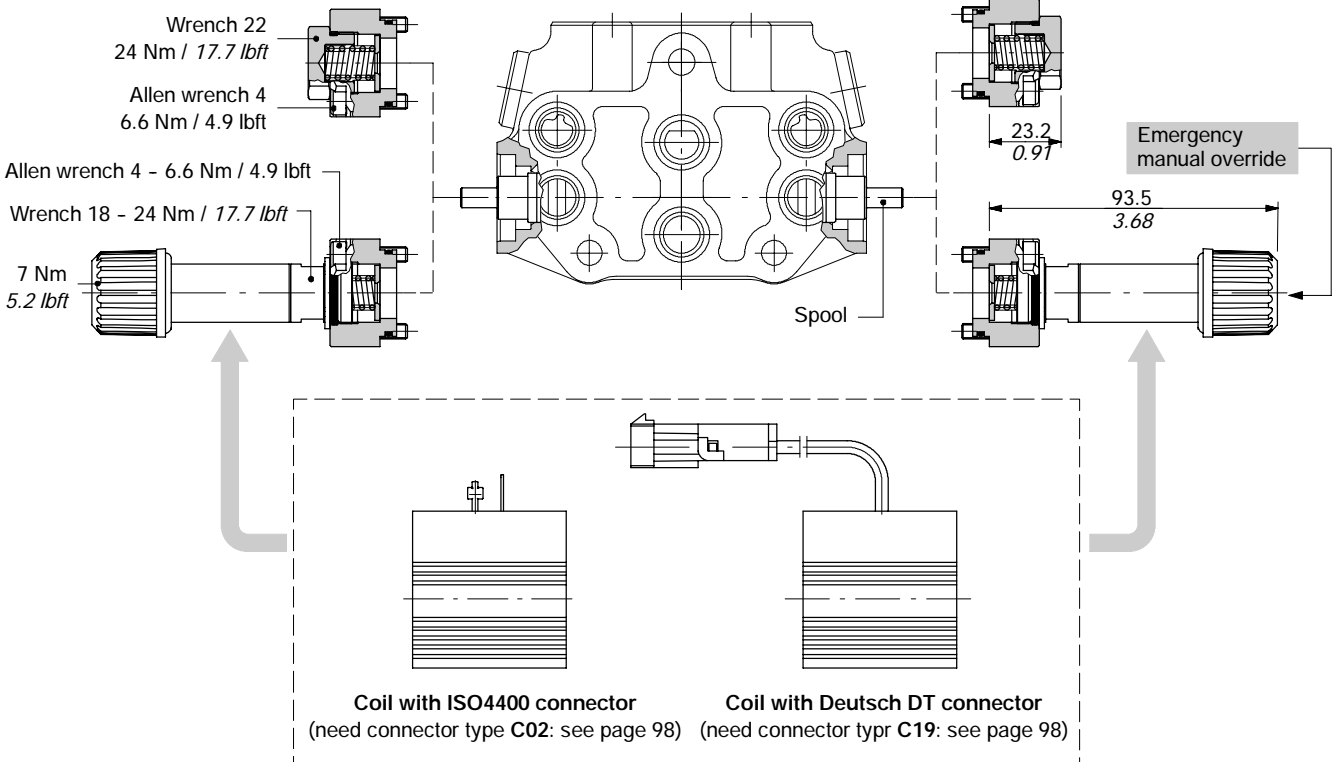
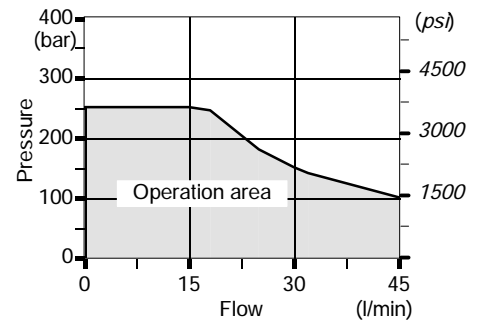

Comandi completi

8IM proportional hydraulic kit:: code 5IDR206010

It can be used with special spools and body kit without seals and ring on spool (standard body) code: 5EL106300A.

It's also available in 8IMF3-SD6 configuration with screws for spool stroke adjustment, code: 5IDR206012.

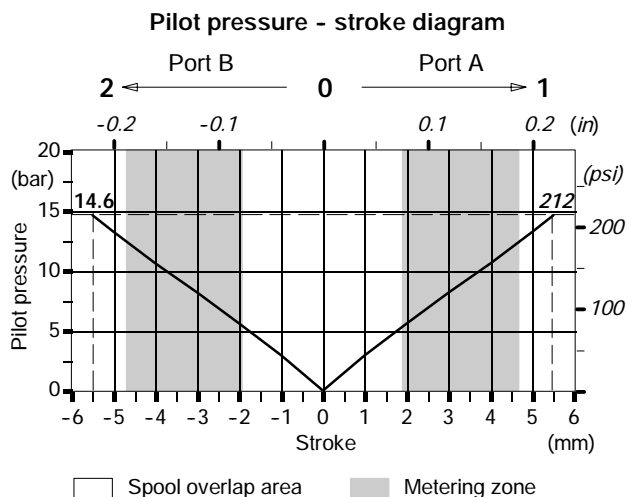
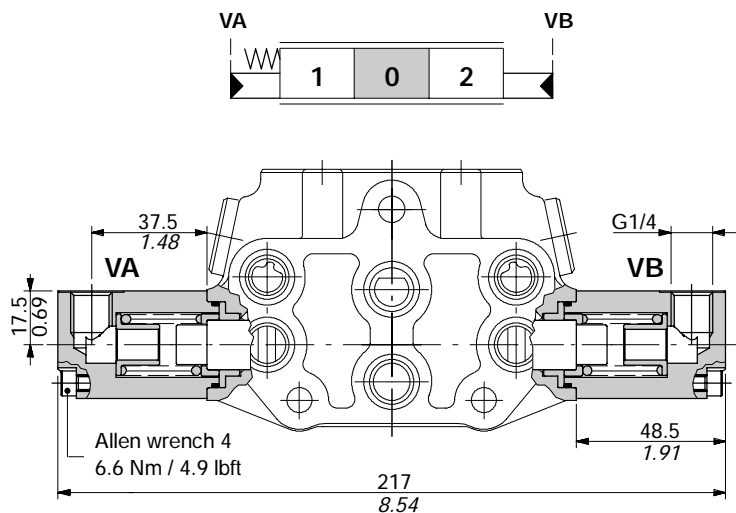

Available spools

TYPE	CODE	DESCRIPTION
1IM	3CU2210420	Double acting, 3 positions, with A and B closed in neutral position
2IM	3CU2225420	Double acting, 3 positions, with A and B open to tank in neutral pos.

Operating features

Pilot pressure : max. 50 bar / 730 psi  
 Internal leakage A(B)→T ( $\Delta p = 100 \text{ bar} - 1450 \text{ psi} / T = 40^\circ\text{C}$ )  
 : max. 6 cm<sup>3</sup>/min - 0.37 in<sup>3</sup>/min

Connection example

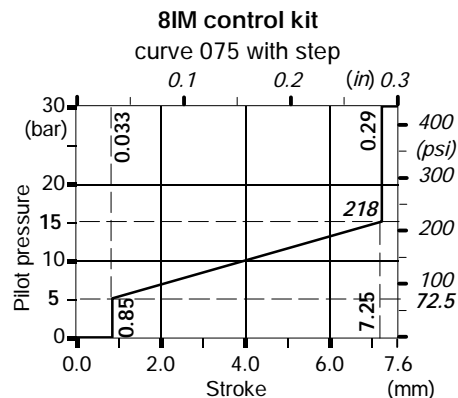
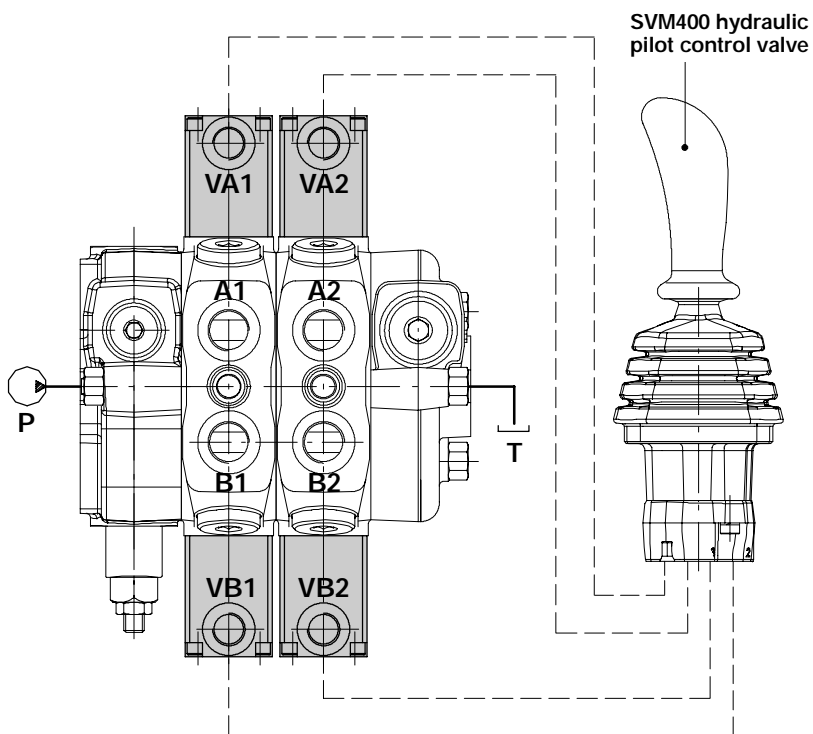

Antishock valves

**P 1 (G 3 - 100)**

- Pressure setting in bar.
- Spring type (2, 3, 4).
- Adjustment type (G, H, Z).
- 1 mounted on port A.
- 2 mounted on port B.
- 3 mounted on ports A and B.

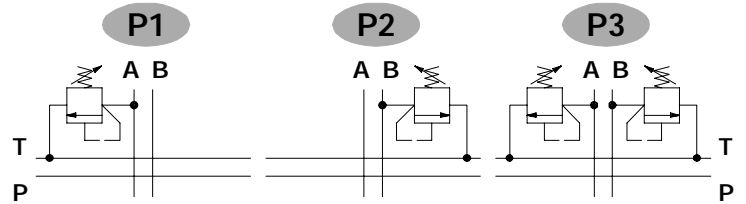

Adjustment type

**G:** with screw

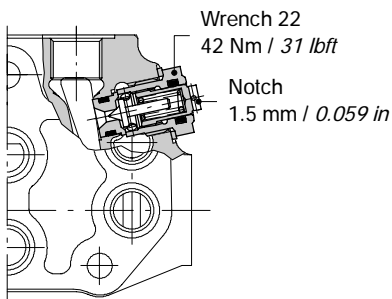

**H:** valve set and locked

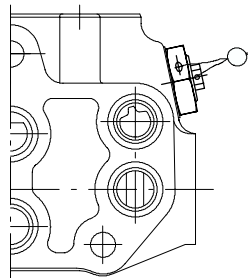

**Z:** tamper proof configuration

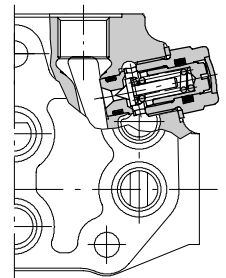

Performance data

**Spring nr. 2 (green band)**

Standard setting: 63 bar / 900 psi

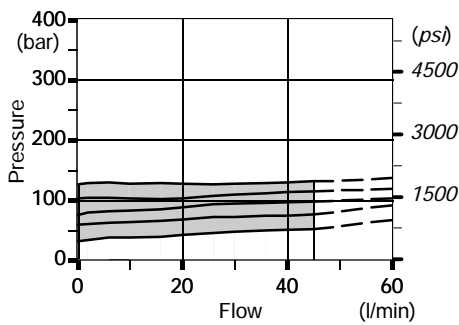

**Spring nr. 3 (blue band)**

Standard setting: 100 bar / 1450 psi

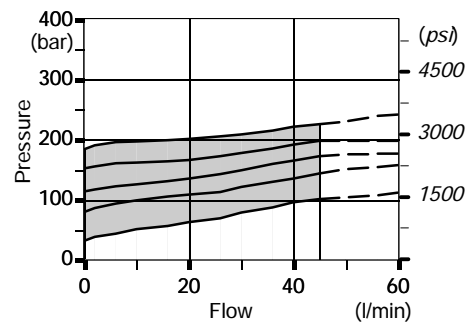

**Spring nr. 4 (red band)**

Standard setting: 200 bar / 2900 psi

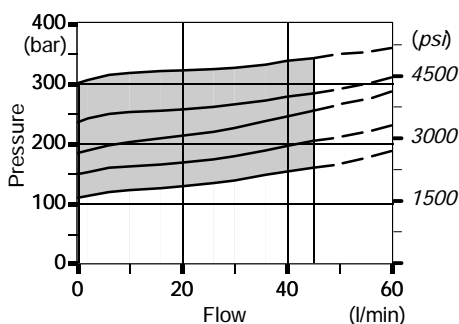

**Time response**

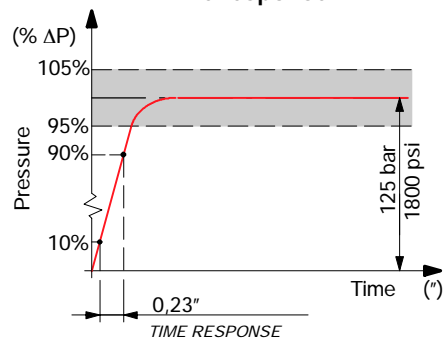

Antishock and anticavitation valves

U 1 ( G 3 - 100 )

- Pressure setting in bar.
- Spring type (2, 3, 4).
- Adjusting type (G, H).
- 1 mounted on port A.
- 2 mounted on port B.
- 3 mounted on ports A and B.

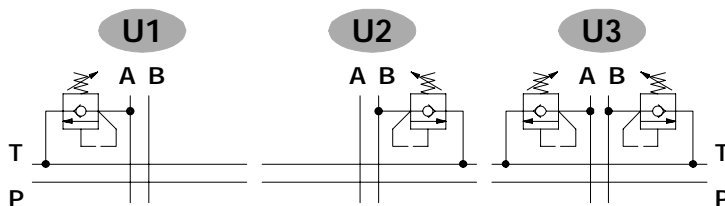

Adjusting type

G: with screw

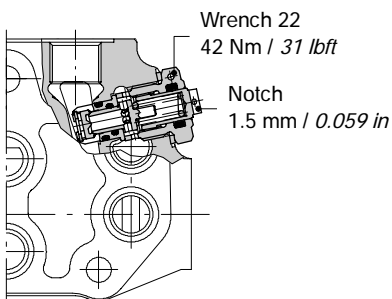

H: valve set and locked

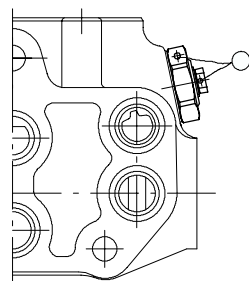

Performance data

Spring nr.2 (green band)

Standard setting: 63 bar / 900 psi

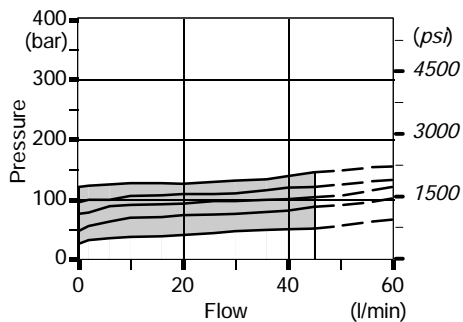

Spring nr.3 (blue band)

Standard setting: 100 bar / 1450 psi

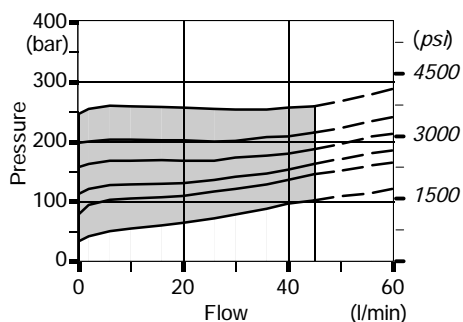

Spring nr.4 (red band)

Standard setting: 200 bar / 2900 psi

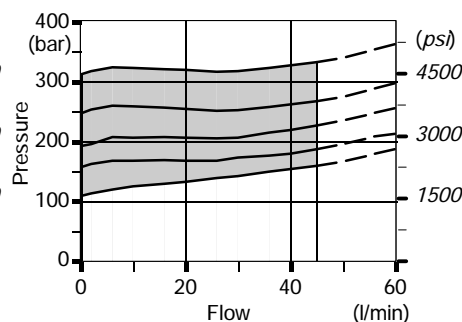

Time response

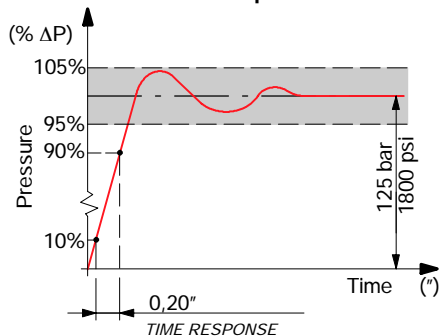

Pressure drop

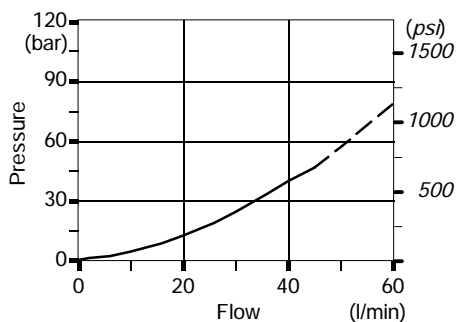

Anticavitation valves

C 1

- 1 mounted on port A.
- 2 mounted on port B.
- 3 mounted on ports A and B.

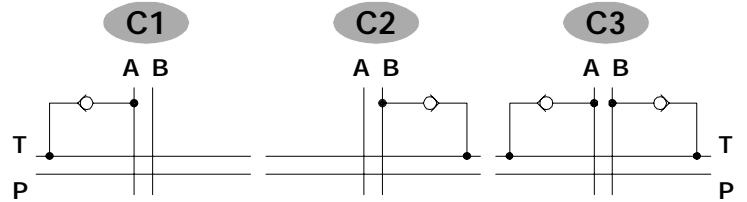
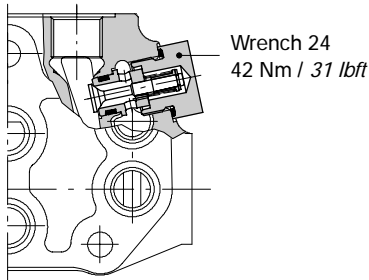

Performance data

Pressure drop

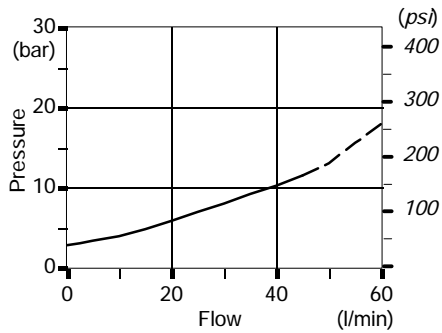

Valve blanking plug

P 1 T

- 1 mounted on port A.
- 2 mounted on port B.
- 3 mounted on ports A and B.

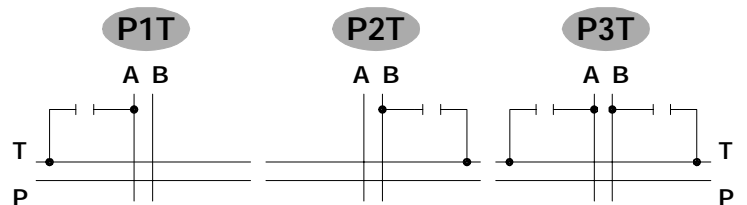
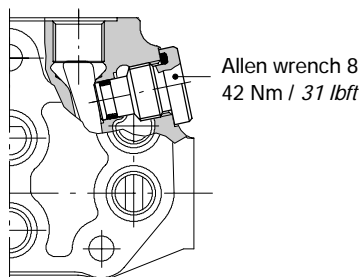

Pilot check valves

Cast iron block with pilot check valves.

**BPS 1**

- 1 mounted on port A.
- 2 mounted on port B.
- 3 mounted on ports A and B.

**BP** direct type  
**BPS** with pre-opening

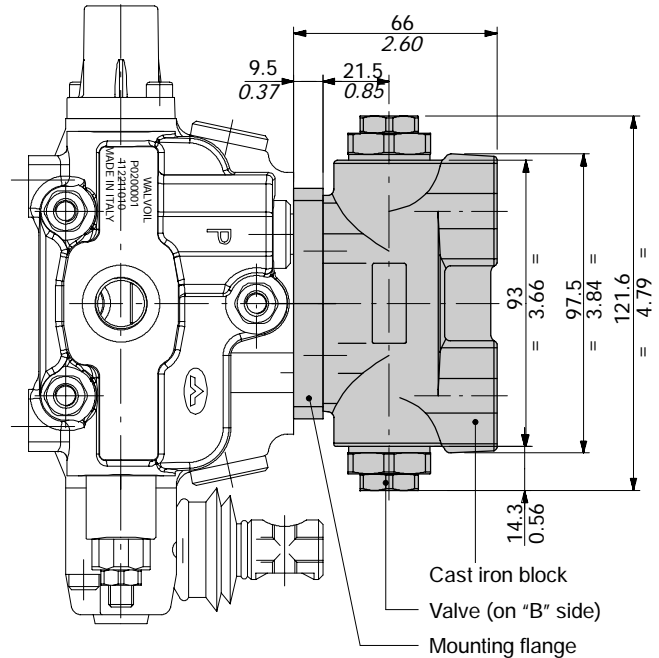
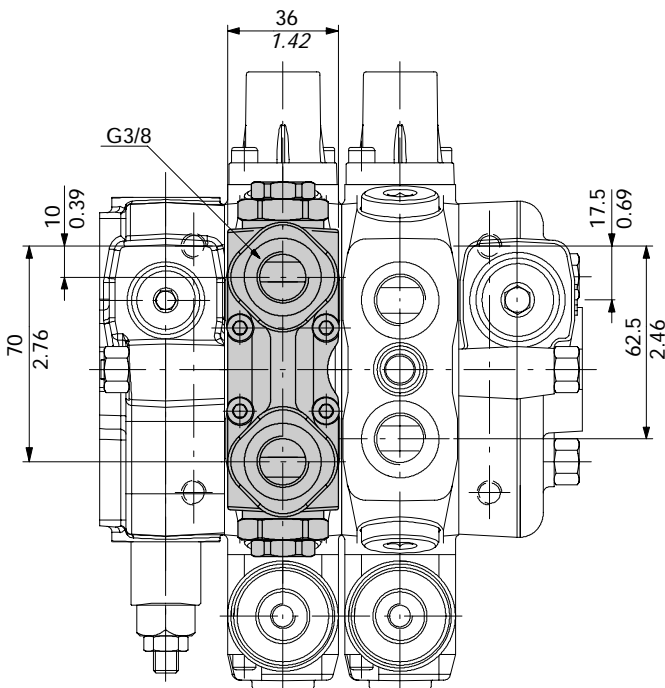
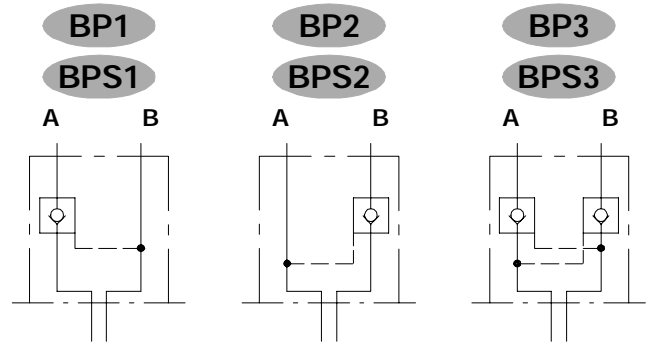

Example of extra machining on working section body

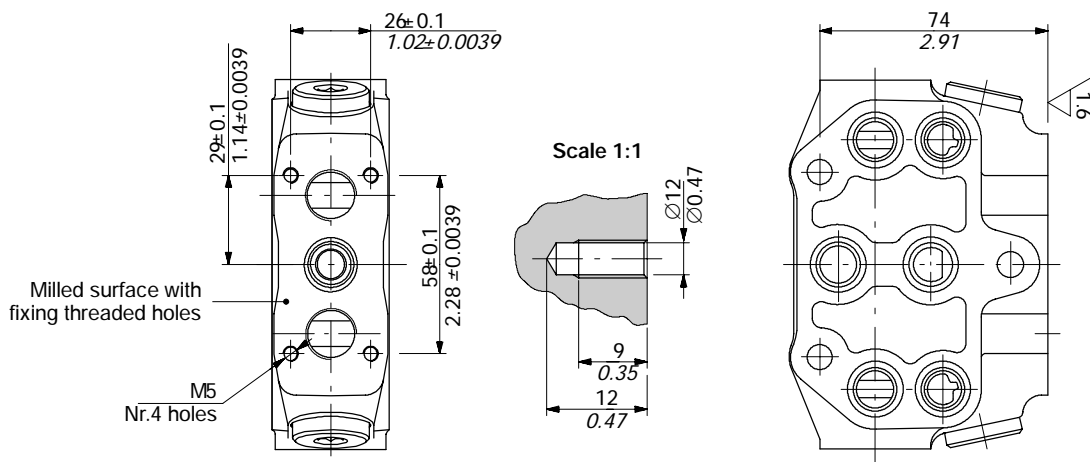

**BP1 configuration**

Example of pressure on port A and port B to tank

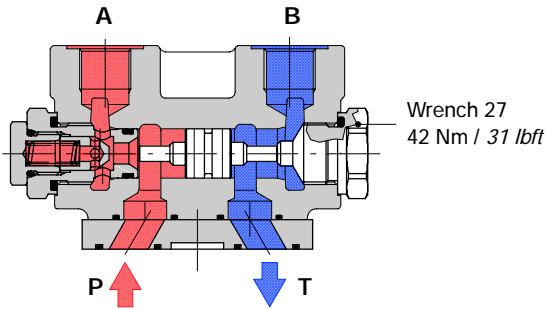

**BP3 configuration**

Example of pressure on port A and port B to tank

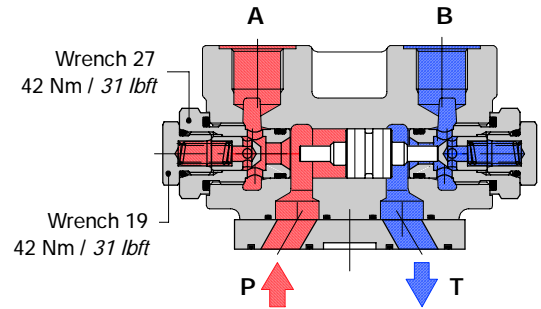

Example of pressure on port B and port A to tank

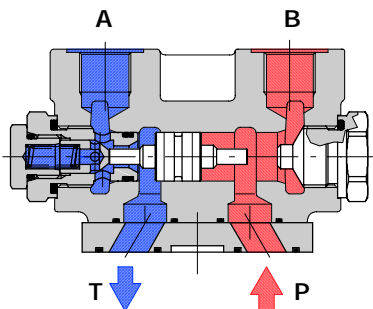

Example of pressure on port B and port A to tank

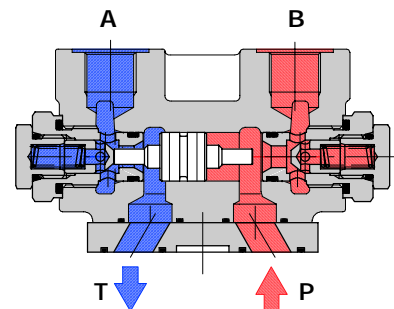

**Performance data**

**BP valve pressure drop**

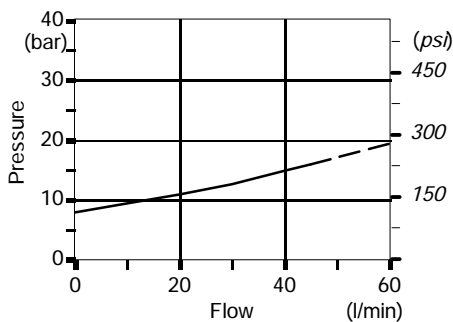

Type	Pilot ratio	
	With pre-opening	Main
BP	/	1 : 5.3
BPS	1 : 16	1 : 3.2

**BPS valve pressure drop**

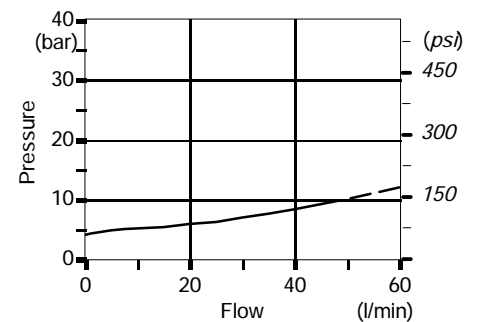

**CS1 mid return manifolds**

Mid return manifolds for directional valve with left and right inlet both; they allow 2 independent circuits with common outlet.

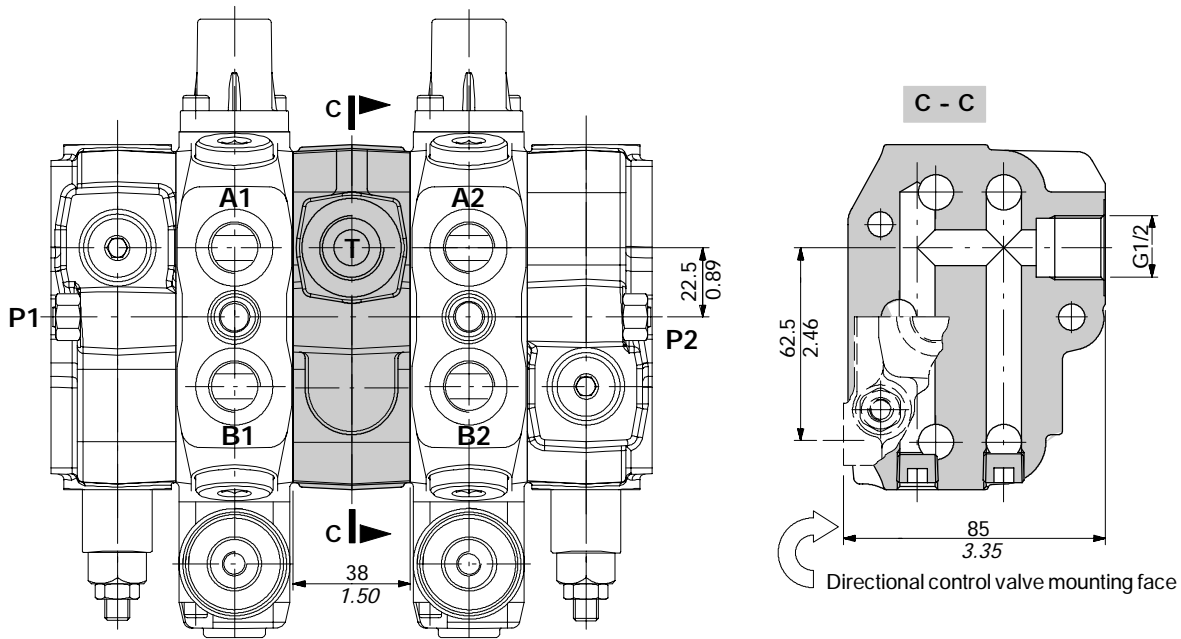

Hydraulic circuit

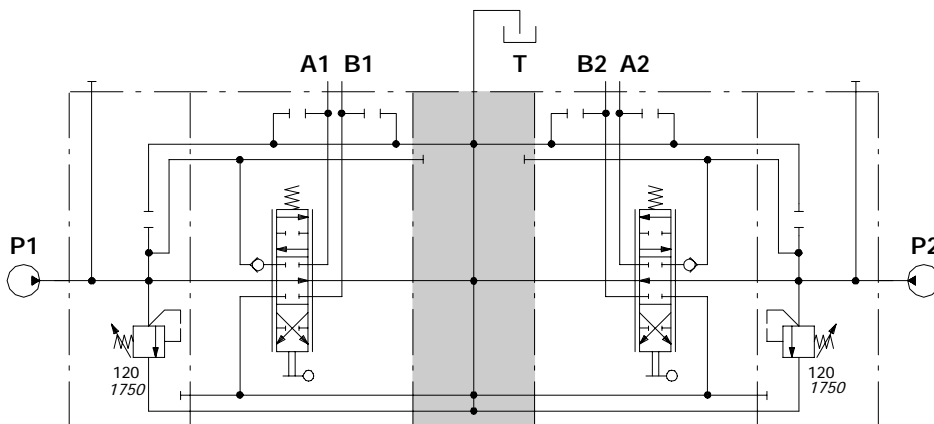

Description example:

SD6/2/AC(YG3-120)/18L/CS1/18L/BC(YG3-120)

**DFG pressure compensated flow divider section**

The flow on the downstream sections can be adjusted from 0 to 40 l/min by means of graduated handwheel; flow exceeding setting goes to tank.

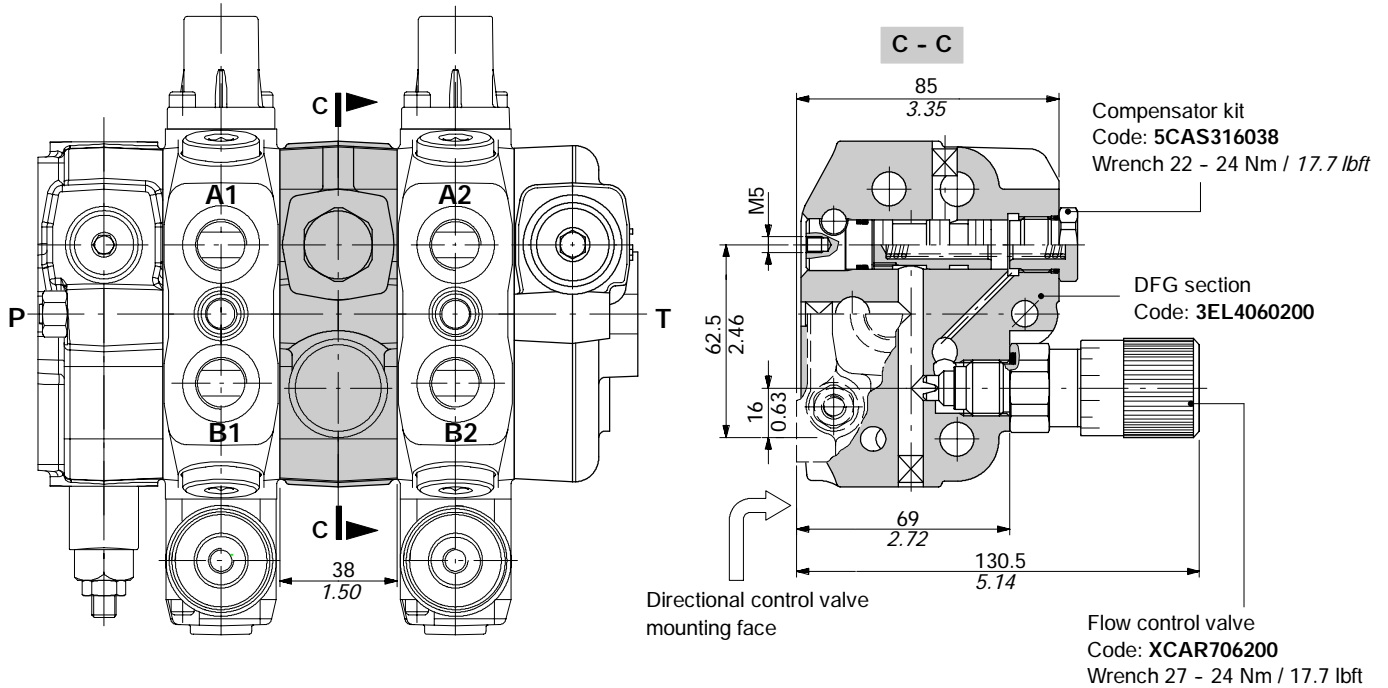

Hydraulic circuit

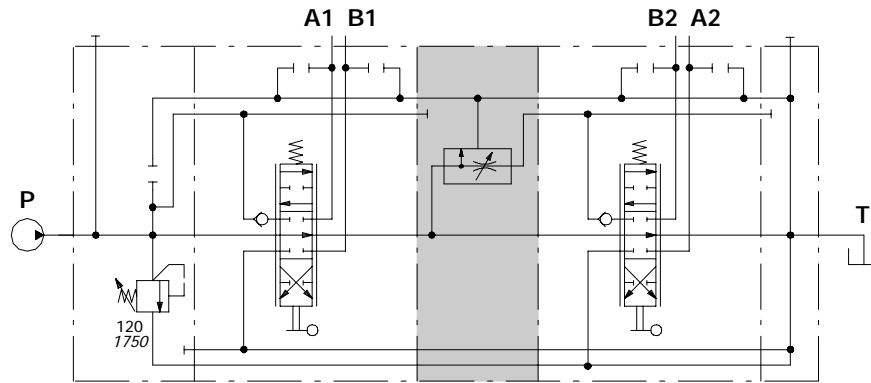

Description example:

SD6/2/AC(YG3-120)/18L/DFG/18L/RC

Flow regulation diagram

$Q_{in} = 45 \text{ l/min} - P_{ut} = 100 \text{ bar} / 1450 \text{ psi}$

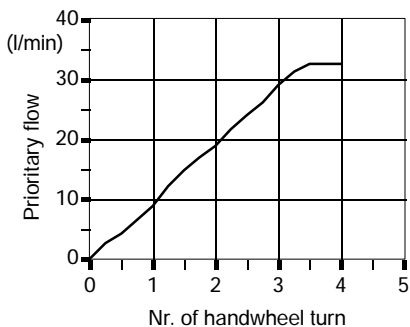

Pressure-flow diagram

$Q_{in} = 45 \text{ l/min}$   
1000 2000 3000 (psi)

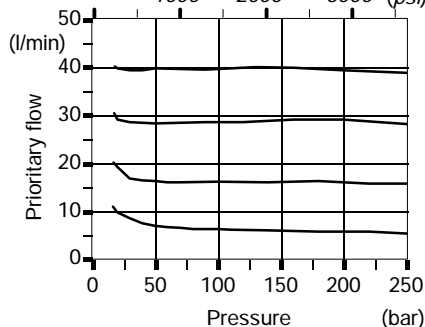

Pressure drop

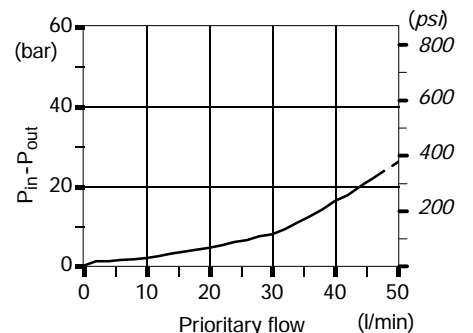

**EI service relief valve section**

The operation of up stream section exclude the EI downstream section.

The pressure of the downstream sections should be adjusted at least 20 bar / 290 psi below the relief valve setting.

Execution EI2 is prearranged for a second inlet.

**Execution EI1**

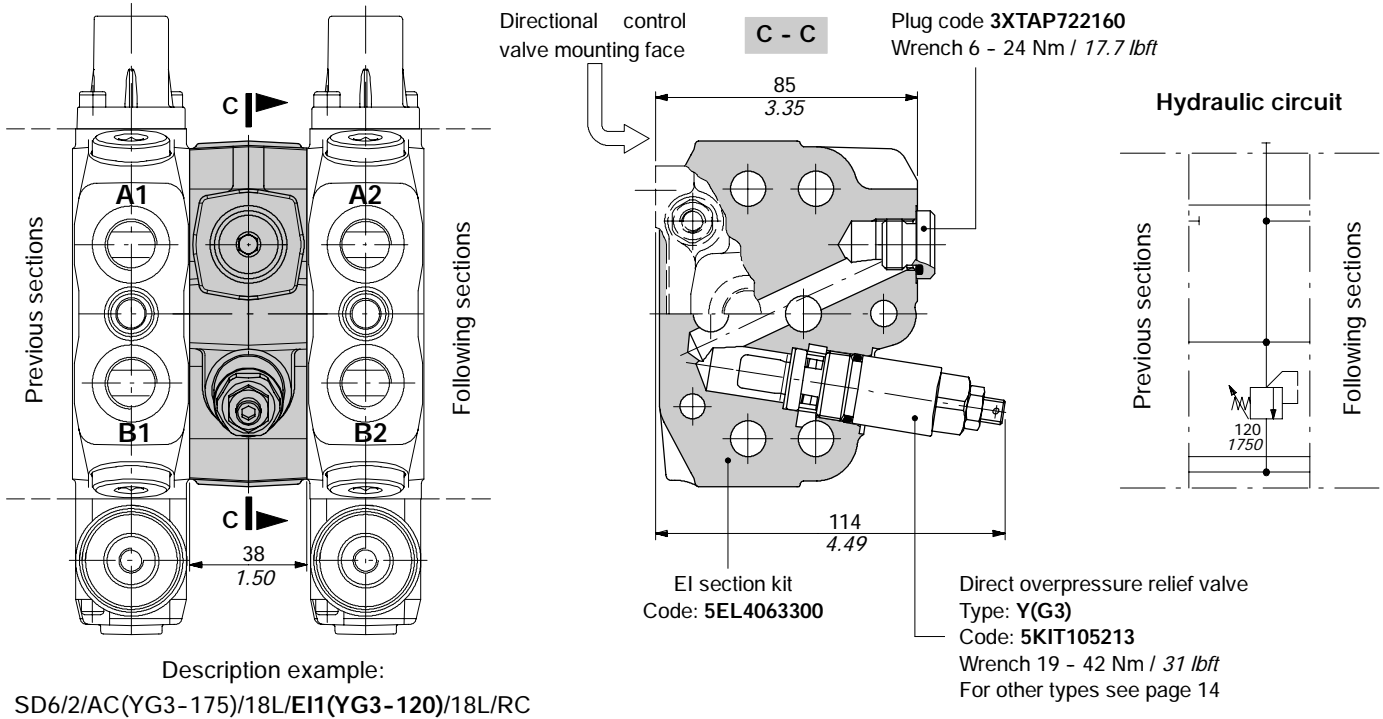

**Execution EI2**

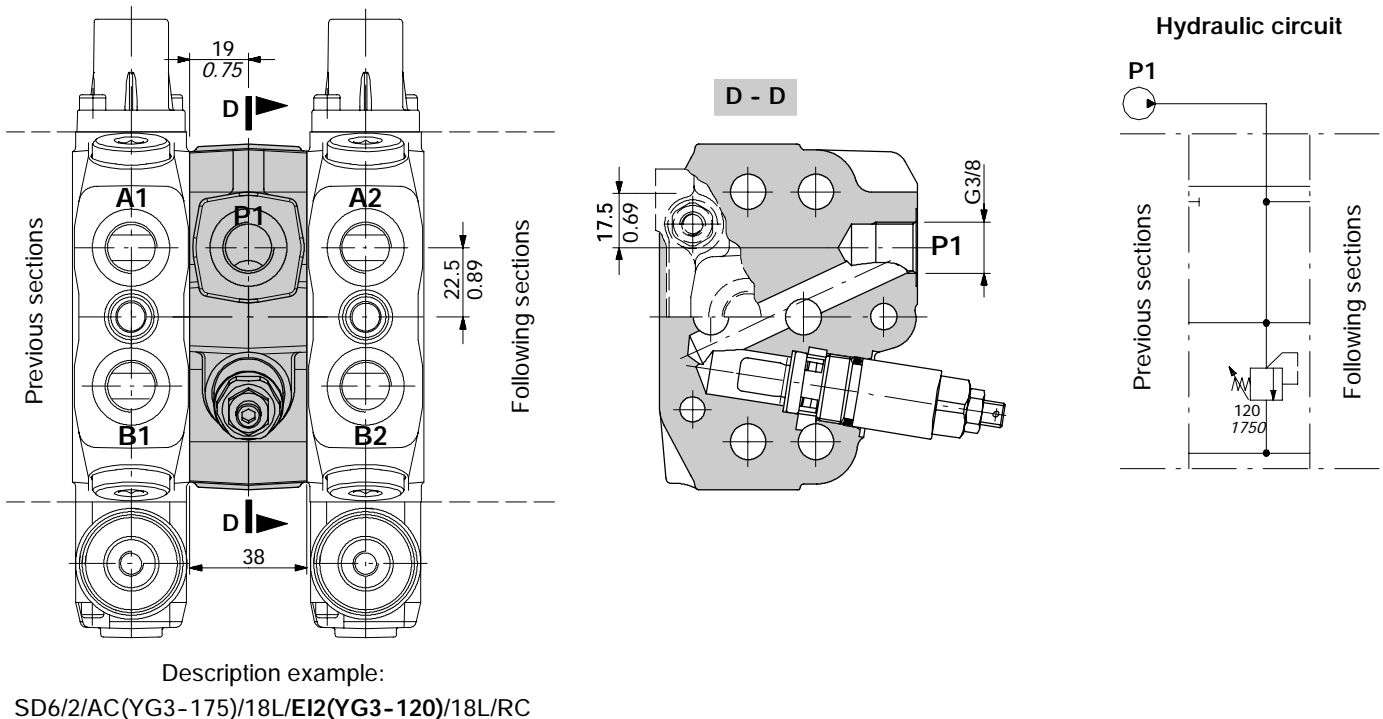

**EVP3 inlet section with regulated flow**

Intermediate inlet section with regulated flow priority valve and exceeding flow in pressure.

From EVP3, the regulated flow is supplied to left side working sections while the exceeding flow is supplied to right side working section.

On EVP3 is incorporate the main relief valve; the regulated flow is adjustable also with the circuit under pressure.

The working sections are assembled with two end cover, the left one is plugged (type RT code 612300112), while the right one has the tank port technical data:

Max. inlet flow = 60 l/min, max. regulated flow = 40 l/min.

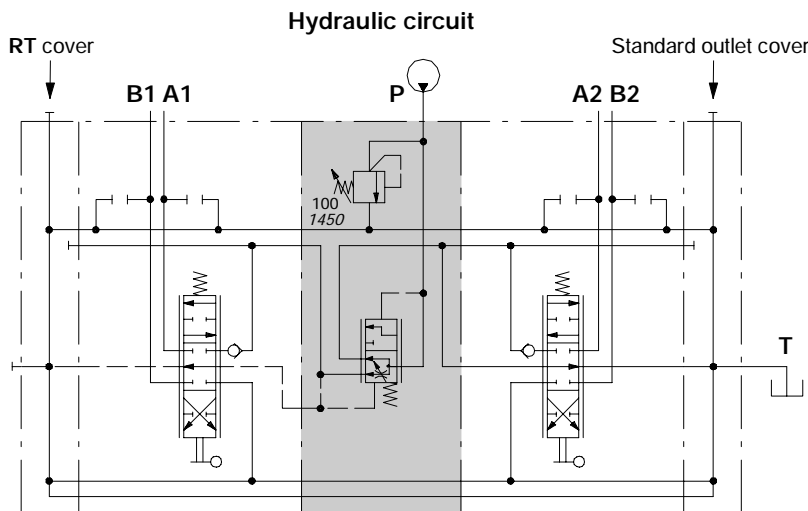
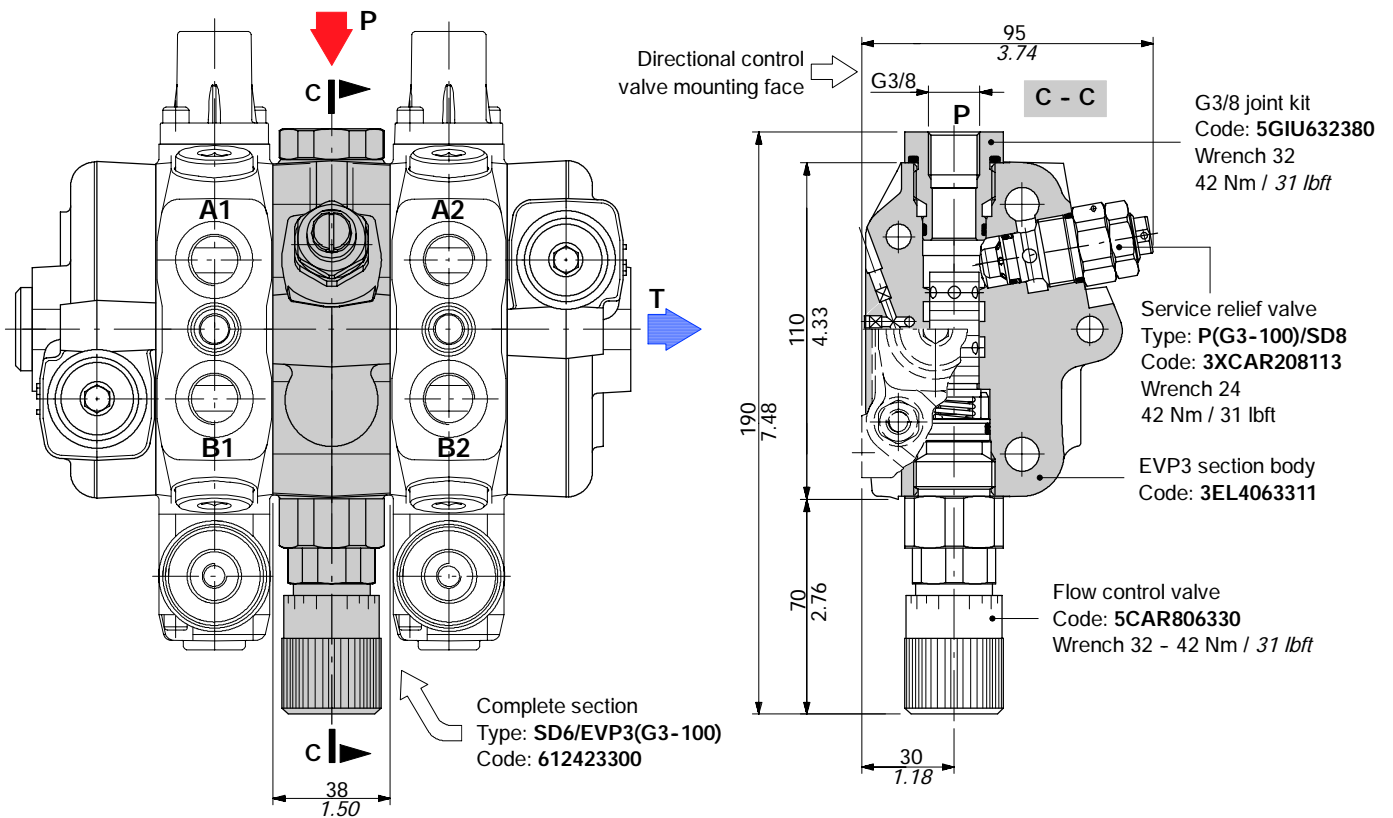

Description example: SD6/2/RT/18L/EVP3(G3-100)/18L/RC

Service relief valve performance data

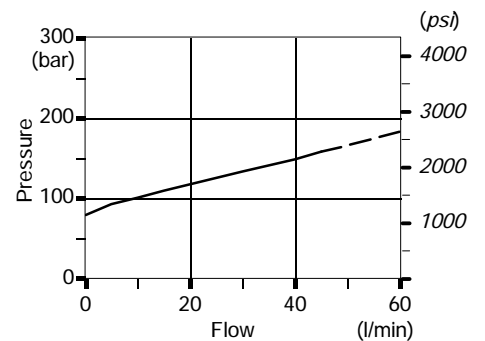

## EVP9 pressure compensated flow control section

Section with pressure compensated 3-ways flow control cartridge valve.

The regulated flow is supplied to down stream sections, while the exceeding flow goes to tank.

max. inlet flow is 45 l/min, max. regulated flow is 30 l/min.

Description example: complete working section EL SD6 / EVP9 1

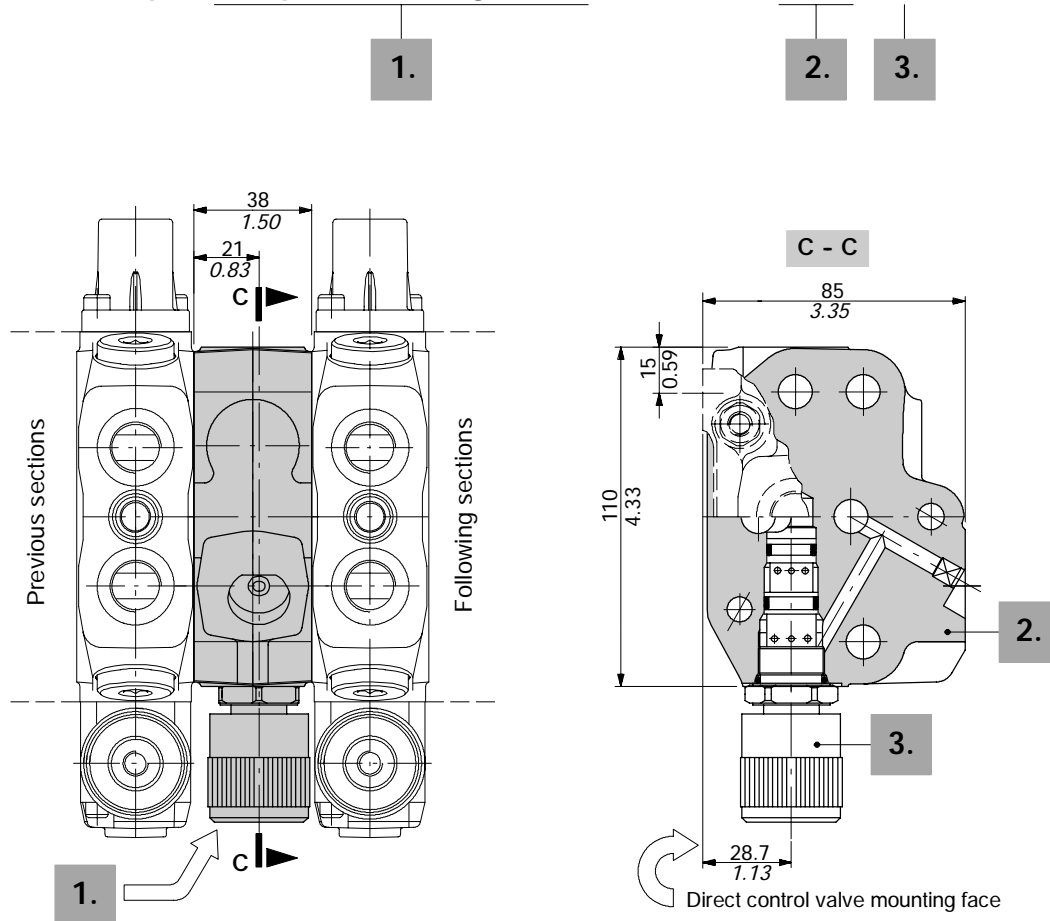

### Hydraulic circuit

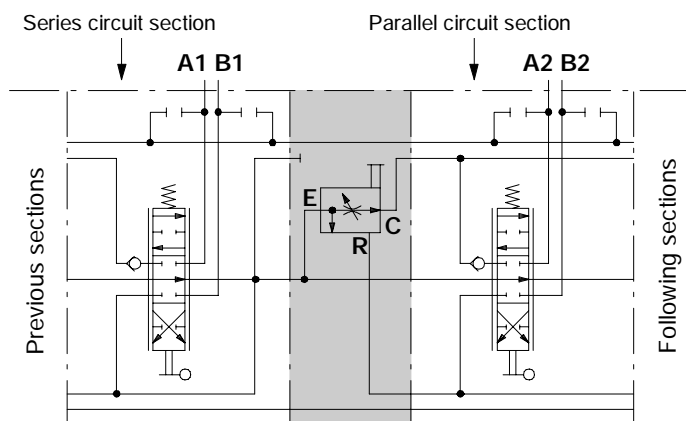

Description example:

SD6/4/AC(JG3-120)/.../S-18L/EVP91/18L/.../RC

### 1. Complete section

TYPE	CODE	DESCRIPTION
EVP91	612423503	Fine handwheel operated
EVP92	612423501	One turn with detent handwheel
EVP93	612423502	With 12VDC proportional solenoid valve

### 2. Section body kit

TYPE	CODE	DESCRIPTION
EVP9	5EL4060302	Include body and seals

### 3. Flow control valve

TYPE	CODE	DESCRIPTION
1	2S0PP10002000	Fine handwheel operated valve
2	2S1636020206	Valve with one turn with detent handwheel
3	2S0PP10002002	12VDC proportional solenoid valve

**EVP9 pressure compensated flow control section**

**Handwheel operated**

**Continuous fine regulation**

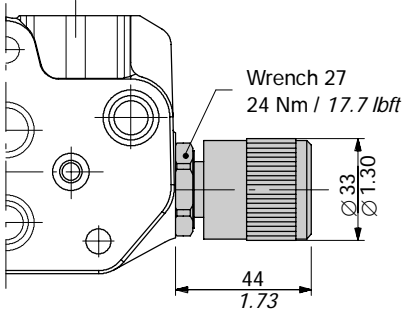

**One turn with detent**

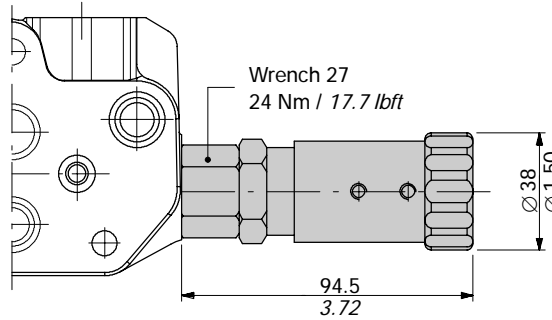

**Valve circuit**

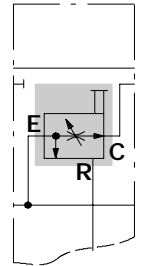

**With proportional solenoid control**

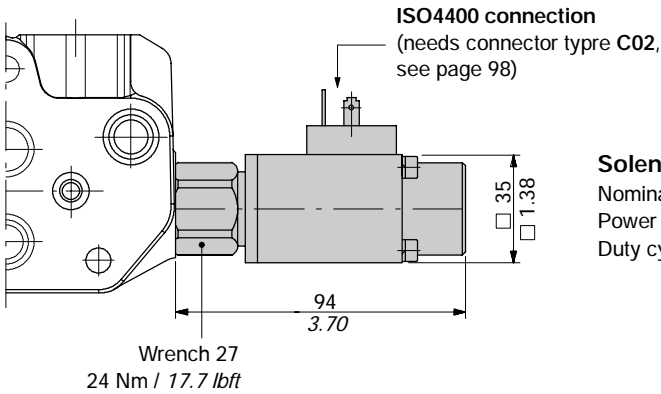

**Solenoid operating features**

Nominal voltage . . . : 12 VDC  
Power rating . . . . . : 28 W  
Duty cycle . . . . . : 100%

**Valve circuit**

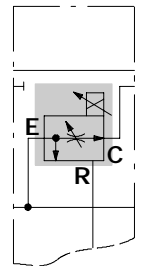

**Example of solenoid flow control valve connection**

It's show a configuration with push-button panel type UPA model UPA12/100/SC01B22: for information contact Sales Dept.

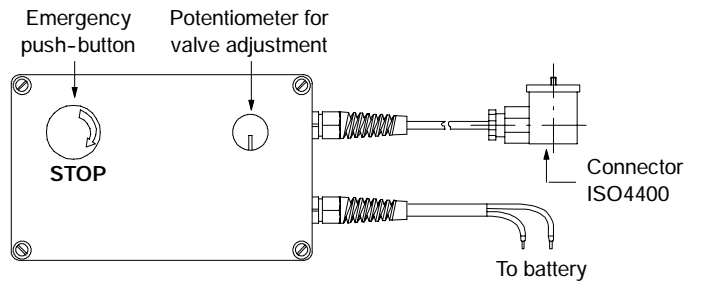

**Performance data**

**Pressure-flow diagram**

$Q_{in} = 45 \text{ l/min (12 US gpm)}$

1000 2000 3000 (psi)

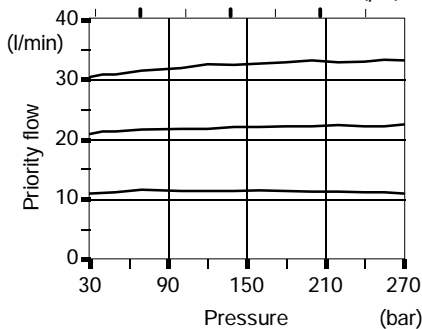

**Flow regulation diagram**

$Q_{in} = 45 \text{ l/min - P = 100 bar (1450 psi)}$

0 0.3 0.6 0.9 1.2 Current (A)

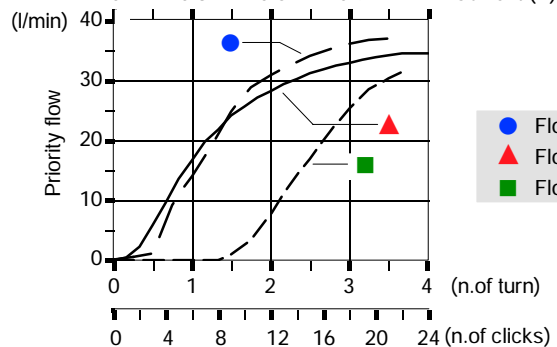

## Ordering codes

### Ordering example:

FS SD6 / RC \*



### Available configurations

RC: side outlet

RD: upper outlet

RE: upper outlet with side carry-over

RK: upper outlet and closed centre

See page 62.

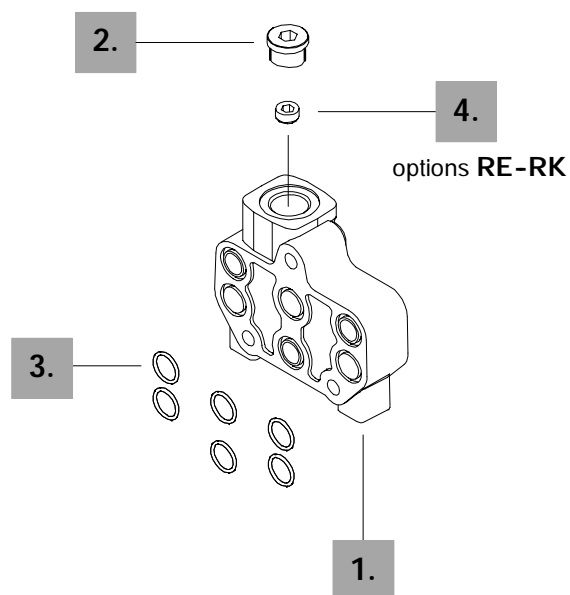

### Outlet section parts

Nr.	CODE	QTY	DESCRIPTION
1.	3FIA206300	1	Outlet cover body *
2.	3XTAP727180	1	G 1/2 plug *
3.	4GUA114018	6	14x1,78 NBR 70 SHO-ring seal

### Circuit options

Nr.	CODE	QTY	DESCRIPTION
4.	4TAP413210	1	G1/4 plug for carry-over (RE) and closed centre (RK) options

NOTE (\*) - Items are referred to *BSP* thread.

Dimensional data and hydraulic circuit

Type RC

Allen wrench 6 - 24 Nm / 17.7 lbf

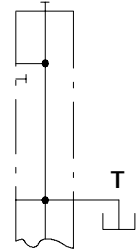
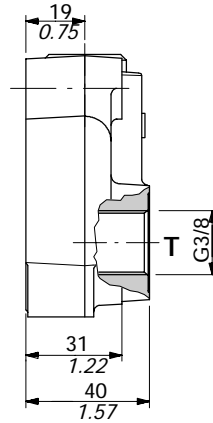
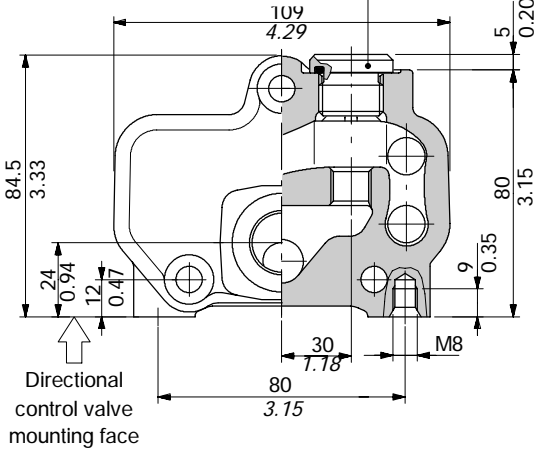

Type RD

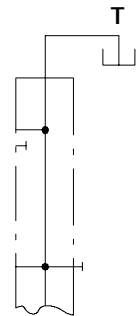
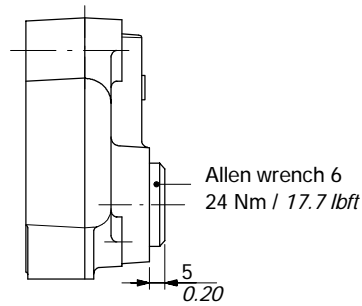
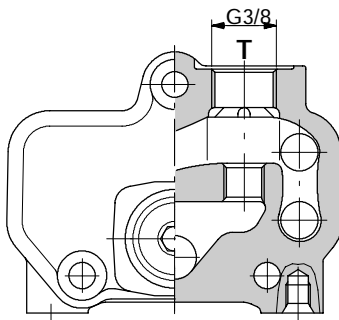

Type RE

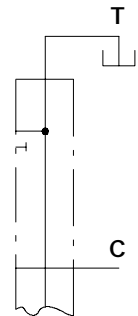
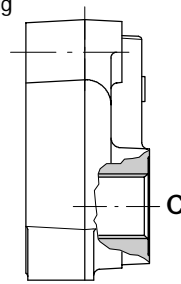
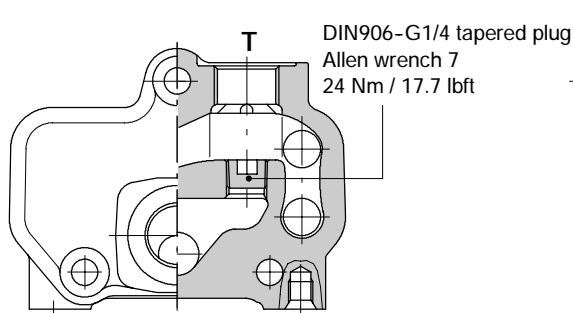

Type RK

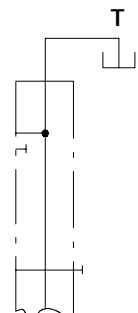
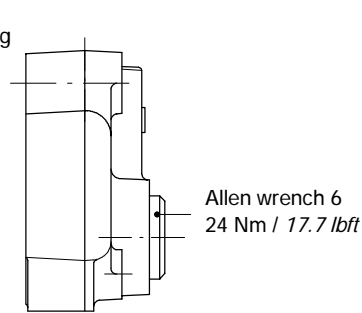
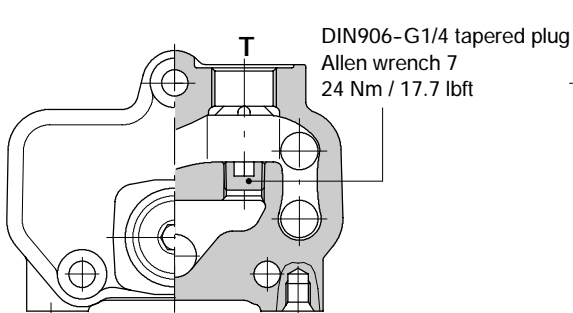



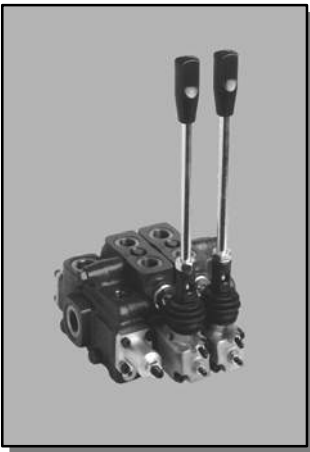

**Content**

Dimensional data ..... 74  
Hydraulic circuit ..... 75  
Performance data ..... 76  
Ordering codes ..... 77  
Inlet and outlet cover  
    ordering codes ..... 78  
    dimensional data and hydraulic circuit ..... 79  
Working section  
    ordering codes ..... 79  
    dimensional data and hydraulic circuit ..... 82  
    spools ..... 83  
    “A” side spool positions ..... 85  
    “B” side options ..... 87  
    complete controls ..... 90  
    port valves ..... 59  
Return cover ..... 93

## Dimensional data (with inlet flow control valve)

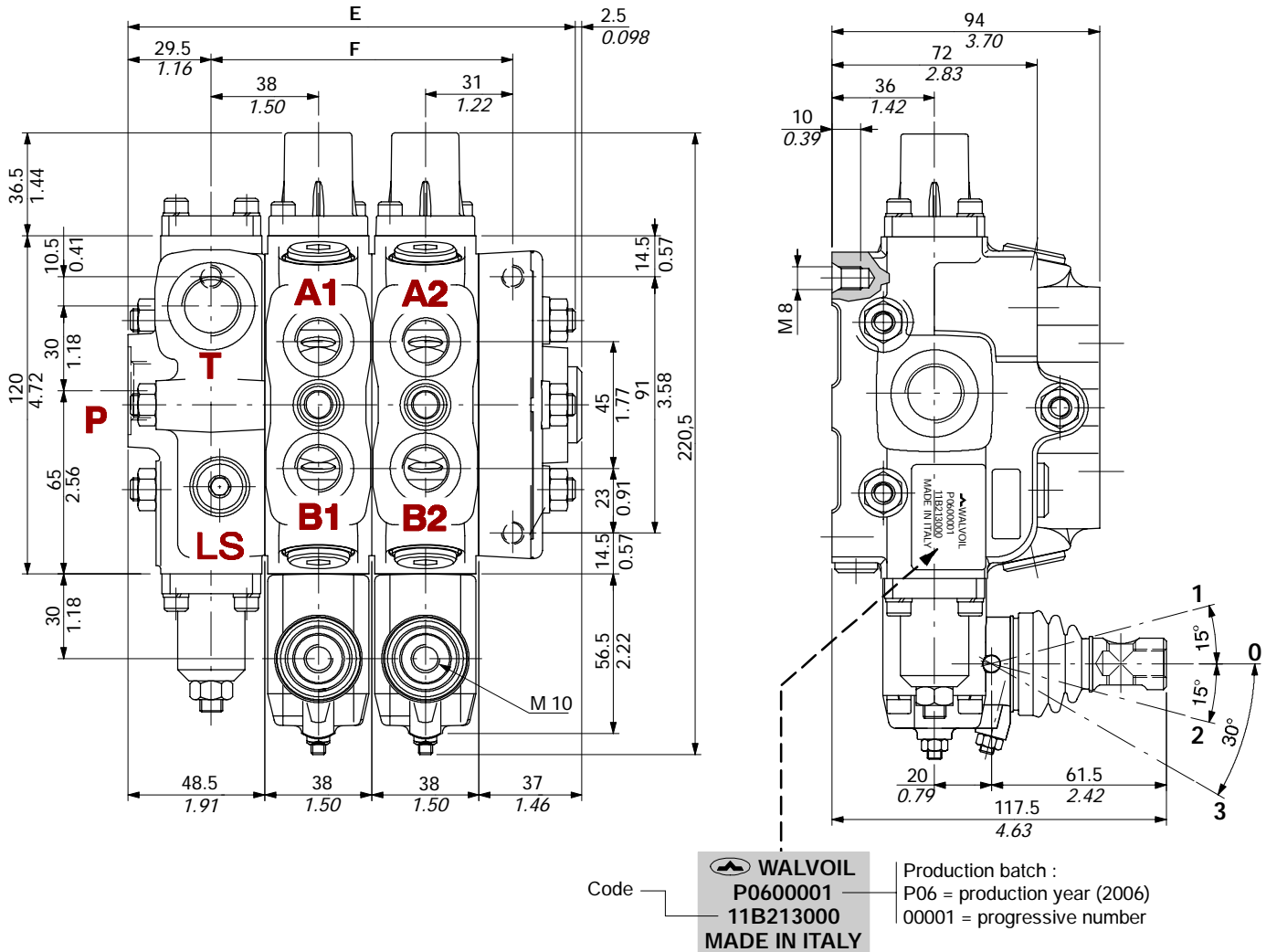

TYPE	E		F		Weight	
	mm	in	mm	in	kg	lb
DLS7/1	121	4.76	69	2.72	6.4	14.1
DLS7/2	159	6.26	107	4.21	8.9	19.6
DLS7/3	197	7.76	145	5.71	11.5	24.4
DLS7/4	235	9.25	183	7.2	14	30.9
DLS7/5	273	10.74	221	8.7	16.6	36.6

TYPE	E		F		Weight	
	mm	in	mm	in	kg	lb
DLS7/6	311	12.24	259	10.2	19.1	42.1
DLS7/7	349	13.74	297	11.7	21.7	47.8
DLS7/8	387	15.24	335	13.2	24.3	53.5
DLS7/9	425	16.73	373	14.7	26.9	59.2
DLS7/10	463	18.23	411	16.2	29.5	64.9

**Hydraulic circuit**

**Fixed displacement pump (open centre)**

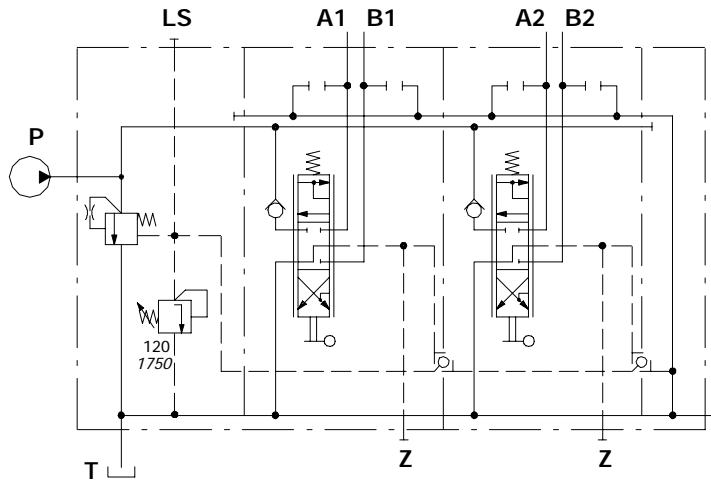

Description example:  
DLS7/2/AM(G3-120)/6S8MCLFG/6S8MCLFG/RF

**Variable displacement pump with load-sensing compensator (closed centre)**

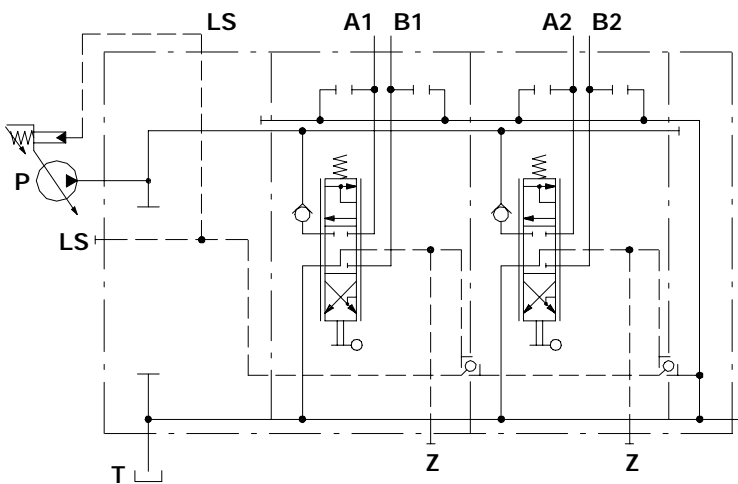

Description example:  
DLS7/2/AP(SV)/6S8MCLFG/6S8MCLFG/RF

Configuration with L.S. relief valve is also available.

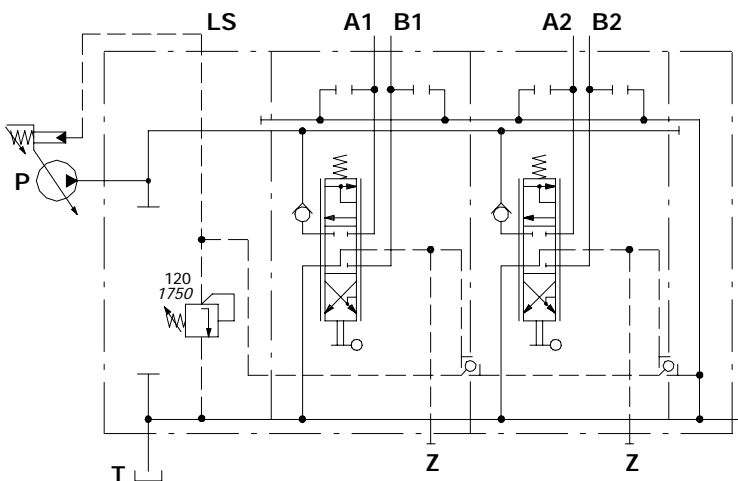

Description example:  
DLS7/2/AN(G3-120)/6S8MCLFG/6S8MCLFG/RF

**Performance data (pressure drop vs. flow)**

**Open centre**

From inlet to outlet.

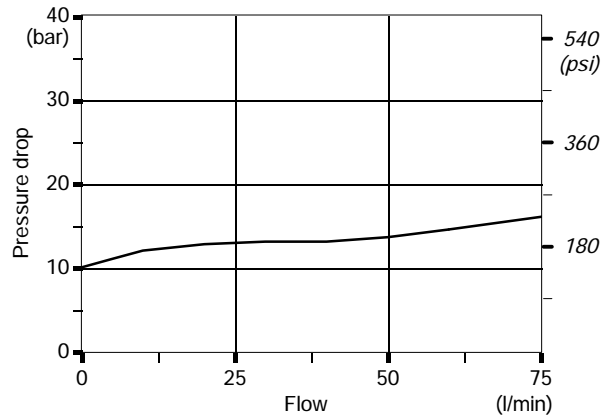
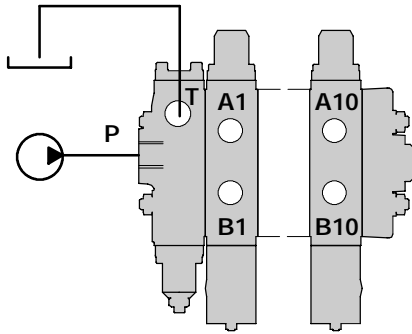

**Inlet to work port**

From inlet to A port (spool in position 1) or B port (spool in position 2).

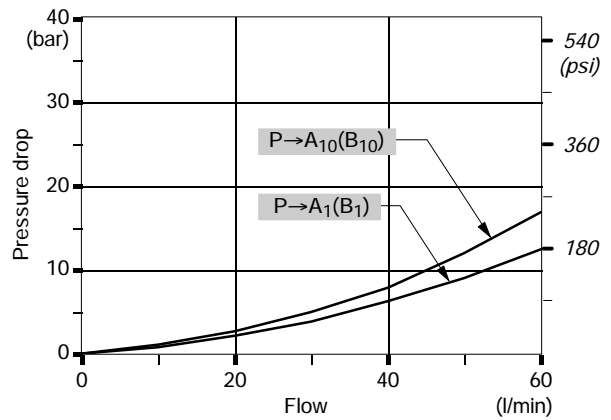
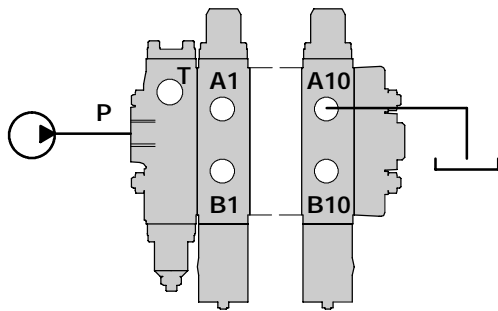

**Work port to outlet**

From A port (spool in position 2) or B port (spool in position 1) to outlet.

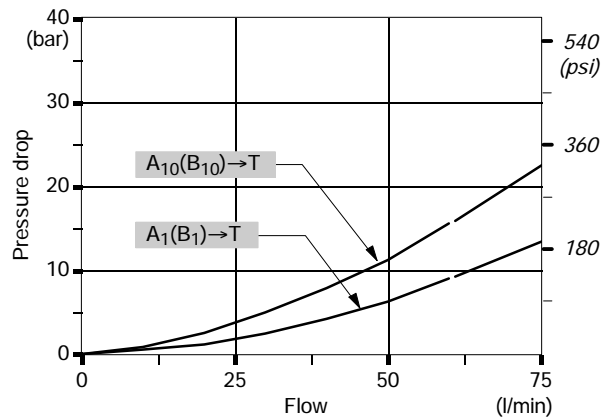
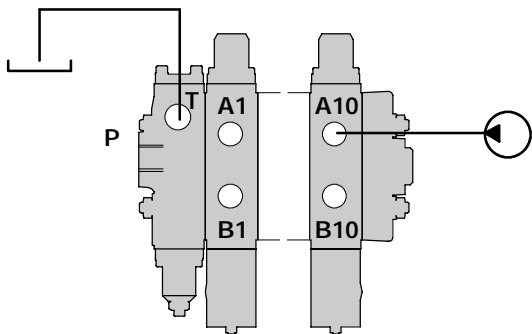

NOTE - Measured with spool type 6S.

Description example of standard configuration:

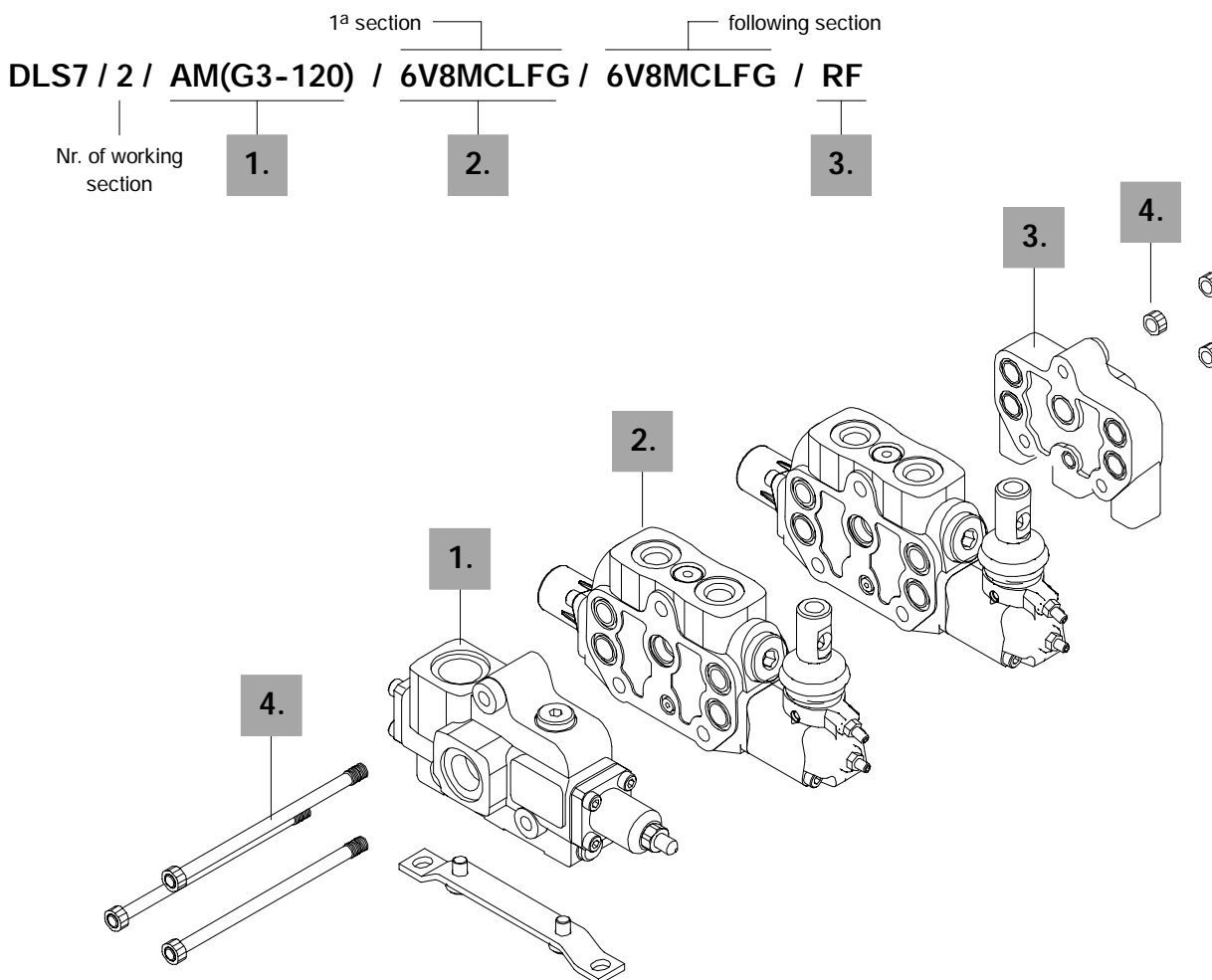

**1. Complete inlet / outlet cover \* page 78**

TYPE	CODE	DESCRIPTION
AM(G3-125)	61B331000	With flow control valve and L.S. overpressure relief valve
AP(SV)	61B333000	Without flow control valve and L.S. overpressure relief valve
AN(G3-125)	61B332000	Without flow control valve, with L.S. overpressure relief valve

**2. Complete working section \* page 80**

TYPE	CODE	DESCRIPTION
6V8MCLFG	61B131201	Parallel circuit, double acting spool with spring return, lever control
6V8IMF3	61B131221	Parallel circuit, double acting spool, proportional hydraulic control with spool stroke adjusting

NOTE (\*) - Items are referred to **BSP** thread.

**3. Return cover \* page 93**

TYPE	CODE	DESCRIPTION
RF	61B431000	Standard type
RH	61B433001	With L.S. signal carry-over

**4. Assembling kit**

CODE	DESCRIPTION
5TIR108126	tie rods with nuts for 1 sections
5TIR108166	tie rods with nuts for 2 sections
5TIR108204	tie rods with nuts for 3 sections
5TIR108242	tie rods with nuts for 4 sections
5TIR108280	tie rods with nuts for 5 sections
5TIR108318	tie rods with nuts for 6 sections
5TIR108356	tie rods with nuts for 7 sections
5TIR108394	tie rods with nuts for 8 sections
5TIR108432	tie rods with nuts for 9 sections
5TIR108470	tie rods with nuts for 10 sections
5TIR108508	tie rods with nuts for 11 sections
5TIR108546	tie rods with nuts for 12 sections

Ordering codes

Description example:

FE DLS7 / A M (G3 - 120)

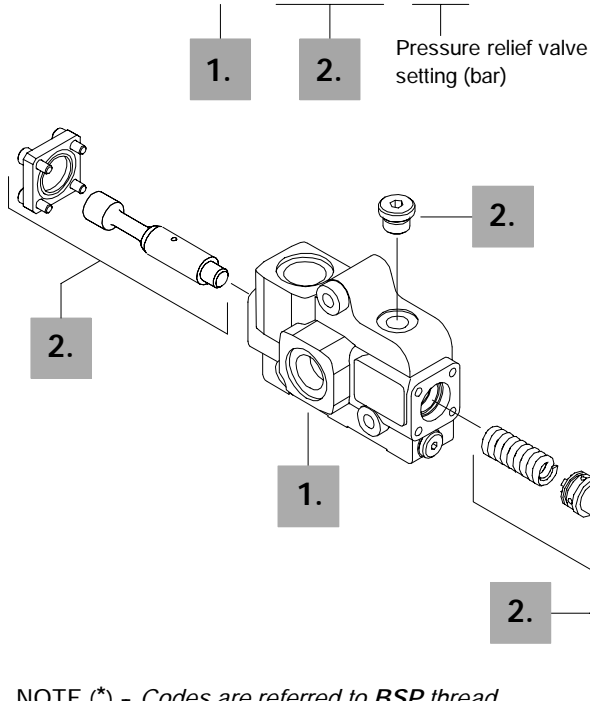

1. Cover body kit \*

CODE	DESCRIPTION
5FIA307320	A standard type

2. Inlet options

page 79

On Load-sensing signal

TIPO	CODICE	DESCRIZIONE
M(G3)	5KIT007300*	Compensator kit with overpressure valve (from 80 to 315 bar / 1150 to 4600 psi, standard setting 120 bar / 1750 psi)
P(SV)	5KIT007320	Compensator and overpressure valve blanking kit
N(G3)	5KIT007310	Compensator blanking kit with overpressure valve (from 80 to 315 bar / 1150 to 4600 psi, standard setting 120 bar / 1750 psi)

NOTE (\*) - Codes are referred to BSP thread.

Dimensional data and hydraulic circuit

It's shown an AM inlet and outlet cover.

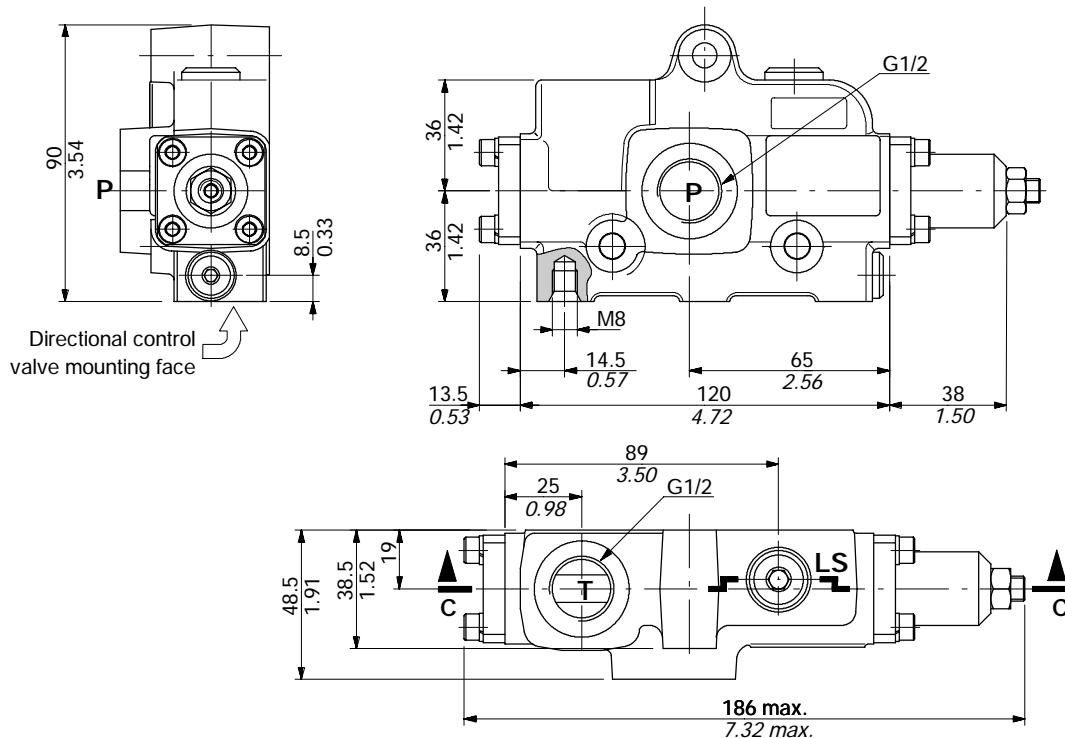

**Dimensional data and hydraulic circuit**

**Type AM with flow control valve and L.S. overpressure relief valve**

For systems with fixed displacement pumps (open centre version); see page 75.

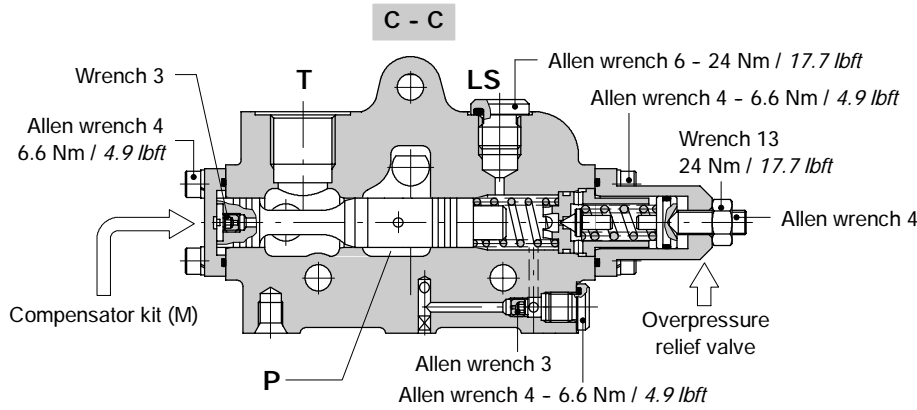

**Hydraulic circuit**

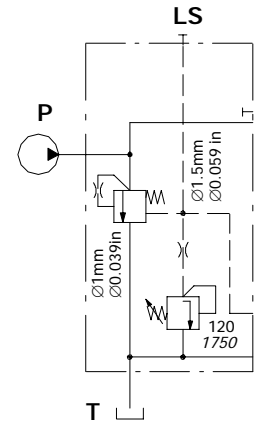

**Type AP without flow control valve and L.S. overpressure relief valve**

For systems with variable displacement pumps (closed centre version); see page 75.

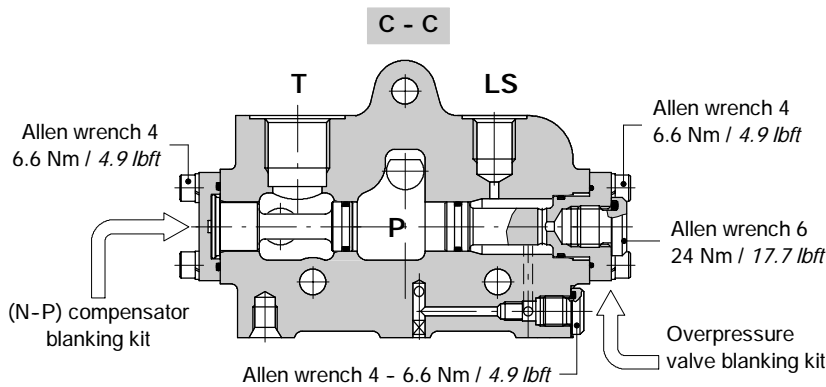

**Hydraulic circuit**

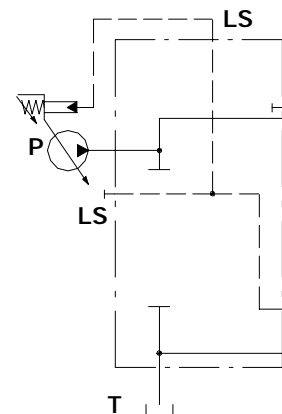

**Type AN without flow control valve, with L.S. overpressure relief valve**

For systems with variable displacement pumps (closed centre version); see page 75.

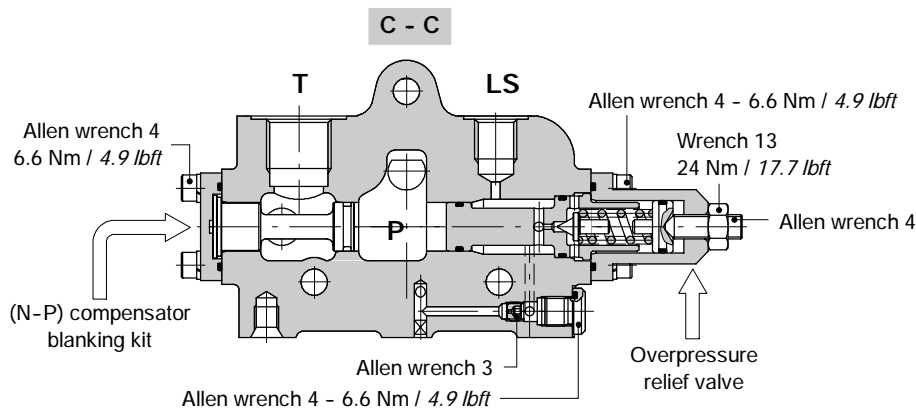

**Hydraulic circuit**

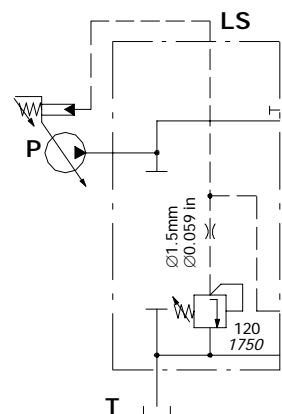

Ordering codes

Description example:

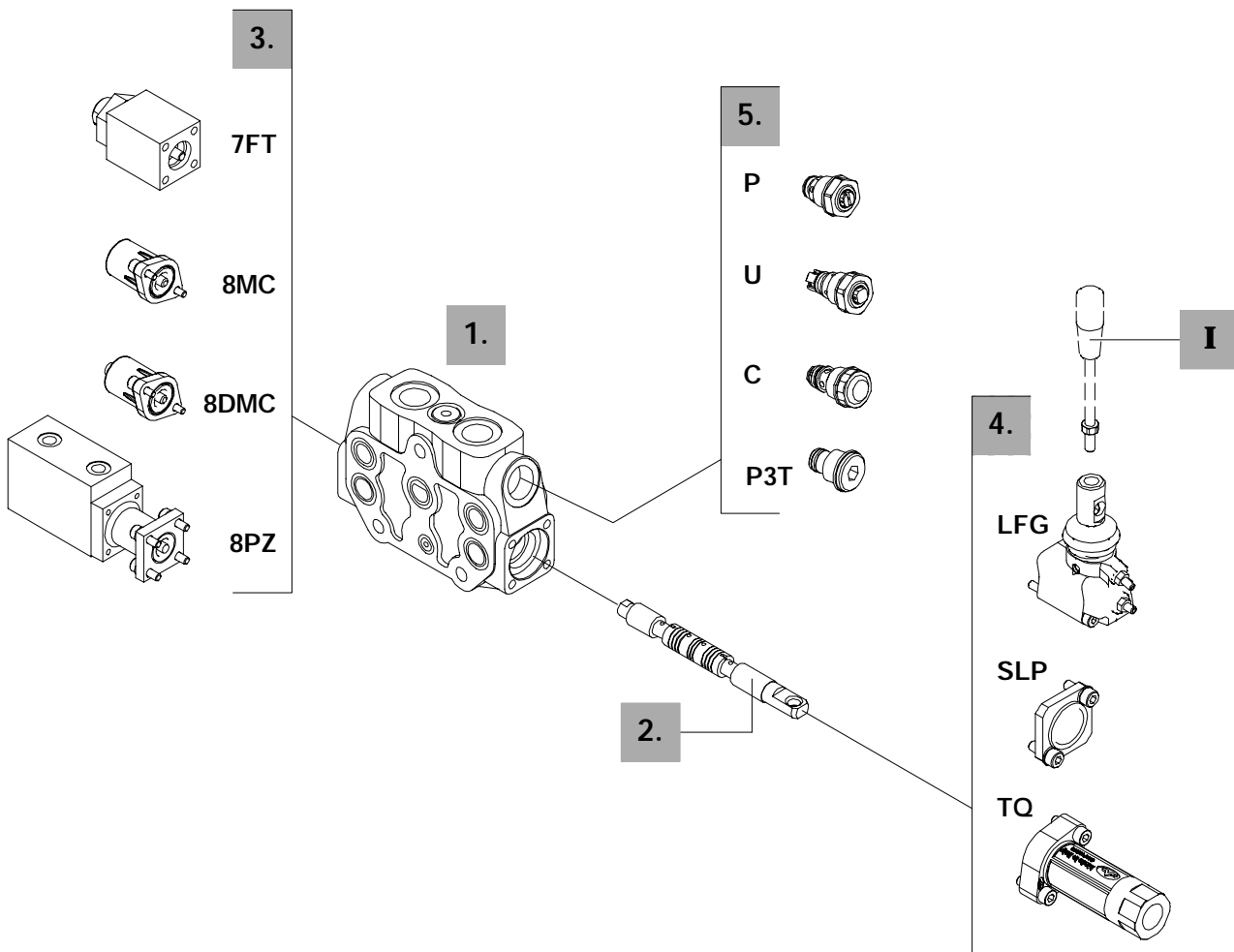
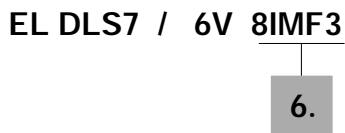
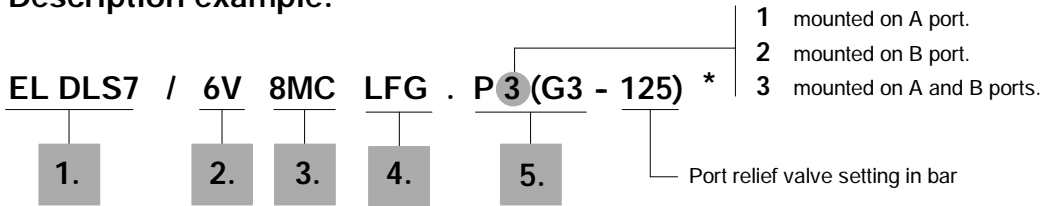

### 1. Working section kits \* page 82

TYPE	CODE	DESCRIPTION
-	5EL5073000	Parallel circuit with port valves prearrangement

Include body, seals, rings and load check valve.

### 2. Spools page 83

TYPE	CODE						DESCRIPTION
	10 l/min	20 l/min	30 l/min	40 l/min	50 l/min	60 l/min	
	D	V	T	Q	C	S	Nominal flow with 14 bar / 203 psi stand-by
6	3CU3110010	3CU3110020	3CU3110030	3CU3110040	3CU3110050	3CU3110060	Double acting, 3 position, with A and B closed in neutral position
7	3CU3125010	3CU3125020	3CU3125030	3CU3125040	3CU3125050	3CU3125060	Double acting, 3 position, with A and B to tank in neutral position

### 3. "A" side spool positioners page 85

TYPE	CODE	DESCRIPTION
7FT	5V07405000	With friction
8MC	5V08205000	With spring return in neutral position
8DMC	5V08205200	As type 8 and pin with M8 female thread for dual control
8PZ	5V08105709	Proportional pneumatic kit
8IZ	5V08106800	Proportional hydraulic kit

### 4. "B" side options page 87

TYPE	CODE	DESCRIPTION
LFG	5LEV107800	Zama (zic alloy) lever with with adjustable flow limiters
SL	-	Without leve box
SLP	5COP107000	Without lever box, with dust-proof plate
SLCZ	5COP205030	Without lever box, with endcap.
TQ	5TEL107110	Flexible cable connection; for CD cables
LCB	5CLO202000	Joystick lever for 2 sections operation

### 6. Complete controls \* page 90

8IMF3 proportional hydraulic control kit with flow limiter.

#### I Optional handlevers

TYPE	CODE	DESCRIPTION
AL01/M10x150	170012015	For LFG lever box, L = 150mm / 5.91 in
AL08/M12x200	170013120	For LCB joystick, L = 200 mm / 7.87 in

### 5. Port valves page 59

TYPE	CODE	DESCRIPTION
<b>Assembled on section</b>		
P3T	XTAP524280	A and B ports valve blanking plugs
C	5KIT406100	Anti-cavitation
<u>Anti-shock valve</u>		
P(G2)	5KIT206112	From 50 to 125 bar / 725 to 1800 psi standard setting 63 bar / 900 psi
P(G3)	5KIT206113	From 100 to 200 bar / 1450 to 2900 psi standard setting 100 bar / 1450 psi
P(G4)	5KIT206114	From 160 to 315 bar / 2300 to 4600 psi standard setting 200 bar / 2900 psi
<u>Anti-shock and anti-cavitation valve</u>		
U(G2)	5KIT306112	From 50 to 125 bar / 725 to 1800 psi standard setting 63 bar / 900 psi
U(G3)	5KIT306113	From 100 to 250 bar / 1450 to 3600 psi standard setting 100 bar / 1800 psi
U(G4)	5KIT306114	From 160 to 315 bar / 2300 to 4600 psi standard setting 200 bar / 2900 psi

Standard setting is referred to 10 l/min flow.

#### Flange mounted type

BPT	XTAP627300	BP and BPS valves blanking plug
<u>Direct type</u>		
BP1	612002000*	Block with valve on port A
BP2	612002000*	Block with valve on port B
BP3	612002100*	Block with valves on ports A and B
BP	XCAR605110	Single valve
<u>With Pre-opening</u>		
BPS1	612003000*	Block with valve on port A
BPS2	612003000*	Block with valve on port B
BPS3	612003100*	Block with valves on ports A and B
BPS	XCAR605210	Single valve

NOTE (\*) - Items are referred to BSP thread.

**Dimensional data and hydraulic circuit**

Working section kit is fitted with body (1), washer (2), spool O-ring seals (3), load check valve (4), assembling O-ring seals (5), plug on L.S. signal (6) and ball on shuttle valve (7).

Working sections are supplied with port valve prearrangement.

Drawing shows a complete working section, type DLS7/P-7S8MCLFG.

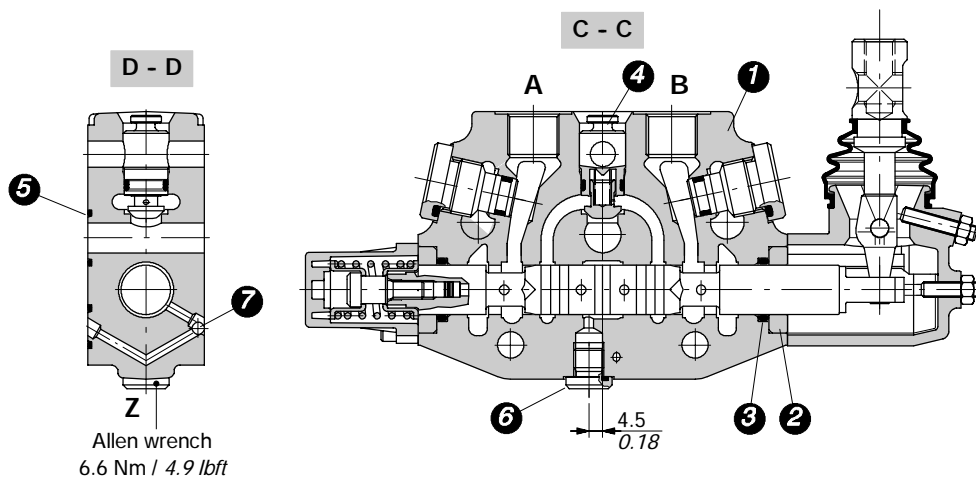
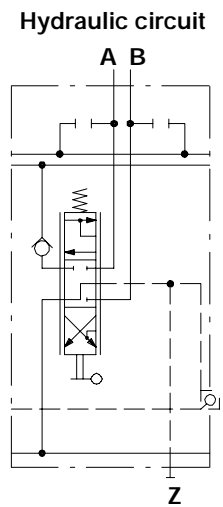
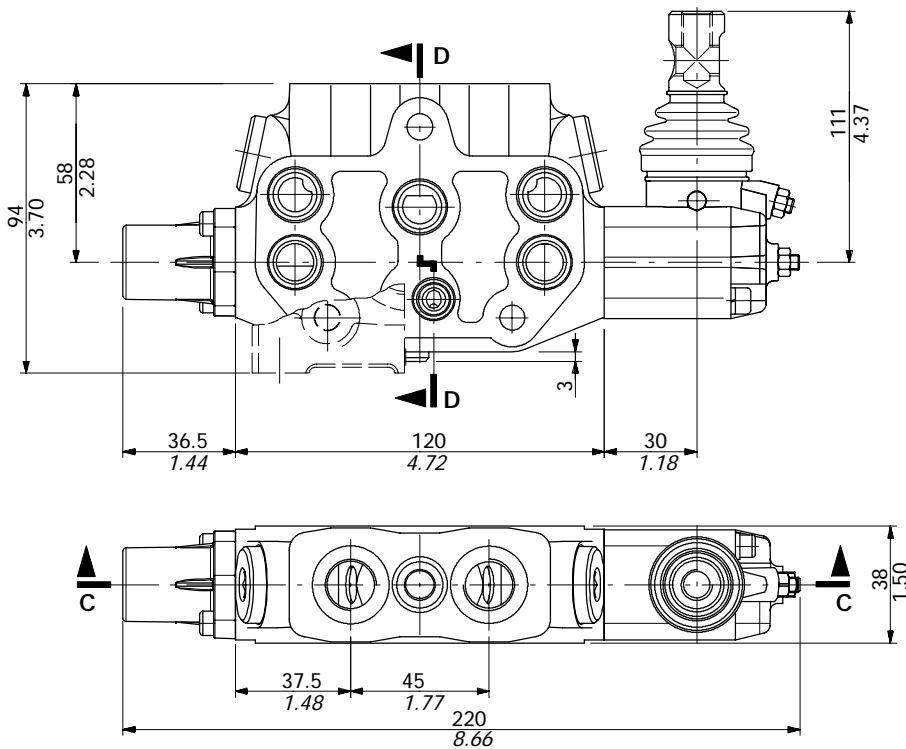

Allen wrench  
6.6 Nm / 4.9 lbf

Type 6S

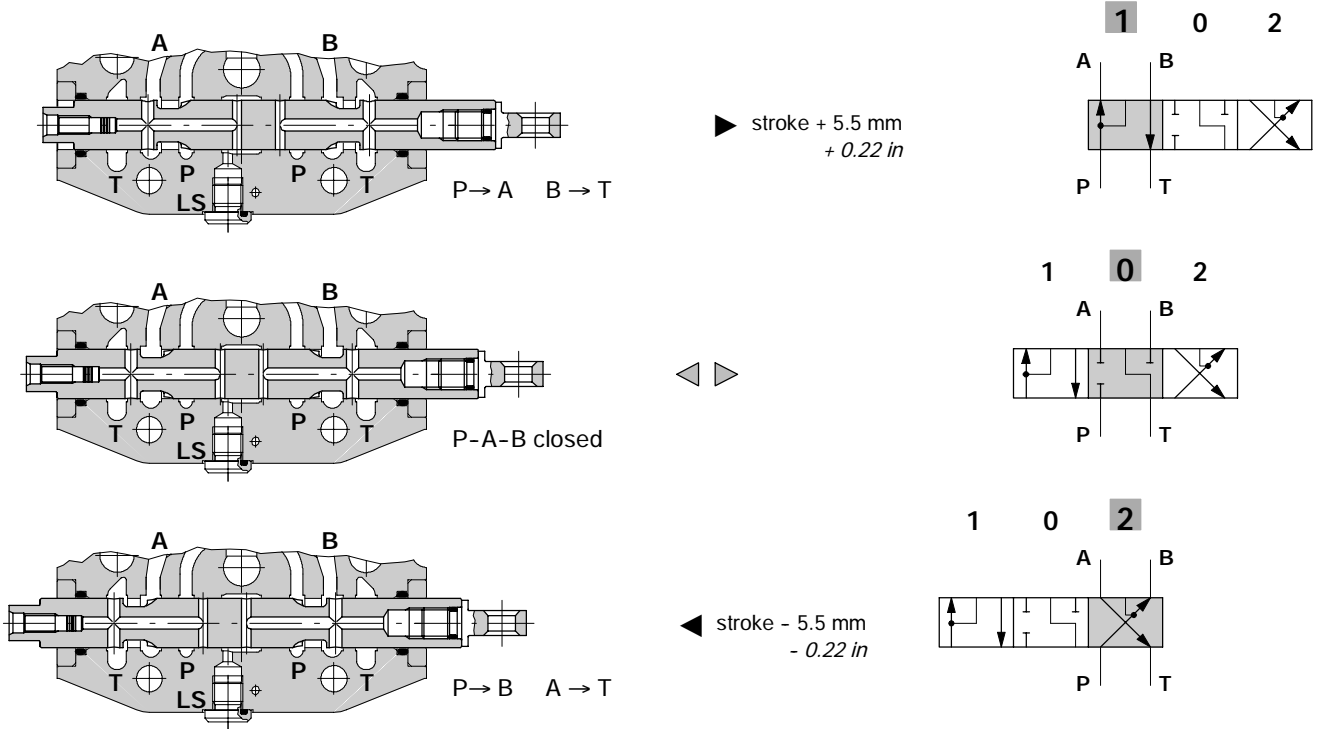

Type 7S

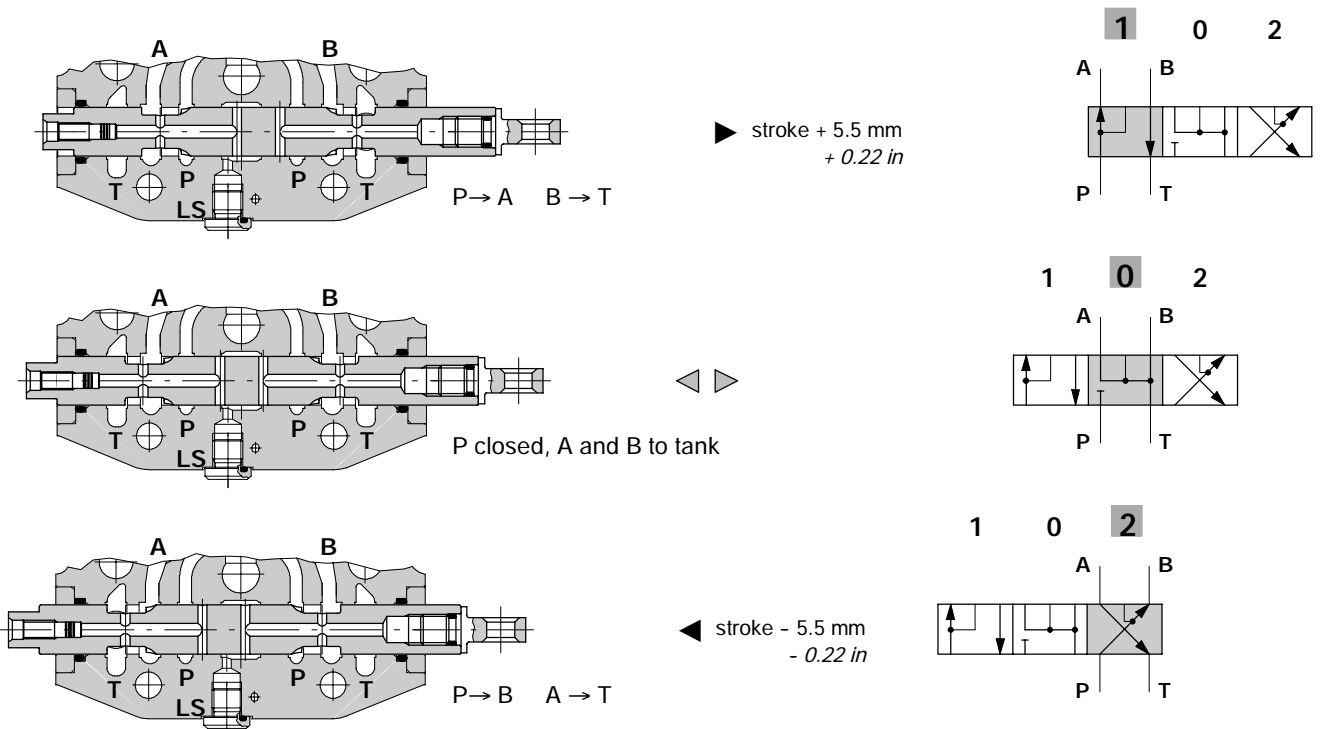

Spools

Spool metering with AM inlet cover and 14 bar / 203 psi standard stand-by

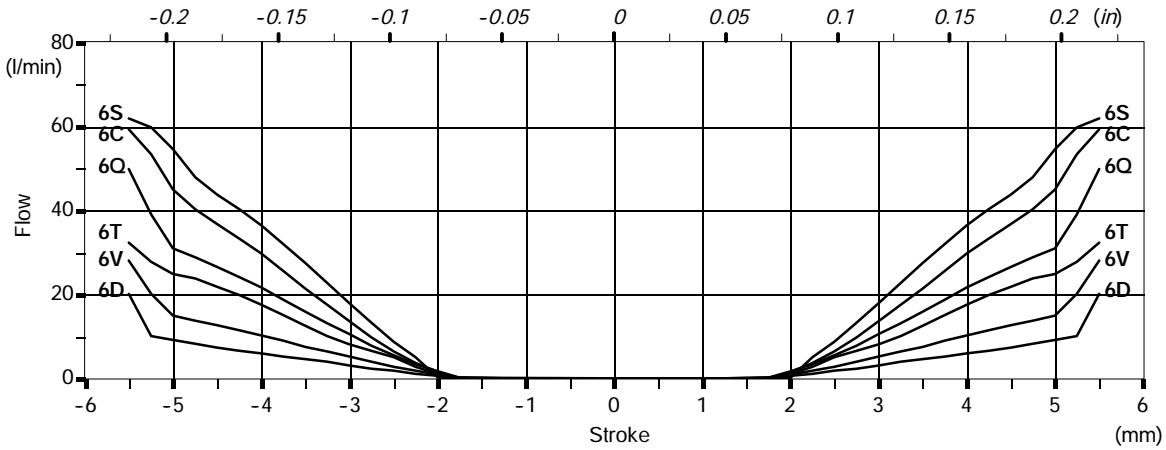

Spool metering with AN inlet cover

With 10 bar / 145 psi L.S. pump stand-by

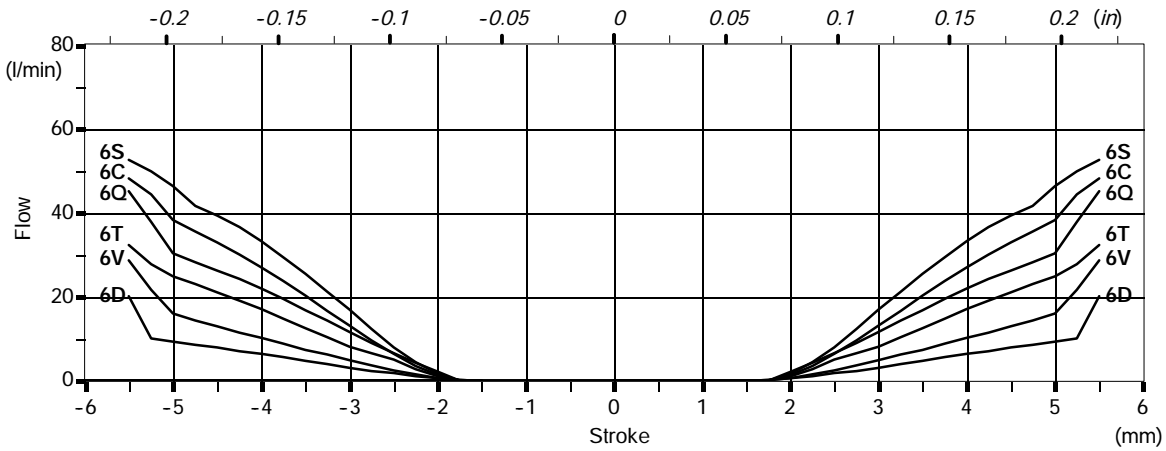

With 20 bar / 290 psi L.S. pump stand-by

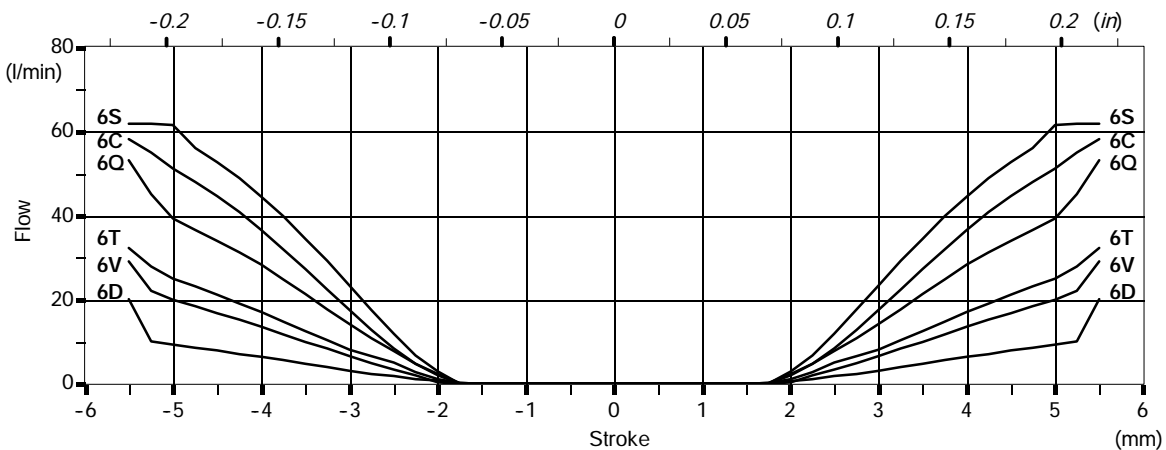

"A" side spool positioners

With friction type 7FT

Allen wrench 4 - 9.8 Nm / 7.2 lbf

Wrench 34  
24 Nm / 17.7 lbf

Allen wrench 4

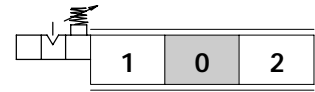
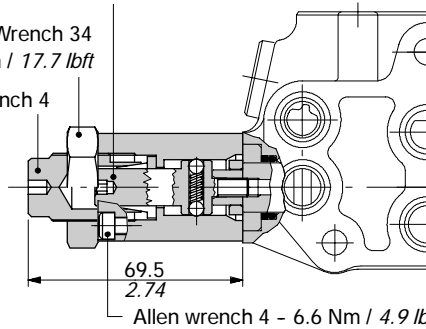

With spring return

8MC kit



Allen wrench 4  
6.6 Nm / 4.9 lbf

Allen wrench 5  
9.8 Nm / 7.2 lbf

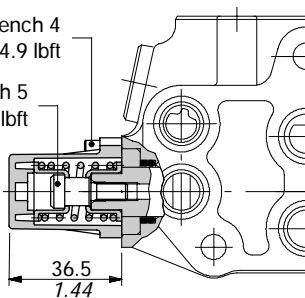

Force-stroke diagram

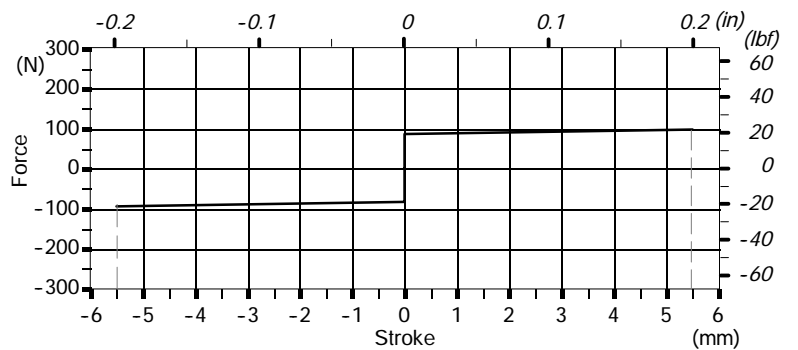

8DMC kit

Spool end joint code XPER315400 is available on request in order to screw onto pin.

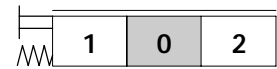

Allen wrench 4 - 6.6 Nm / 4.9 lbf

Wrench 9 - 9.8 Nm / 7.2 lbf

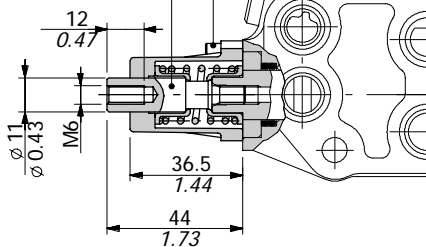

Spool end joint dimension

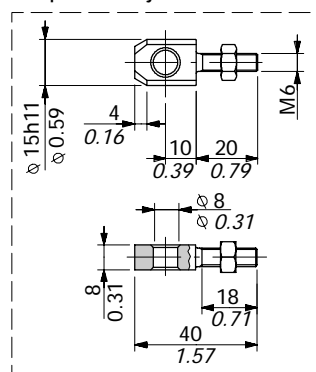

"A" side spool positioners

8PZ proportional pneumatic control

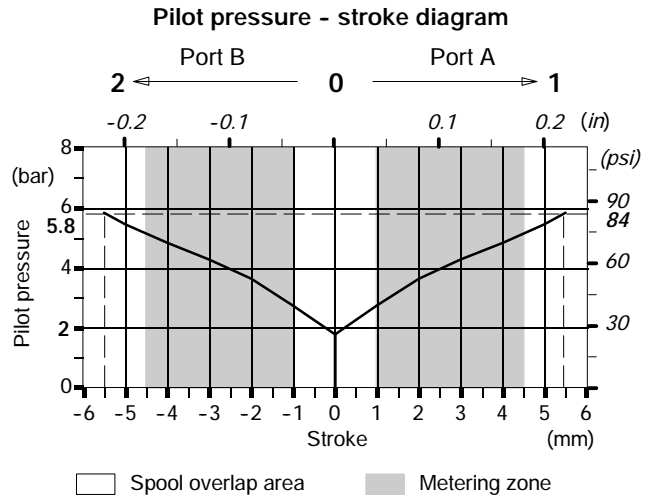
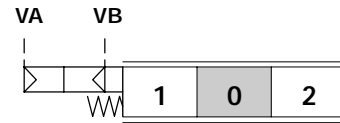
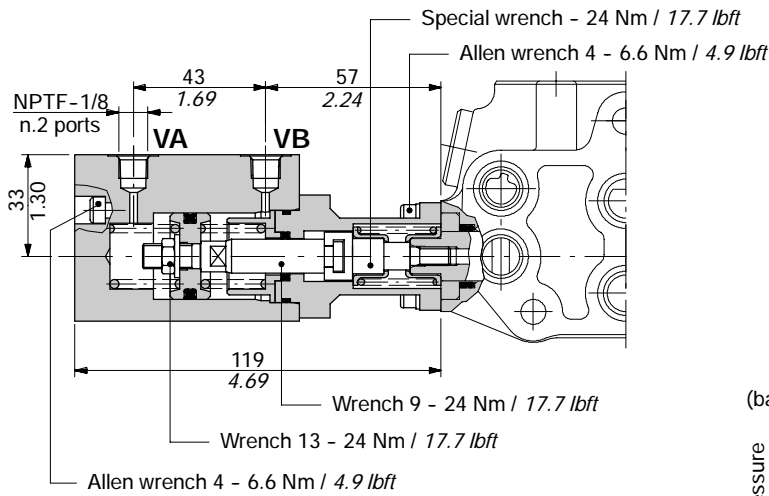

**Operating features**

Max. pilot pressure ..... : 10 bar / 145 psi

8IZ proportional hydraulic control

It can be used with body kit without seals and ring on spool (standard body) on side "A" code: 5EL507300B.

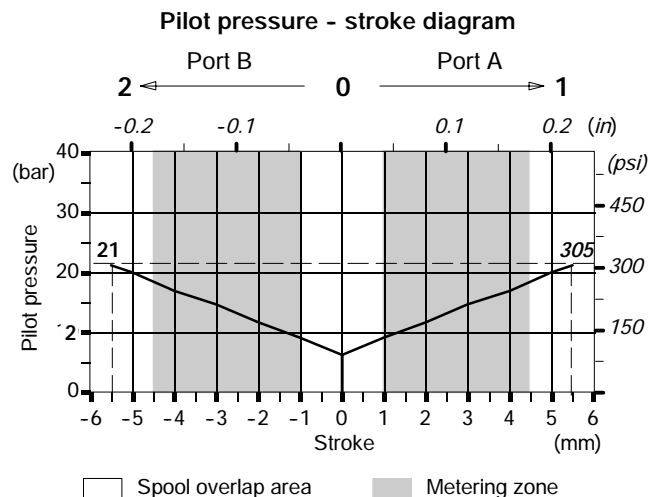
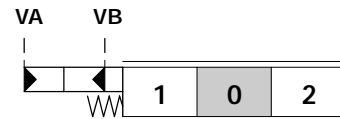
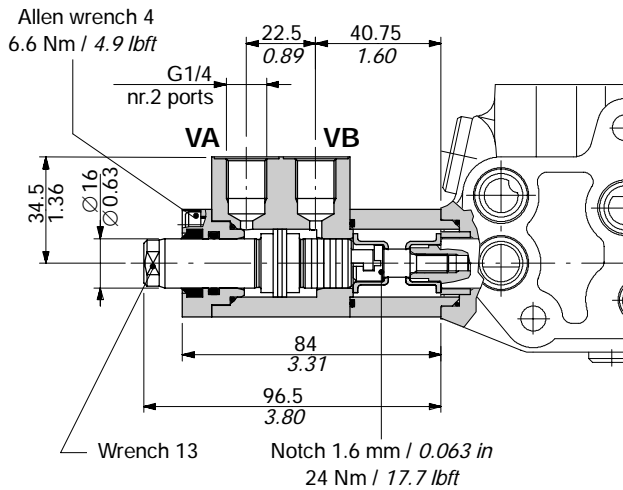

**Operating features**

Max. pilot pressure ..... : 50 bar / 725 psi

Lever controls

LFG type

Cast iron lever pivot box with protective rubber bellow; it's complete of two screws for spool stroke adjusting in both directions. It can be rotated 180° (configuration LFG180).

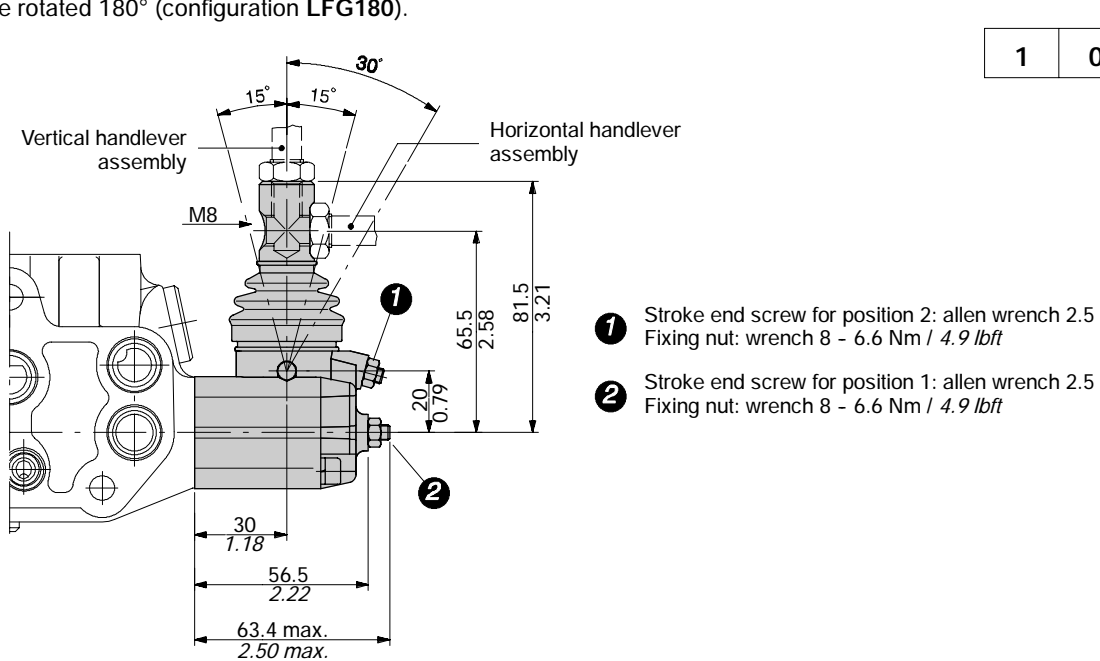

Controls prearrangement

SL type

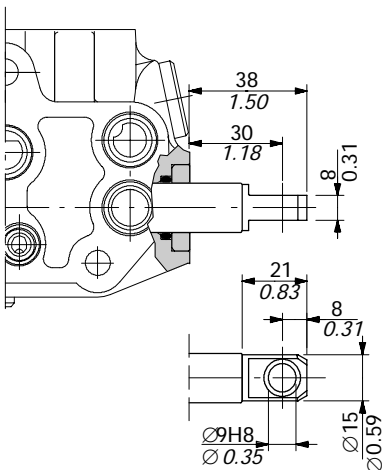
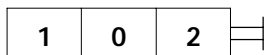

SLP type

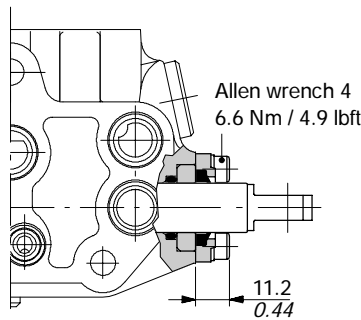
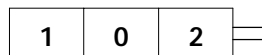

Mechanical control with dust-proof plate kit.

SLCZ type

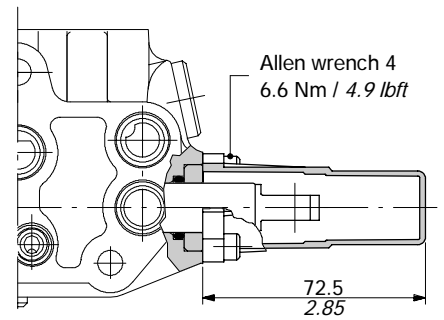
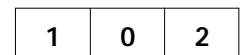

Protection cap usable with pneumatic 8P, electro-pneumatic 8EP3, and electro-hydraulic 8ED3 spool positioners.

**"B" side options**

**TQ cable remote control kit**

Waterproof cap prearranged for remote control with flexible cable.

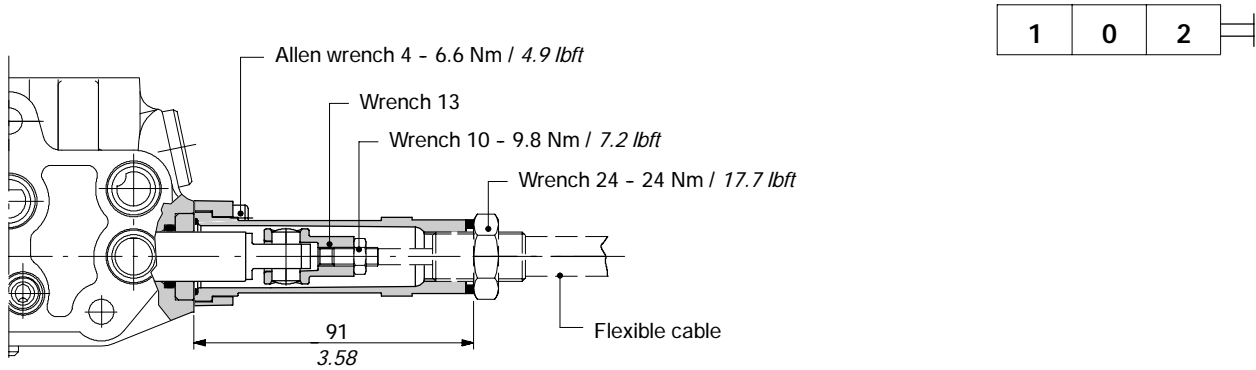

NOTE - For further information about remote cable control, require related documentation.

**Example of cable control**

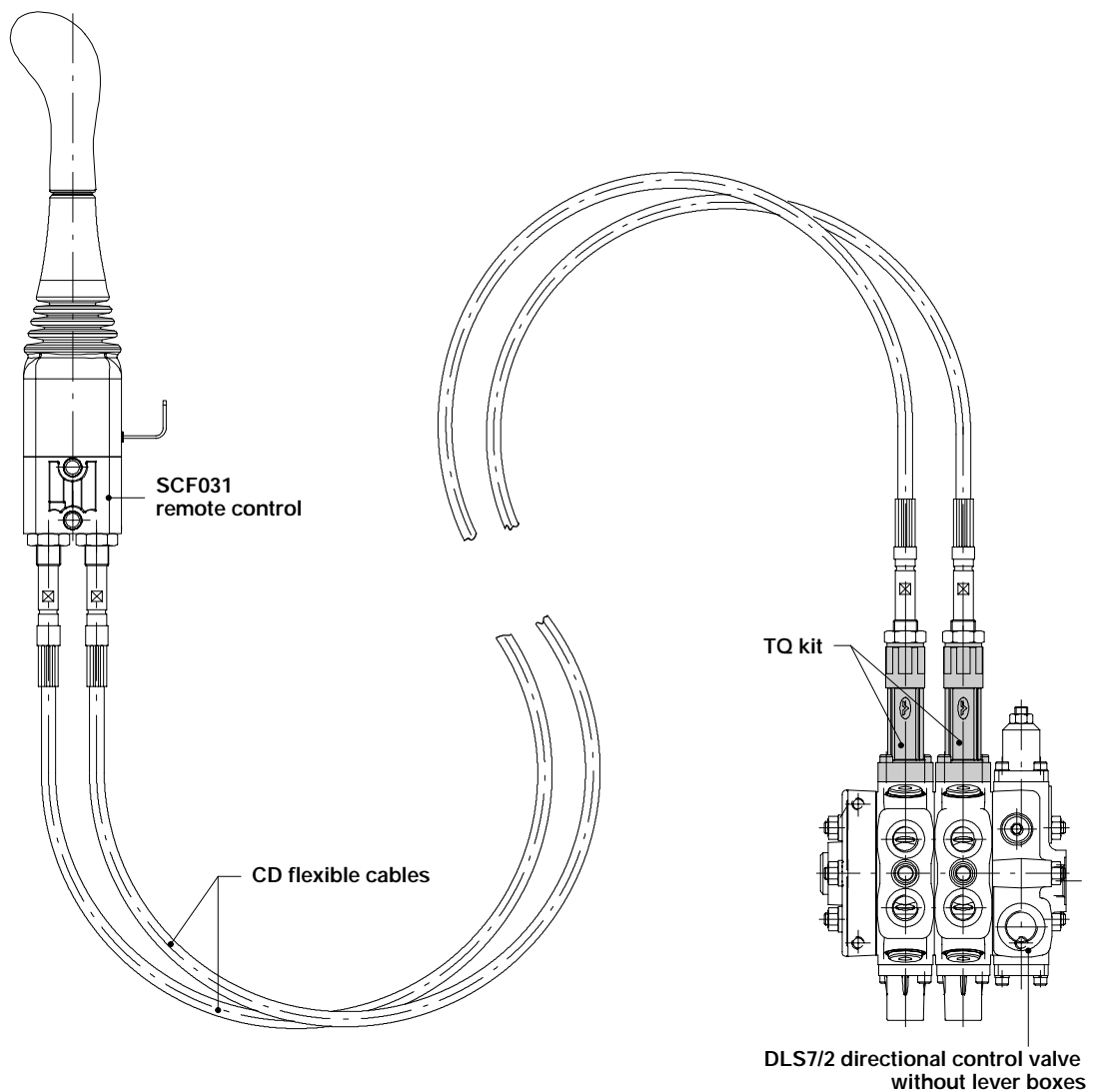

LCB joystick

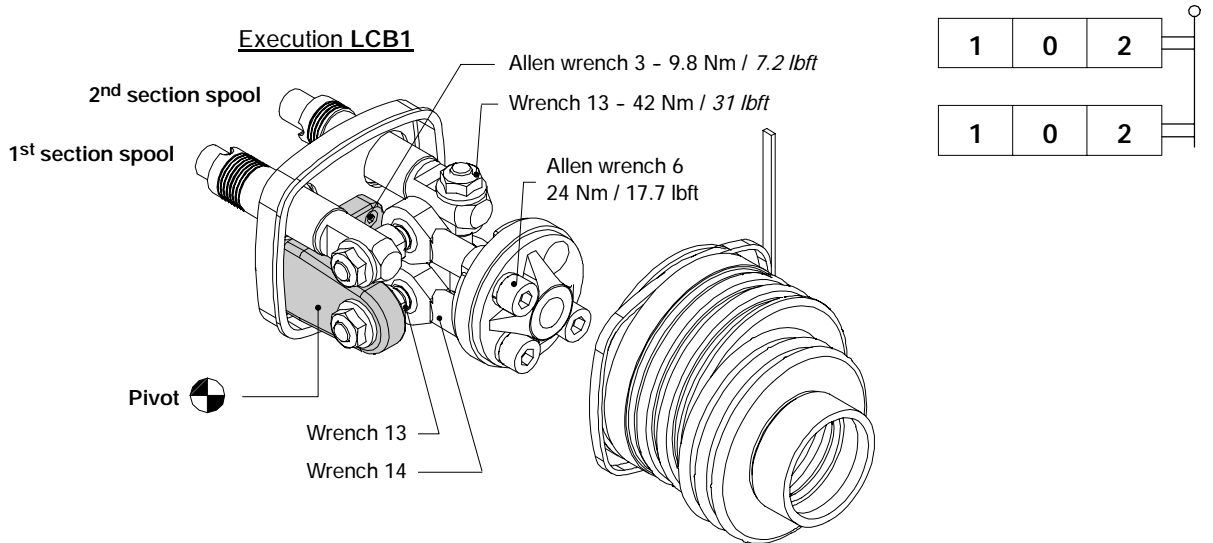

NOTE - The handlever must be ordered separately (see page 81).

Dimensions and movement scheme

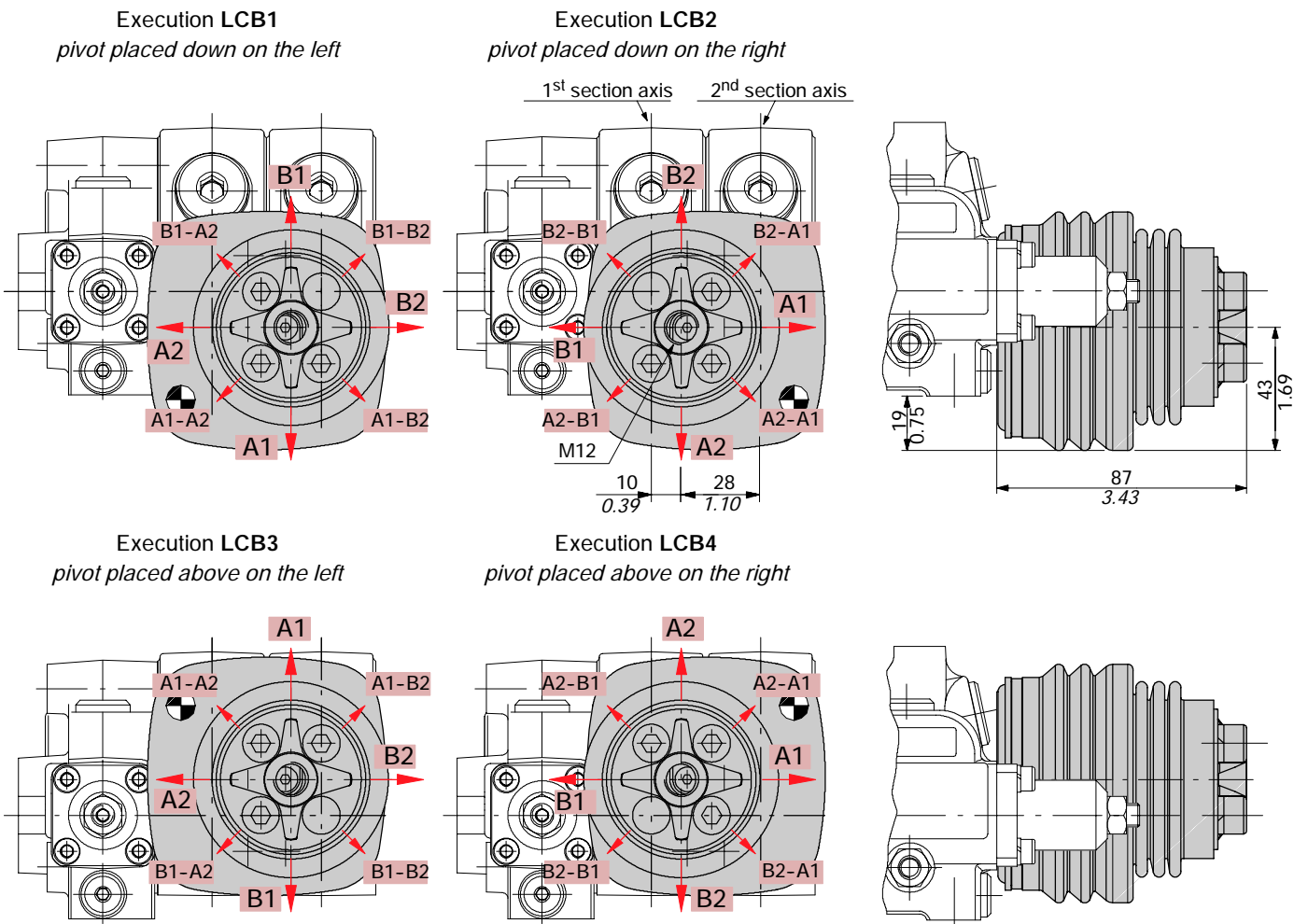

NOTE - Due to limited space in case of LCB3 or LCB4 configuration the assembly of ports service relief valves is not possible.

Complete controls

8ESF solenoid control

Solenoid direct control with spring return to neutral position; it needs special spools and working section body kit (without seals on spool); fitted with screws for spool stroke adjusting in both directions.

Description example:

EL DLS7 / P - 6V 8ES3F3 P1(G3 - 125) - 12VDC

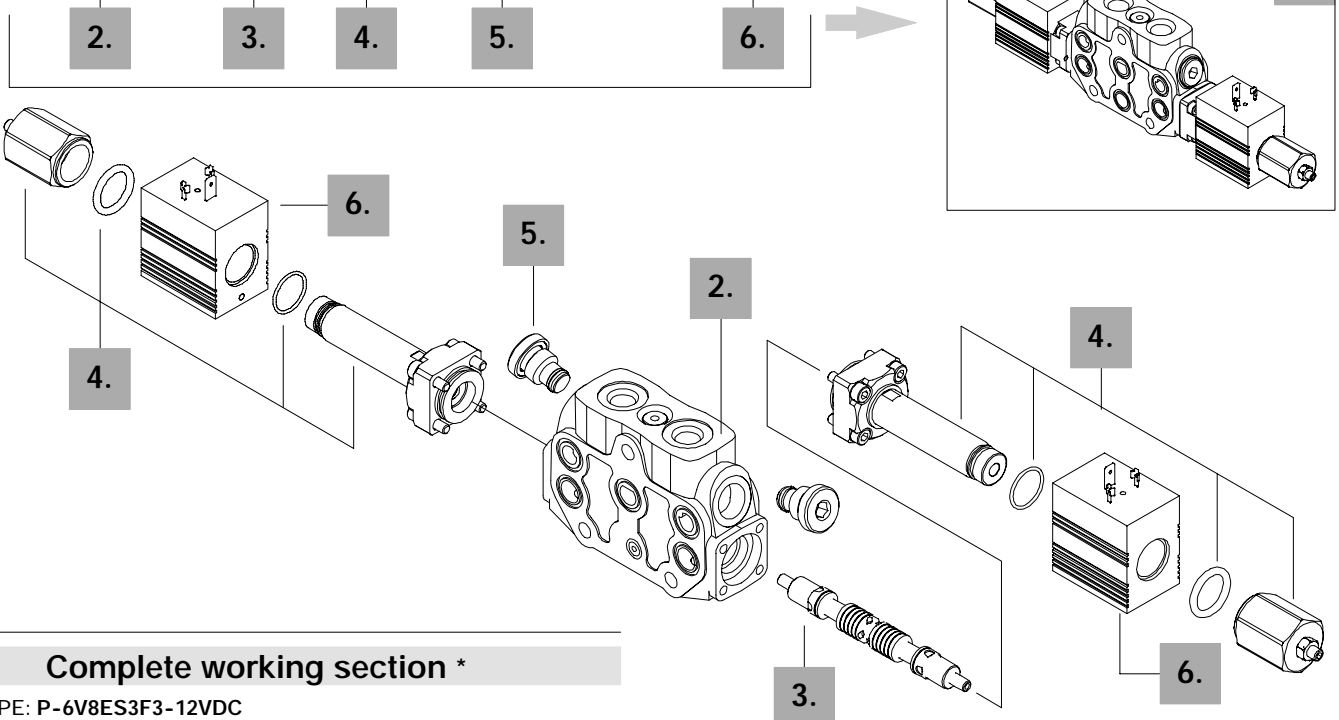

1. Complete working section \*

TYPE: P-6V8ES3F3-12VDC  
 CODE: 61B131000  
 DESCRIPTION: Parallel circuit, double acting spool, double acting ON/OFF solenoid control

2. Working section kit \*

TYPE	CODE	DESCRIPTION
P/ES	5EL5073800	Parallel circuit

NOTE (\*) - Codes are referred to **BSP** thread.

3. Spools

TYPE	CODICE			DESCRIPTION
	from 5 to 20 l/min	from 21 to 40 l/min	from 41 to 60 l/mi	
	V	Q	S	Nominal flow with 15 bar / 218 psi stand-by
6	3CU3110120	3CU3110140	3CU3110160	Double acting, 3 pos., with A and B closed in neutral pos.
7	3CU3125120	3CU3125140	3CU3125160	Double acting, 3 pos., with A and B to tank in neutral pos.

4. Control kit

TYPE	CODE	DESCRIPTION
8ES3F3	5CAN08021	Double acting with spring return to neutral position

5. Port valves

For codes please refer to page 81.

6. Coils

TYPE	CODE	DESCRIPTION
<u>With ISO4400 connector</u>		
10.5VDC	4SOL412011	Nominal voltage 10.5VDC
12VDC	4SOL412012	Nominal voltage 12VDC
24VDC	4SOL412024	Nominal voltage 24VDC
<u>With Deutsch series DT connector</u>		
4-10.5VDC	4SOL412111	Nominal voltage 10.5VDC
4-12VDC	4SOL412112	Nominal voltage 12VDC

8ESF solenoid control

Electric wiring example

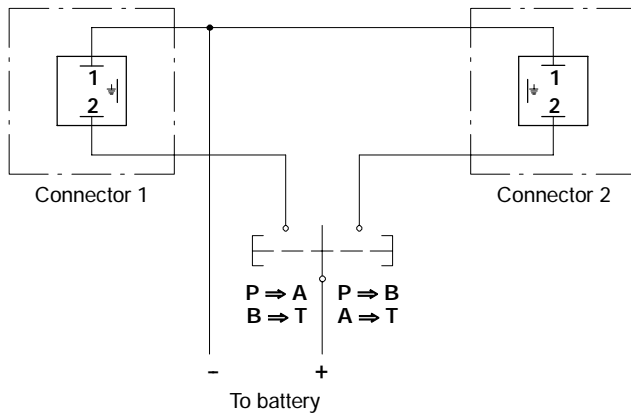

8ES3F3 kit  
double acting

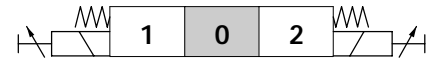

Operating features

CONTROL

Internal leakage A(B)→T

( $\Delta p = 100 \text{ bar} - 1450 \text{ psi} / T = 40^\circ\text{C}$ ) :  $15 \text{ cm}^3/\text{min} - 0.91 \text{ in}^3/\text{min}$

COIL

Nominal voltage tolerance :  $\pm 10\%$

Power rating :  $36 \text{ W}$

Coil insulation : class H

Duty cycle :  $100\%$

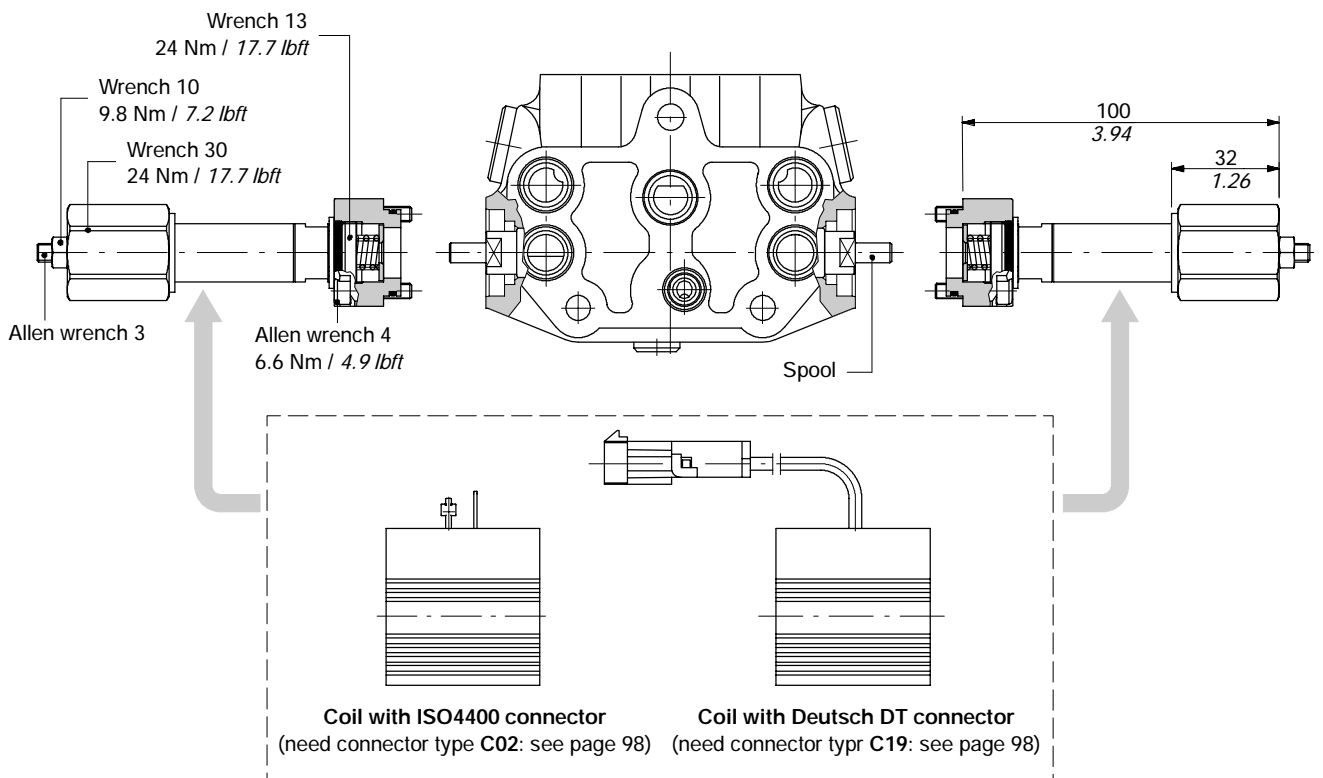

Complete controls

8IMF3 proportional hydraulic kit

With screws for spool stroke adjusting in both directions, code 5IDR207000.

It can be used with special spools and body kit without seals and ring on spool (standard body) code: 5EL507300A.

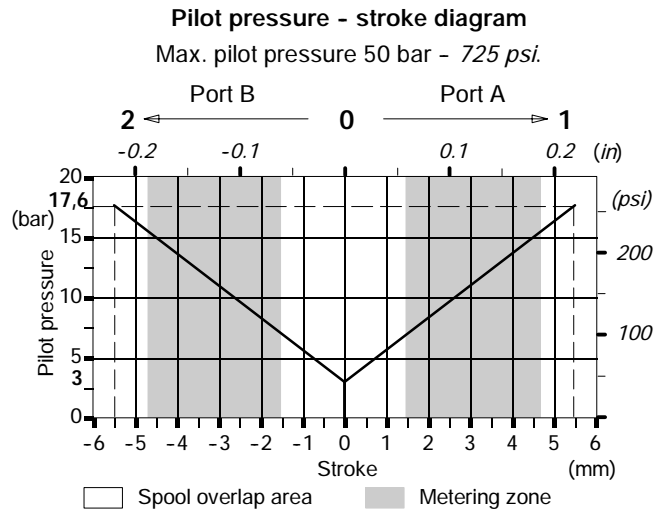
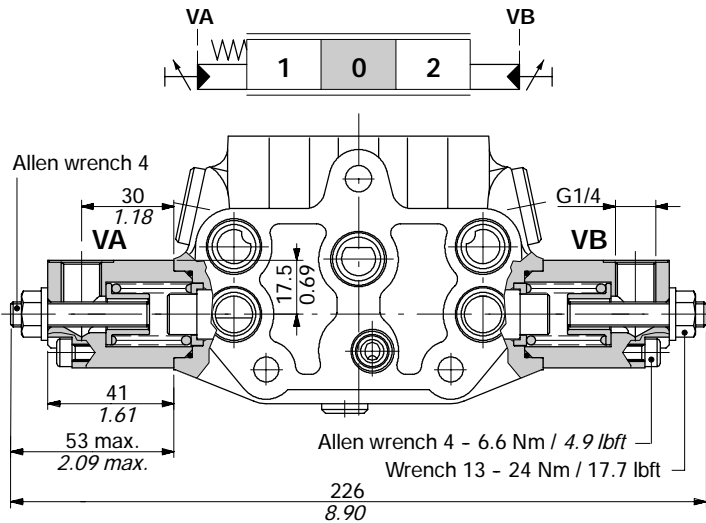

Available double acting spools

TYPE	CODES						DESCRIPTION
	10 l/min	20 l/min	30 l/min	40 l/min	50 l/min	60 l/min	
	D	V	T	Q	C	S	Nominal flow with 14 bar / 203 psi stand-by
6	3CU3310010	3CU3310020	3CU3310030	3CU3310040	3CU3310050	3CU3310060	3 pos., with A and B closed in neutral pos.
7	3CU3325010	3CU3325020	3CU3325030	3CU3325040	3CU3325050	3CU3325060	3 pos., with A and B to tank in neutral pos.

Connection example

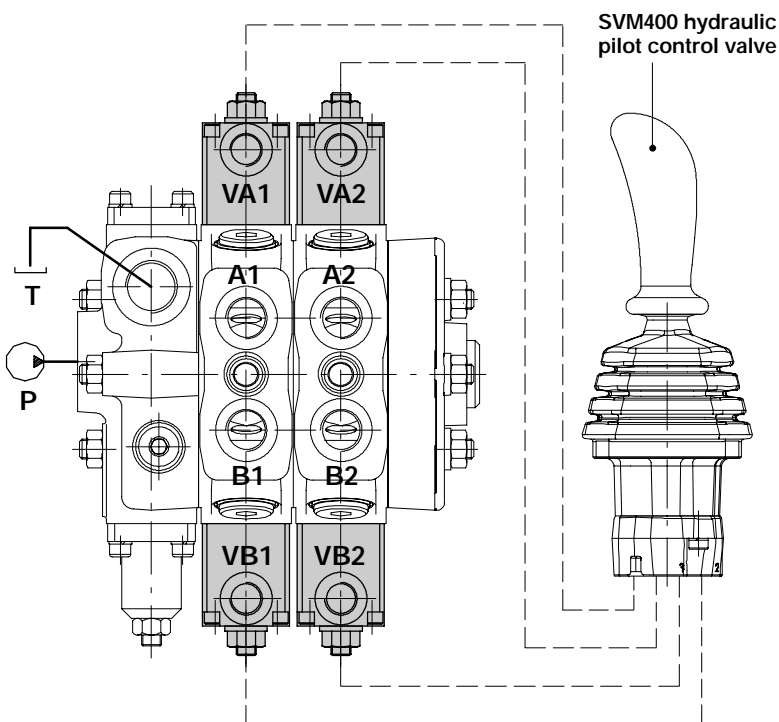

8IMF3 control kit: curve 075 with step

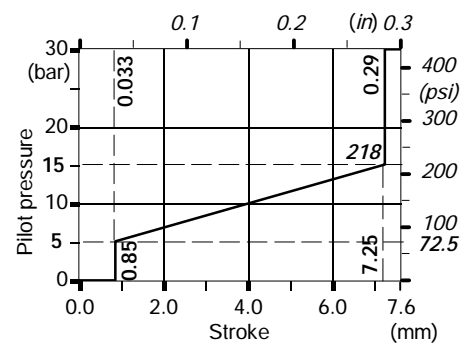

8IMF3 control kit: curve 178 without step

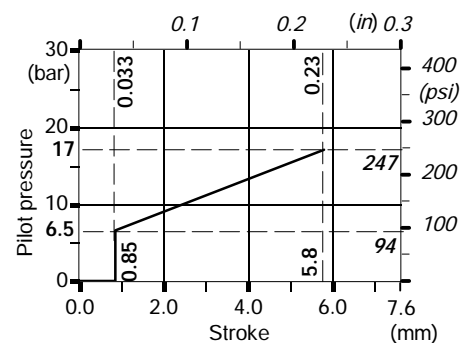

Dimensional data and hydraulic circuit

Type RF standard

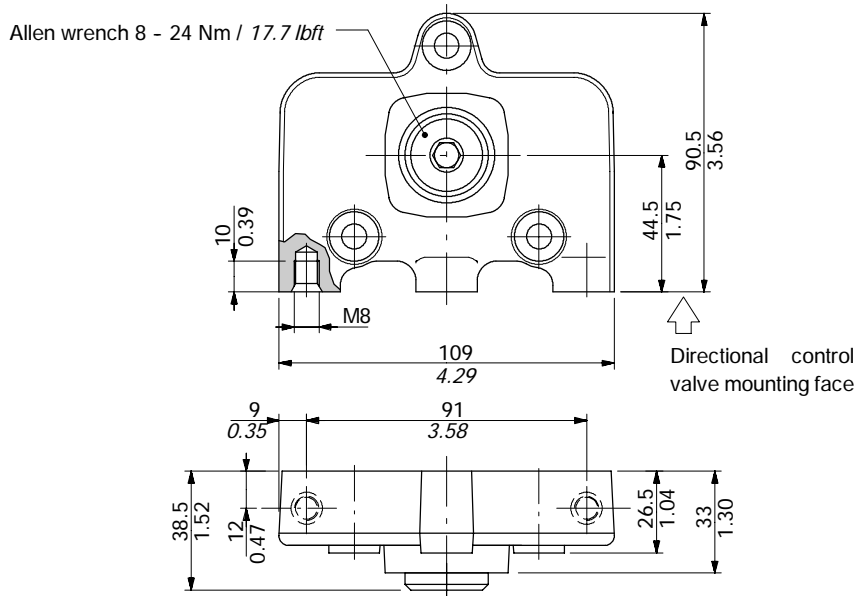

Type RH

With L.S. signal carry-over, for two DLS7 directional valve connection: dimensions are the same of RF return cover.

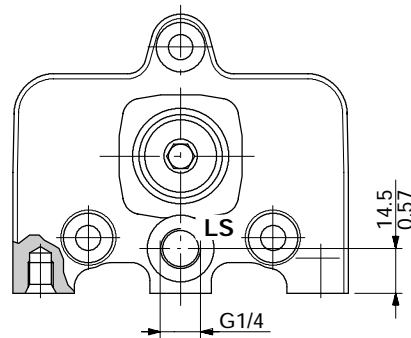

Hydraulic circuit example

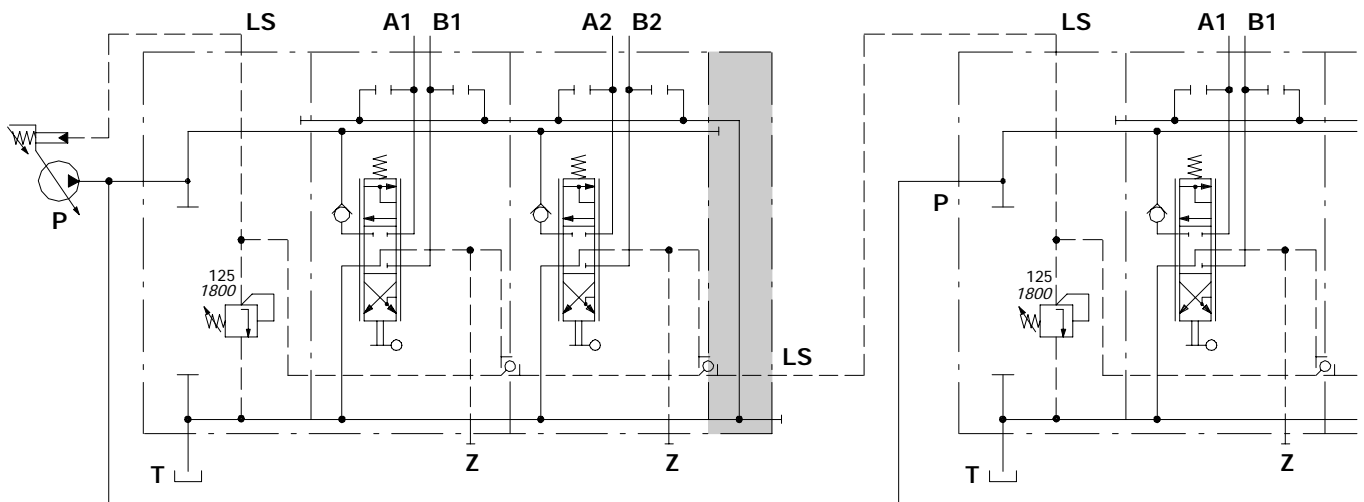

## Installation and maintenance

The SD6 and DLS7 valves are assembled and tested as per the technical specification of this catalogue.

Before the final installation on your equipment, follow the below recommendations:

- the valve can be assembled in any position; in order to prevent working section deformation and spool sticking mount the product on a flat surface;
- in order to prevent the possibility of water entering the lever box and spool control kit, do not use high pressure wash down directly on the valve;
- prior to painting, ensure plastic port plugs are tightly in place.

**SD6**

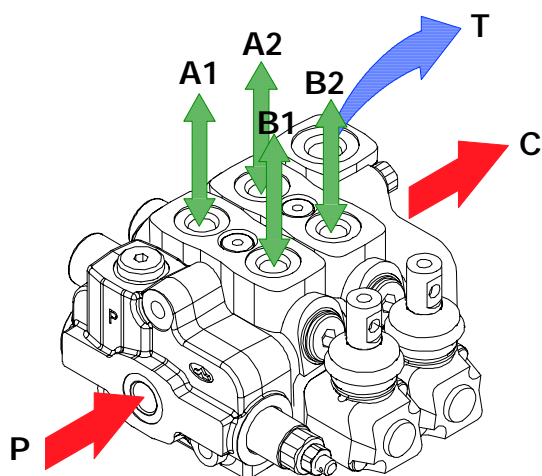

Configuration with carry-over

**DLS7**

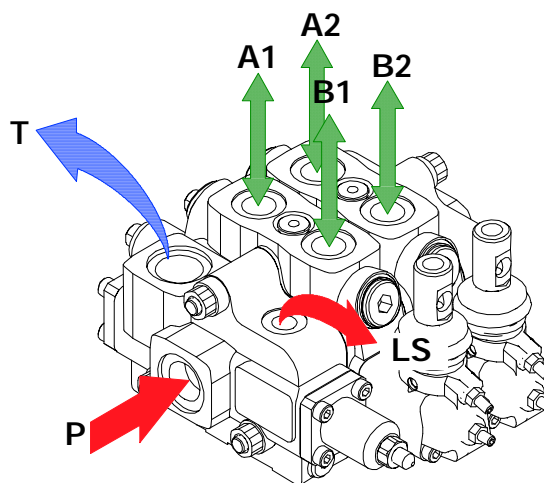

Configuration with AN inlet cover

## Fitting tightening torque - Nm / lbf

THREAD TYPE	SD6			DLS7		
	port P	ports A, B	ports C, T	ports P, T	ports A, B	LS signal
<b>BSP</b>	G 3/8	G 3/8	G 1/2	G 1/2	G 3/8	G 1/4
With O-Ring seal	35 / 25.8	35 / 25.8	50 / 36.9	50 / 36.9	35 / 25.8	20 / 15.7
With copper washer	40 / 29.5	40 / 29.5	60 / 44.3	60 / 44.3	40 / 29.5	25 / 18.4
With steel and rubber washer	30 / 22.1	30 / 22.1	60 / 44.3	60 / 44.3	30 / 22.1	16 / 11.8
<b>UN-UNF</b>	3/4-16 (SAE 8)	9/16-18 (SAE 6)	3/4-16 (SAE 8)	3/4-16 (SAE 8)	9/16-18 (SAE 6)	9/16-18 (SAE 6)
With O-Ring seal	50 / 36.9	30 / 22.1	50 / 36.9	50 / 36.9	30 / 22.1	30 / 22.1
<b>METRIC</b>	M18x1.5	M18x1.5	M22x1.5			
With O-Ring seal	35 / 25.8	35 / 25.8	50 / 36.9			
With copper washer	40 / 29.5	40 / 29.5	60 / 44			
With steel and rubber washer	40 / 29.5	40 / 29.5	60 / 44.3			

NOTE - These torque are recommended. Assembly tightening torque depends on many factors, including lubrication, coating and surface finish. The manufacturer shall be consulted.

It's shown a section of SD6/2/AC(YG3-175)/18L/18L/RC valve.

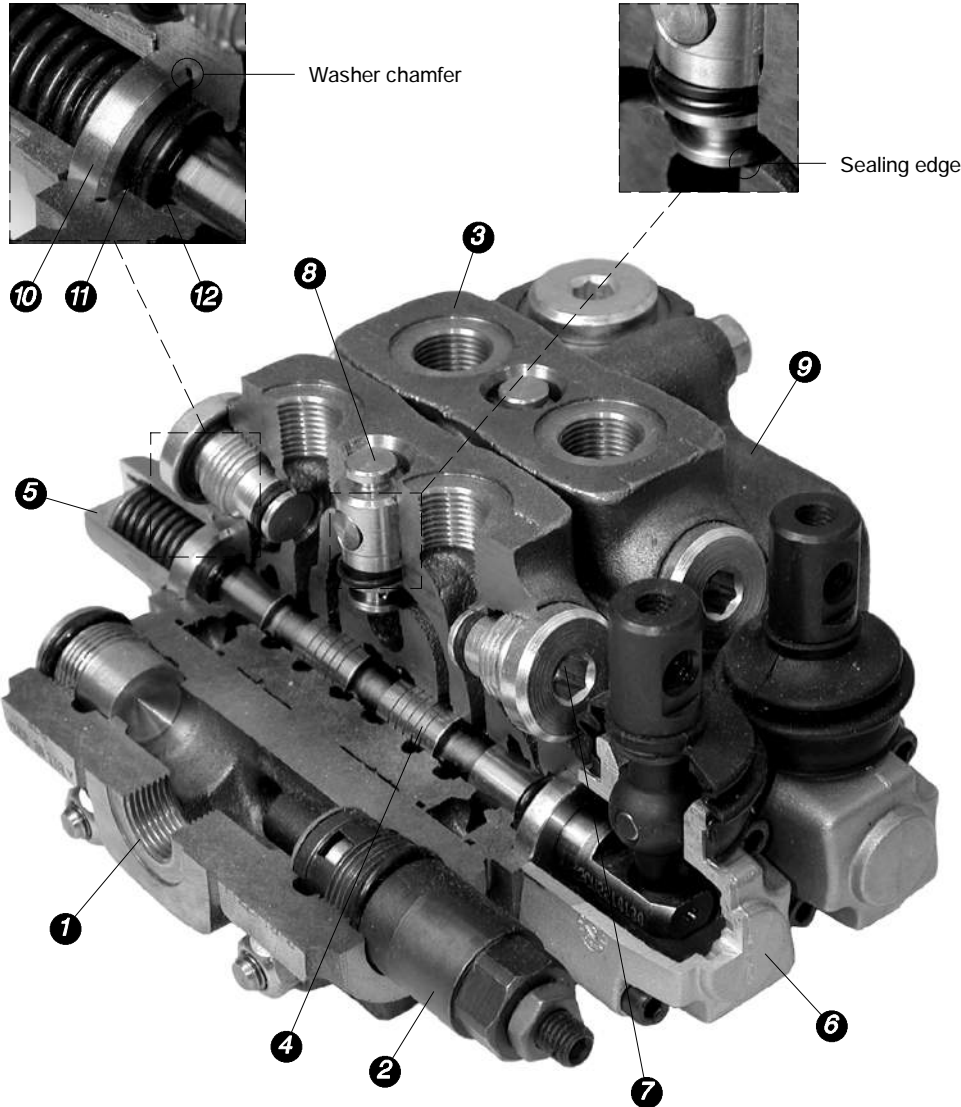

Callout	
1)	Inlet cover
2)	Overpressure relief valve
3)	Working section
4)	Spool: <i>normally spools are interchangeable, verify the smoothness during the assembly</i>
5)	"A" side spool positioner
6)	Lever pivot box
7)	Port relief valve prearrangement
8)	Load check valve
9)	Outlet cover
10)	Holding O-Ring washer
11)	16.26x2.18 Parback seal code: 4ANE816314
12)	15.88x2.62 O-ring seal code: 4GUA115926

NOTE - All moving parts inside cap, lever box and mechanical joystick are lubricated with synthetic base grease grade NLGI2

Malfunction	Cause	Remedy
External leakage pivot box lever or control kit side.	Worn spool seal due to mechanical actuation or high back pressure.	Locate the leakage and replace the seal. Check back pressure level.
Excessive internal leakage on A and B ports.	Increase clearance between spools and body due to high wear.	Replace the working section and check the oil contamination level.
Dropping load during transition while raising.	High leakage on the load check valve.	Remove the load check valve and clean the seat, verifying it's not dented.
Inability to build pressure on A and B ports.	Pressure relief valve blocked open. Low pump pressure and flow.	Remove and clean or replace the valve. Check the pump and circuit.

**Installation and maintenance**

It's shown a section of DLS7/2/AM(G3-120)/6V8MCLFG/6V8MCLFG/RF valve.

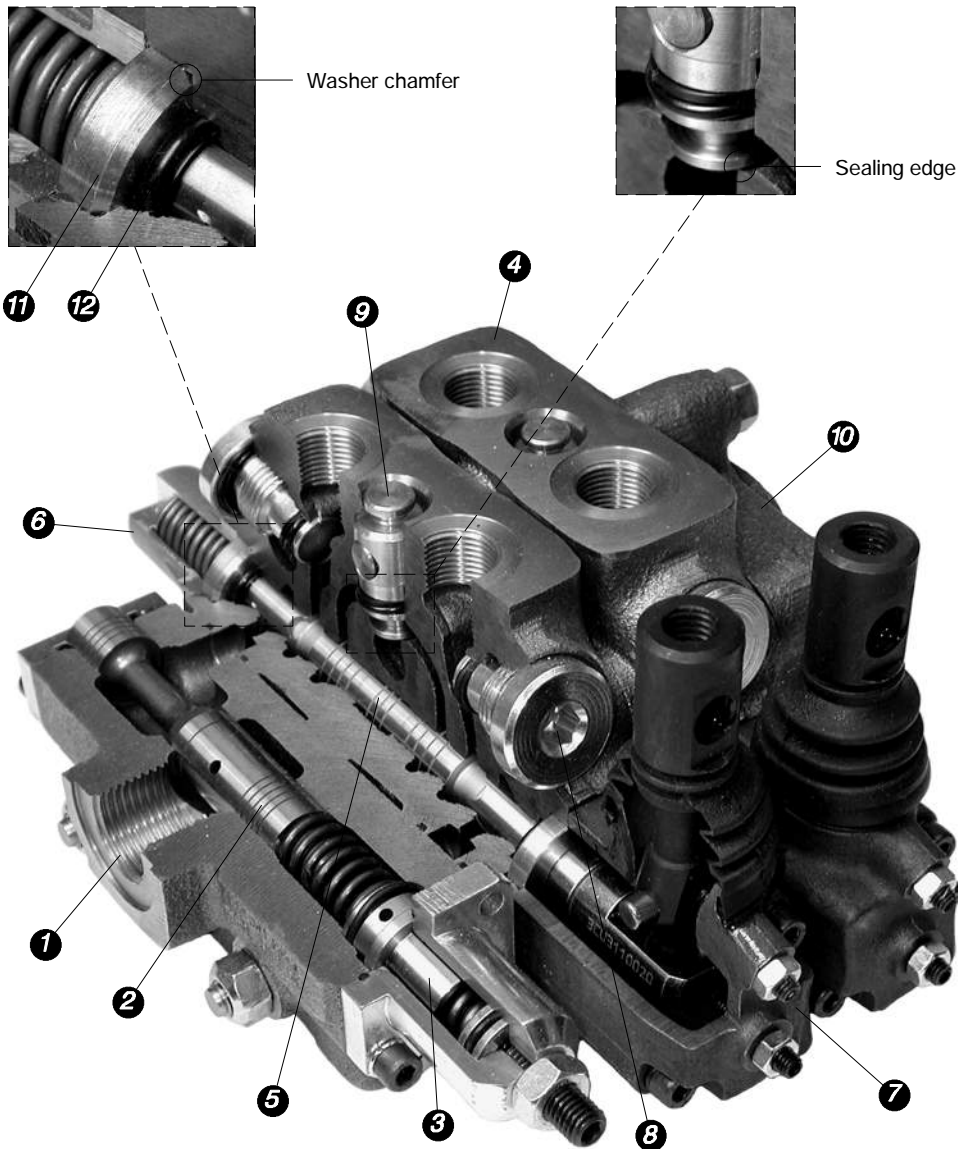

Callout	
1)	Inlet and outlet cover
2)	Compensator kit
3)	L.S. overpressure relief valve
4)	Working section
5)	Spool: <i>normally spools are inter_</i> <i>changeable, verify the smoothness</i> <i>during the assembly</i>
6)	"A" side spool positioner
7)	Lever pivot box
8)	Port relief valve prearrangement
9)	Load check valve
10)	Return cover
11)	Holding O-Ring washer
12)	15.88x2.62 O-ring seal code: 4GUA115926

NOTE - All moving parts inside cap, lever box and mechanical joystick are lubricated with synthetic base grease grade NLGI2

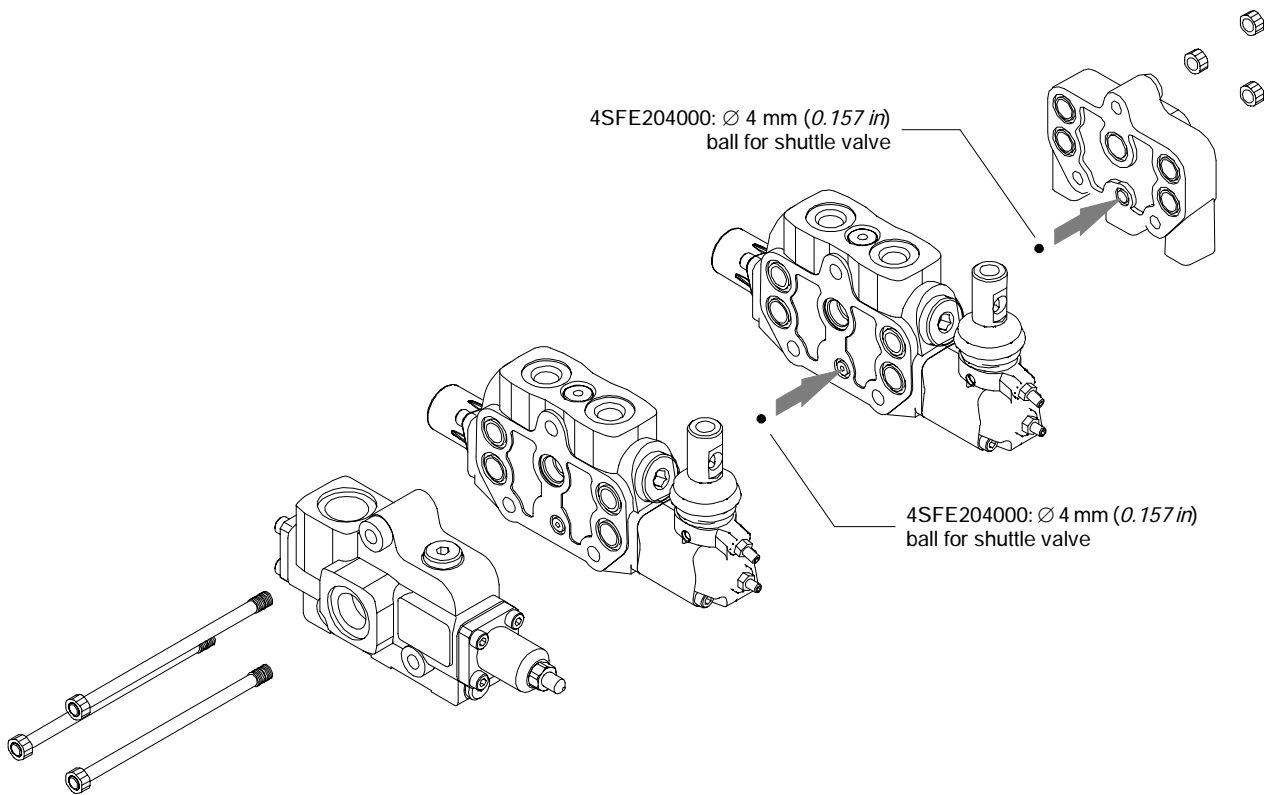

Malfunction	Cause	Remedy
External leakage pivot box lever or control kit side.	Worn spool seal due to mechanical actuation or high back pressure.	Locate the leakage and replace the seal. Check back pressure level.
Excessive internal leakage on A and B ports.	Increase clearance between spools and body due to high wear.	Replace the working section and check the oil contamination level
Dropping load during transition while raising.	High leakage on the load check valve.	Remove the load check valve and clean the seat, verifying it's not dented.
	L.S. overpressure valve blocked open.	Remove and clean or replace the valve.
	Low pump pressure and flow.	Check the pump and circuit.
Inability to build pressure on A and B ports out of stand-by value.	Flow compensator blocked open (only for AM configuration)	Remove and clean or replace the compensator.
	Shuttle valve on working section blocked	Disassembling directional valve and clean the seat, verifying it's not dented

Accessories

Connectors

**Type C01 code: 2X1001020**

2P+T, according to EN175301-803

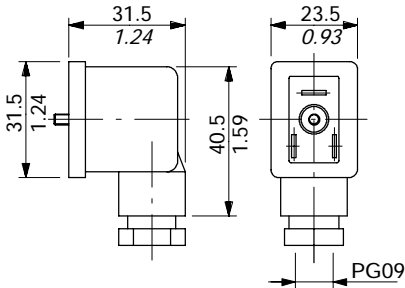

**Type C02 code: 2X1001010**

2P+T according to ISO4400 / EN175301-803

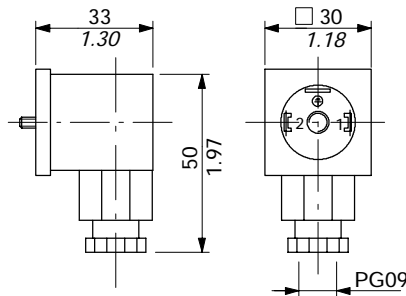

**Type C03 code: 2X1001030**

3P+T according to ISO4400 / EN175301-803

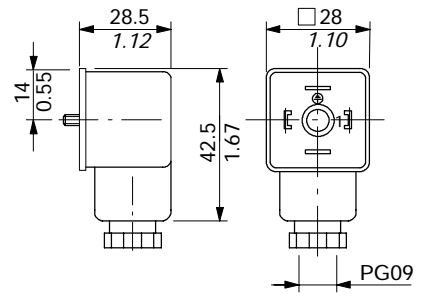

**Type C05 code: 2X1001080**

3P+T according to ISO4400 / EN175301-803.  
With bridge rectifier, to use with VAC supply.

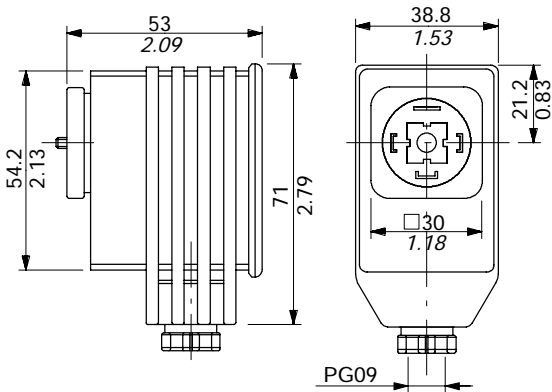

**Type C07 code: 5CON001**

2 Poles, type Packard male case with female contact

**Type C40 code: 5CON140047**

2 Poles, type Packard male case with male contact

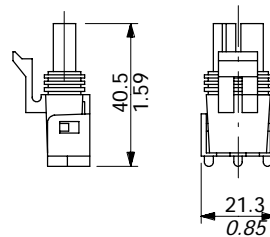

**Tipi C08 codice: 5CON003**

2P tipo AMP "Junior-Power-Timer" femmina con terminale femmina

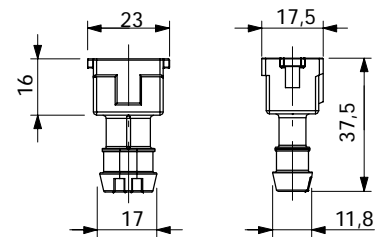

**Type C11 code: 5CON006**

4P according to VDE0660-0110

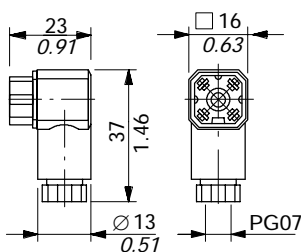

**Type C17 code: 5CON005**

2 Poles, type Packard female case with male contact

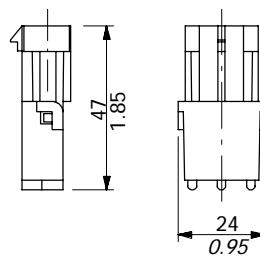

**Type C19 code: 5CON130030**

2 Poles, type Deutsch DT06-2S male case with female contact

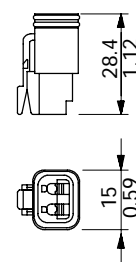

**Type C20 code: 5CON017**

2 pole, type "PACKARD Metri-Pack" male housing with female ends

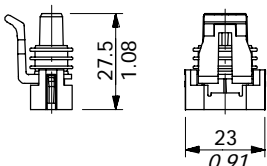

**Type C21 code: 5CON018**

2 poles, type "AMP Fastin-Faston" female housing with male ends

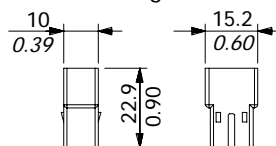

**Type C24 code: 5CON0031**

2 poles, type "AMP Superseal" male housing with female ends

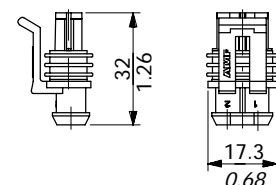

**Connectors**

Type	Poles	Nominal voltage	Nominal current	Permitted conductor section range	Permitted cable diameter range	Weather protection
C01	2P + T	250 VAC / 300 VDC	10 A	max.1.5 mm <sup>2</sup> / max.0.0023 in <sup>2</sup>	6 to 8 mm / 0.24 to 0.31 in	IP65
C02	2P + T	250 VAC / 300 VDC	10 A	max.1.5 mm <sup>2</sup> / max.0.0023 in <sup>2</sup>	6 to 8 mm / 0.24 to 0.31 in	IP65
C03	3P + T	250 VAC / 300 VDC	10 A	max.1.5 mm <sup>2</sup> / max.0.0023 in <sup>2</sup>	6 to 8 mm / 0.24 to 0.31 in	IP65
C05	3P + T	230 VAC	1.5 A	max.1.5 mm <sup>2</sup> / max.0.0023 in <sup>2</sup>	6 to 8 mm / 0.24 to 0.31 in	IP65
C06	3P + T	250 VAC / 300 VDC	6 A	max.0.75 mm <sup>2</sup> / max.0.00116 in <sup>2</sup>	3.5 to 6 mm / 0.14 to 0.24 in	IP65
C07	2P	/	20 A	1 to 2 mm <sup>2</sup> / 0.00155 to 0.0031 in <sup>2</sup>	2.8 to 3.5 mm / 0.11 to 0.14 in	IP67
C08	2P	250 VAC	12 A	0.5 to 1 mm <sup>2</sup> / 0.00077 to 0.00155 in <sup>2</sup>	1.3 to 1.6 mm / 0.05 to 0.063 in	IP65
C11	4P	50 VAC / 120 VDC	6 A	0.14 to 0.5 mm <sup>2</sup> / 0.00022 to 0.00077 in <sup>2</sup>	4 to 7.5 mm / 0.16 to 0.29 in	IP65
C17	2P	/	20 A	1 to 2 mm <sup>2</sup> / 0.00155 to 0.0031 in <sup>2</sup>	1.3 to 1.4 mm / 0.05 to 0.067 in	IP67
C19	2P	/	13 A	1 to 1.2 mm <sup>2</sup> / 0.00155 to 0.00186 in <sup>2</sup>	2.2 to 3.5 mm / 0.088 to 0.14 in	IP67
C20	2P	/	14 A	0.8 to 1 mm <sup>2</sup> / 0.00124 to 0.00155 in <sup>2</sup>	1.3 to 1.7 mm / 0.05 to 0.067 in	/
C21	2P	/	7A	0.3 to 0.8 mm <sup>2</sup> / 0.00046 to 0.0012 in <sup>2</sup>	2.2 to 3 mm / 0.087 to 0.118 in	/
C24	2P	/	14 A	0.3 to 5 mm <sup>2</sup> / 0.00046 to 0.00077 in <sup>2</sup>	1.4 to 1.7 mm / 0.055 to 0.067 in	IP67
C40	2P	/	20 A	1 to 2 mm <sup>2</sup> / 0.00155 to 0.0031 in <sup>2</sup>	2.8 to 3.5 mm / 0.11 to 0.14 in	IP67

**Fixing brackets**

They are available for SD6 and DLS7 directional valves and they are zinc plated steel, complete with mounting screws.

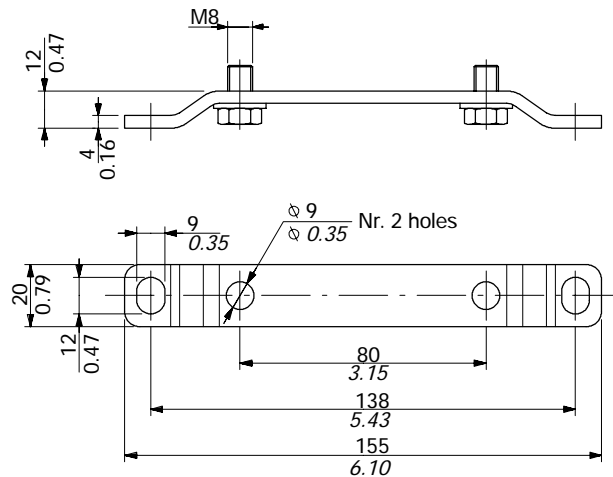
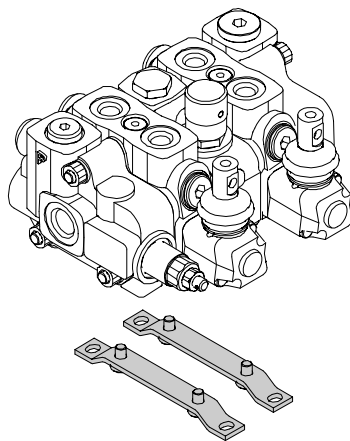

**Note**

SD6 and DLS7 valves can be supplied with one coat of black paint (CVN configuration).

Description example: SD6/2/AC(YG3-175)/18L/18L/RC-<CVN>

Description example: DLS7/2/AM(G3-120)/6V8MCLFG/6V8MCLFG/RF-<CVN>

NOTE - For different colour consult Sales Dept.



WALVOIL S.P.A.

42100 REGGIO EMILIA • ITALY • VIA ADIGE, 13/D  
TEL. +39.0522.932411 • FAX +39.0522.300984  
E-MAIL: INFO@WALVOIL.COM • HTTP: //WWW.WALVOIL.COM

SALES DEPARTMENT

TEL. +39.0522.932555 • FAX +39.0522.932455

DBU001E