

Variable displacement axial piston pump type V30E

Product documentation



Open circuit

Nominal pressure $p_{\text{nom max}}$:

350 bar

Peak pressure p_{max} :

420 bar

Displacement volume V_{max} :

270 cm³/rev

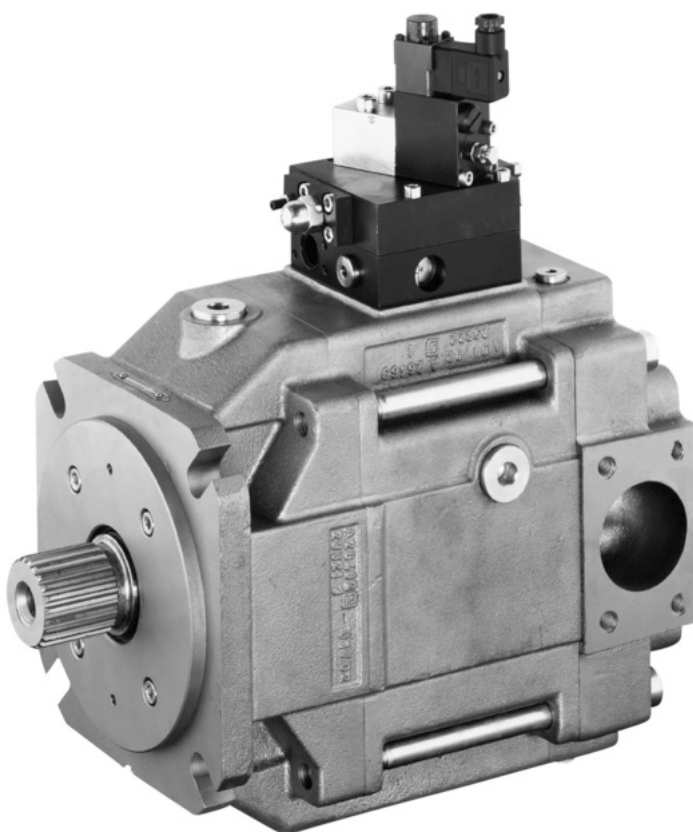

© by HAWE Hydraulik SE.

The reproduction and distribution of this document, as well as the use and communication of its contents to others without explicit authorization, is prohibited.

Offenders will be held liable for the payment of damages.

All rights reserved in the event of patent or utility model applications.

Brand names, product names and trademarks are not specifically indicated. In particular with regard to registered and protected names and trademarks, usage is subject to legal provisions.

HAWE Hydraulik respects these legal provisions in all cases.

HAWE Hydraulik cannot provide individual guarantees that the stated circuits or procedures (including in part) are not subject to the intellectual property rights of third parties.

Printing date / document generated on: 2026-04-30

Table of Contents

1	Overview: variable displacement axial piston pump type V30E.....	4
2	Available versions.....	5
2.1	Basic type and nominal size.....	5
2.2	Rotation direction.....	6
2.3	Shaft journal.....	6
2.4	Flange version (input side).....	6
2.5	Seals.....	7
2.6	Thru-shaft.....	7
2.7	Swivel angle indicator.....	7
2.8	Controller.....	7
2.8.1	Pressure controller P, Pb.....	9
2.8.2	Load-sensing controller LSP, LSPb.....	10
2.8.3	Power controller L, Lf, Lf1, Lfe.....	11
2.8.4	Controller BVPM, PM.....	12
2.8.5	Flow controller V, EM.CH.....	13
2.9	Flange version (output side).....	16
3	Parameters.....	18
3.1	General data.....	18
3.2	Weight.....	19
3.3	Pressure and delivery flow.....	19
3.4	Characteristic lines.....	20
3.4.1	Basic pump.....	20
3.4.2	Swivel angle pick-up.....	22
3.4.3	Controllers.....	23
4	Dimensions.....	26
4.1	Basic pump.....	26
4.1.1	Type V30E-095.....	26
4.1.2	Type V30E-160.....	30
4.1.3	Type V30E-270.....	34
4.2	Swivel angle indicator.....	39
4.3	Controllers.....	40
4.4	Pump combinations.....	45
4.4.1	Tandem pumps.....	45
4.4.2	Combination with gear pump.....	47
5	Installation, operation and maintenance information.....	48
5.1	Intended use.....	48
5.2	Assembly information.....	48
5.2.1	General information.....	48
5.2.2	Connections.....	49
5.2.3	Installation positions.....	50
5.2.4	Tank installation.....	51
5.3	Operating instructions.....	52
5.3.1	Limitations.....	53
5.4	Maintenance information.....	53
6	Other information.....	54
6.1	Planning information.....	54

1**Overview: variable displacement axial piston pump type V30E**

Variable displacement axial piston pumps adjust the geometric output volume from maximum to zero. As a result they vary the flow rate that is provided to the consumers.

The axial piston pump type V30E is designed for open circuits in mobile hydraulics and operates on the swash plate principle. It is available with the option of a thru-shaft for operating with additional hydraulic pumps in series.

The sturdy pump is particularly suitable for continuous operation in challenging applications. The range of pump controllers allows the axial piston pump to be used in a variety of applications.

Features and advantages

- Low-noise
- Broad selection of controllers
- Full torque available at the second pump in tandem pump applications

Intended applications

- Machines for forestry and agricultural purposes
- Cranes and lifting equipment
- Construction machines

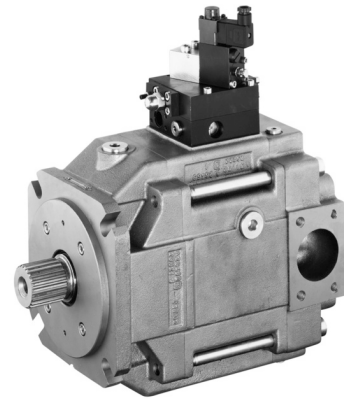

Variable displacement axial piston pump type V30E

2 Available versions

Circuit symbol

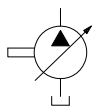

Ordering example

V30E-095	R	D	G	N	-2	-0	-02	/PL	-200	-C 211	-Z 05
											4.4.2 "Combination with gear pump"
											2.9 "Flange version (output side)"
											Pressure setting (nominal pressure) (bar)
											2.8 "Controller"
											Manufacturing series
											2.7 "Swivel angle indicator"
											2.6 "Thru-shaft"
											2.5 "Seals"
											2.4 "Flange version (input side)"
											2.3 "Shaft journal"
											2.2 "Rotation direction"
											2.1 "Basic type and nominal size"

2.1 Basic type and nominal size

Type	Displacement volume (cm ³ /rev)	Nominal pressure p _{nom} (bar)	Peak pressure p _{max} (bar)
V30E-095	98	350	420
V30E-160	160	350	420
V30E-270	270	350	420



NOTICE

When using HFC pressure fluid p_{max} = 300 bar, see Chapter 2.5, "Seals", coding C.

2.2 Rotation direction

Coding	Description
L	Anti-clockwise
R	Clockwise

When looking at the shaft journal.

2.3 Shaft journal

Coding	Description	Designation/standard	for	Max. drive torque (Nm)
D	Spline shaft	W45x2x21x9g DIN 5480	V30E-095	1200
		W50x2x24x9g DIN 5480	V30E-160	1700
		W60x2x28x9g DIN 5480	V30E-270	3400
K	Parallel key	Ø40 - 12x8x80 DIN 6885	V30E-095	650
		Ø50 - 14x9x80 DIN 6885	V30E-160	850
		Ø60 - 18x11x100 DIN 6885	V30E-270	1700
S	Spline shaft	SAE-D J 744 13T 8/16 DP 44-4 DIN ISO 3019-1	V30E-095, V30E-160	1200
		17T 8/16 DP	V30E-270	3100
U	Spline shaft	SAE-D J 744 13T 8/16 DP 44-4 DIN ISO 3019-1	V30E-270	1200

NOTICE

Coding K: For a pressure setting of over 300 bar, a power controller must be used.

2.4 Flange version (input side)

Coding	Description	Designation	for
G	Flange	160 B4 HW DIN ISO 3019-2	V30E-095
		180 B4 HW DIN ISO 3019-2	V30E-160, V30E-270
F	Flange	SAE-D 4-hole J 744 152-4 DIN ISO 3019-1	V30E-095, V30E-160
		SAE-E 4-hole J 744 165-4 DIN ISO 3019-1	V30E-270
W	Flange	SAE-D 4-hole J 744 152-4 DIN ISO 3019-1	V30E-270

2.5 Seals

Coding	Description
N	NBR
V	FKM
E	EPDM
C	NBR, suitable for HFC, for restrictions see Chapter 5, "Installation, operation and maintenance information"

2.6 Thru-shaft

Coding	Description
1	no thru-shaft
2	Thru-shaft for tandem pump

2.7 Swivel angle indicator

Coding	Description
0	without display
1	with display
2	With swivel angle sensor 0.5 - 4.5 V
3	With display and swivel angle sensor 4 - 20 mA
5	With display and swivel angle sensor 0.5 - 4.5 V

2.8 Controller

Load-sensing controller

Coding	Description
LSP	Load-sensing controller with integrated pressure limitation
LSPb	Load-sensing controller with integrated pressure limitation and external pump pressure signal

Pressure controller

Coding	Description
P	Pressure controller with remote-control port for external pilot valve
Pb	Pressure controller with remote-control port for external pilot valve and external pump pressure feedback
PMVPS4 -41/G 12 -42/G 24 -43	Pressure range: -41: (5) to 180 bar -42: (5) to 290 bar -43: (5) to 440 bar Additional, directly mounted electro proportional pressure-limiting valve
BVPM1 S /GM 12 R /GM 24	S: NO contact R: N/C contact Additional, directly mounted 2/2-way directional seated valve for one pump direction switching circuit

Power controller

Coding	Description
L, Lw	Power controller with fixed setting value
Lf	Hydraulically adjustable power controller with increasing characteristic curve
Lf1	Hydraulically adjustable power controller with decreasing characteristic curve
Lfe	Electrically adjustable power controller with increasing characteristic curve

Delivery flow controller

Coding	Description
V	Electro-proportional delivery flow controller with increasing characteristic curve
EM.CH	Electro-hydraulic flow controller

2.8.1 Pressure controller P, Pb

P- and Pb-controllers are pressure controllers with fixed pressure setting. As soon as the pump pressure exceeds the set value, the pressure controller reduces the swivel angle of the pump and adjusts the pressure level to a constant value. Depending on the controller type, the pressure is set either using an adjusting screw directly on the controller or using an external pilot valve on port X.

Coding **P**

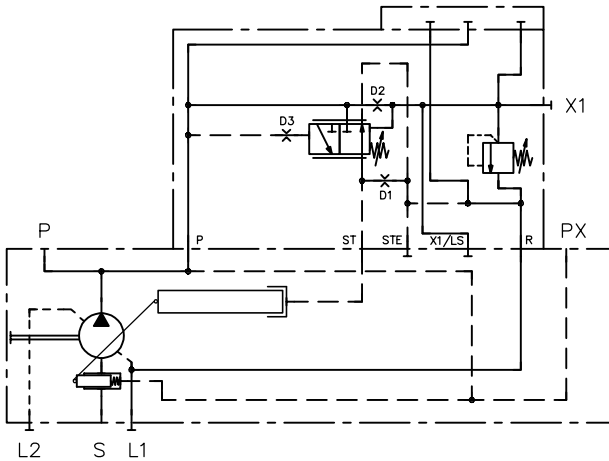

Coding **Pb**

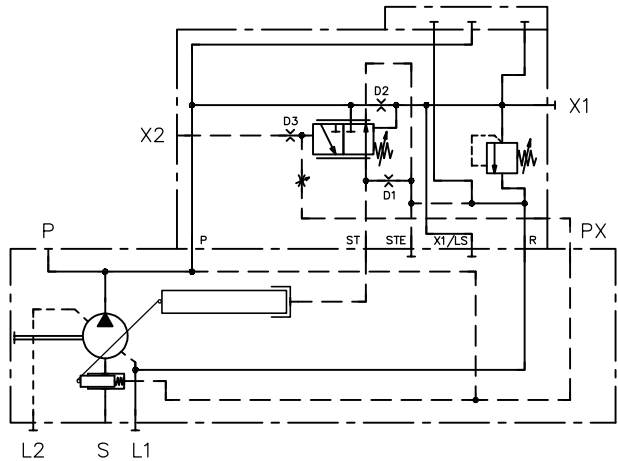

Coding **PL**

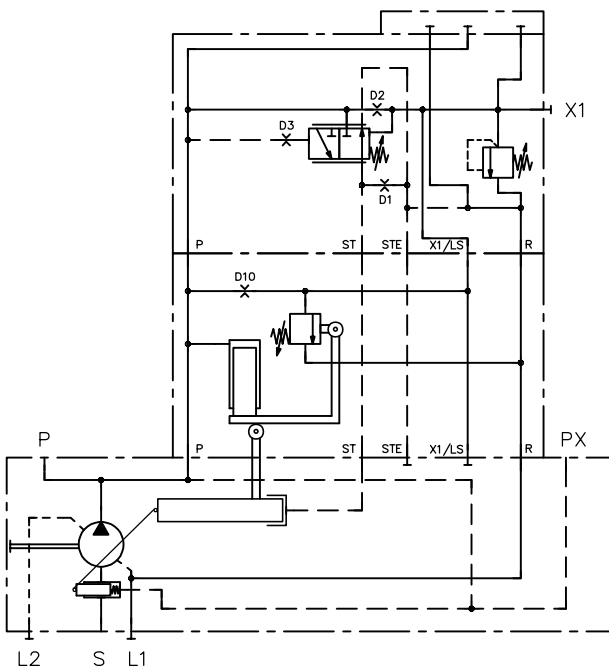

System pressure is tapped within the controller (internal).

The system pressure is tapped externally and signalled to port X2 to compensate any potential pressure losses in the system.

2.8.2 Load-sensing controller LSP, LSPb

The LSP and LSPb controllers are flow controllers that generate a variable, speed-independent flow rate. The controller adapts the displacement volume of the pump to the required flow rate of the consumer and regulates a constant difference between load pressure and pump pressure.

Coding LSP

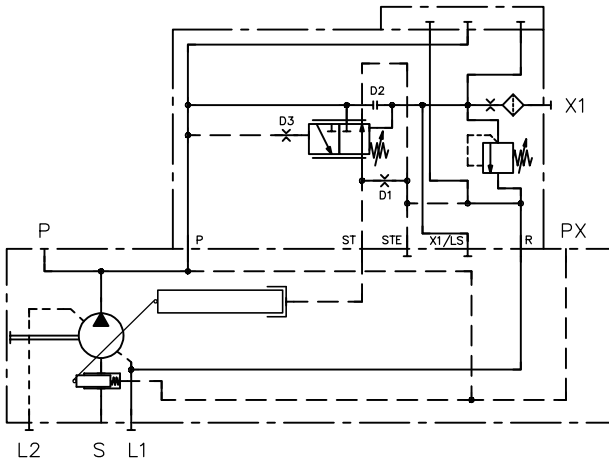

System pressure is tapped within the controller (internal).

Coding LSPb

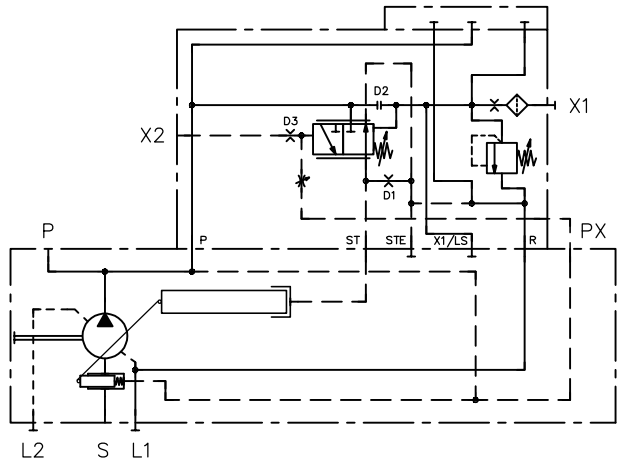

The system pressure is tapped externally and signalled to port X2 to compensate any potential pressure losses in the system.

2.8.3 Power controller L, Lf, Lf1, Lfe

L, Lf, Lf1, Lfe controllers are power controllers whose characteristic line is a perfect hyperbola. When the product of displacement volume times pressure exceeds the set value, the controller reduces the pump's swivel angle. This protects the drive shaft, motor or gearbox from overloading ($p_B \times V_g = \text{constant}$).

The power controllers are only available in combination with a pressure- or load-sensing controller.

Coding **LSPLf**

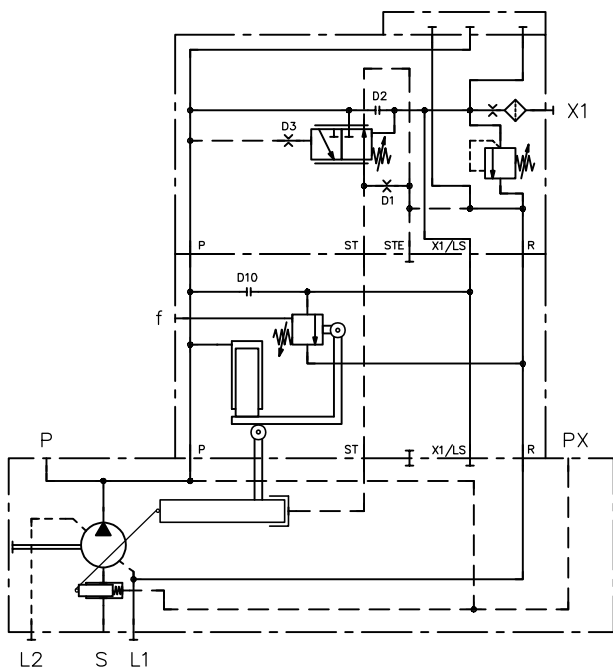

Coding **LSPLf1**

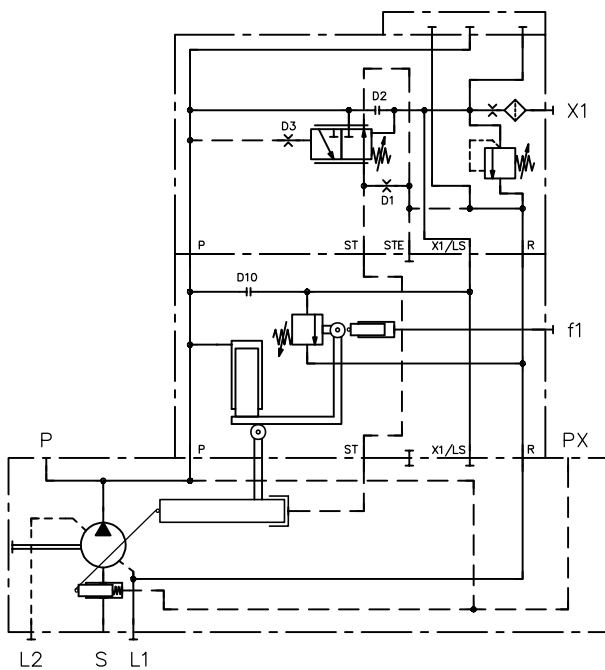

Coding **LSPL**

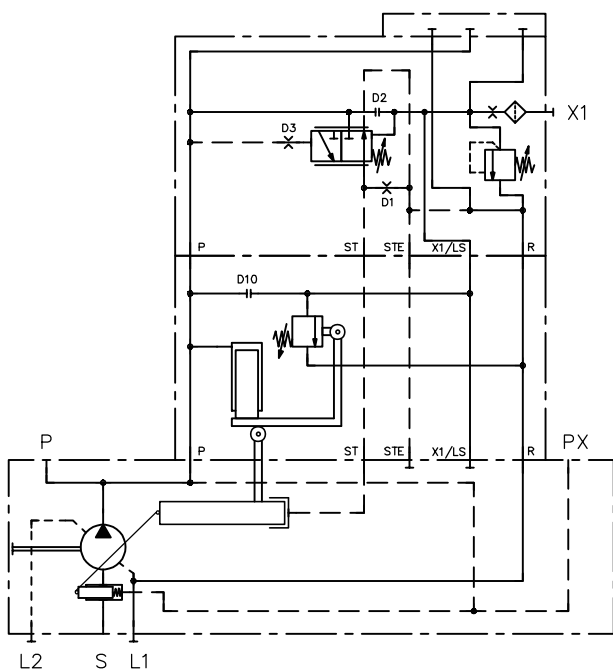

Coding **LSPLfe**

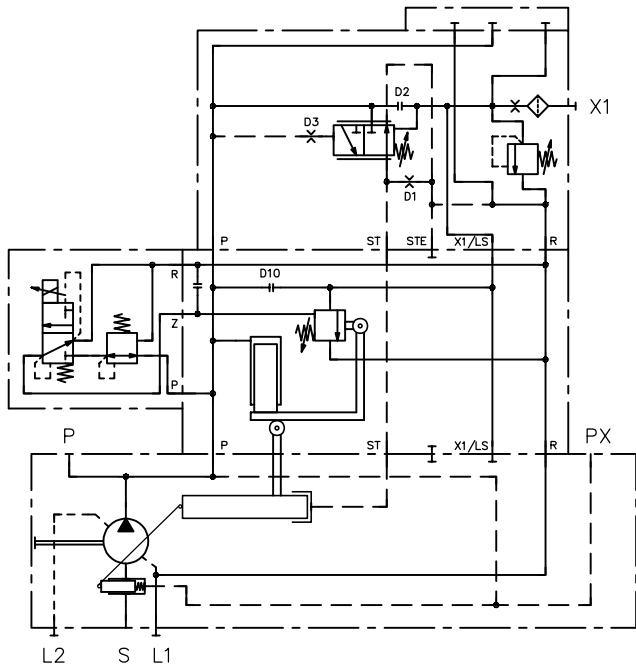

2.8.4 Controller BVPM, PM

Coding **BVPM1R**

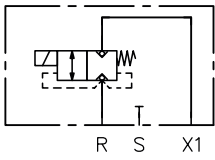

Coding **BVPM1S**

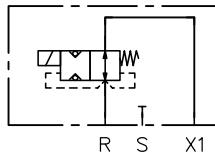

Coding **PMVPS4**

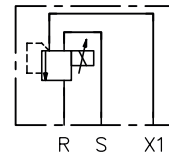

2.8.5 Flow controller V, EM.CH

V controller

The V controller is an electro-proportional flow controller that generates a variable flow rate depending on the speed. The controller adjusts the pump's displacement volume based on an electrical input signal. The resulting flow rate depends on the displacement volume and speed.

The required pilot pressure for adjusting the swivel angle is tapped internally. An external auxiliary pump or a pre-load valve is required to ensure reliable switching.

Coding **V**

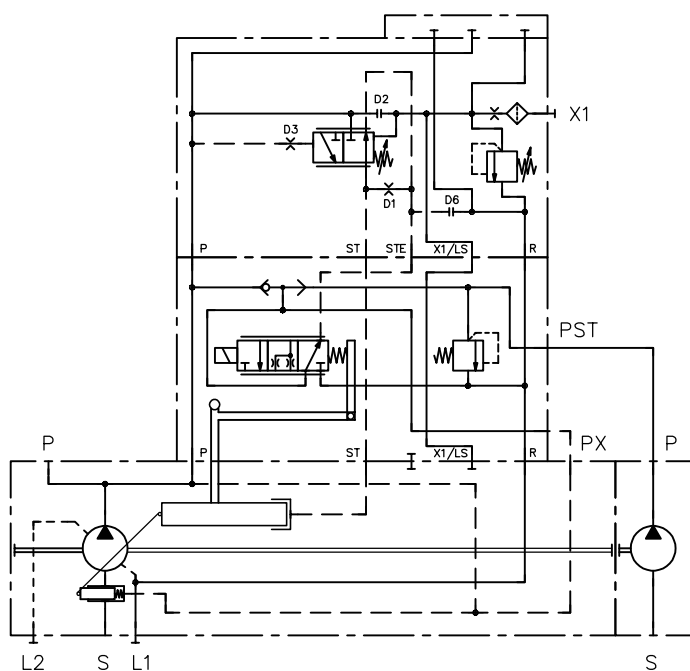

EM.CH controller

The electro-hydraulic delivery flow controller EM.CH adjusts the displacement volume of the pump between "zero" and "maximum" in proportion to an electrical input signal (target 0–10 V or 0–20 mA).

The power for the adjustment is taken from the high-pressure line. System pressures under 50 bar will require an additional auxiliary pump (thru-shaft).

Associated auxiliary pump: V30E-09S: Z 02-6, V30E-160: Z 02-8, V30E-270: Z 02-11

The control system consists of the pump adjustment system, an NG 6 prop. directional valve and a swivel angle pick-up (coding 2) for actual value determination.

Control electronics (coding CH, type DAC-4) compare the setpoint and actual values and supply the solenoid valves with the appropriate current. The control electronics used offer a wide range of options for individual adaptation, such as ramps and setpoint recall.

Coding **EMOCH**

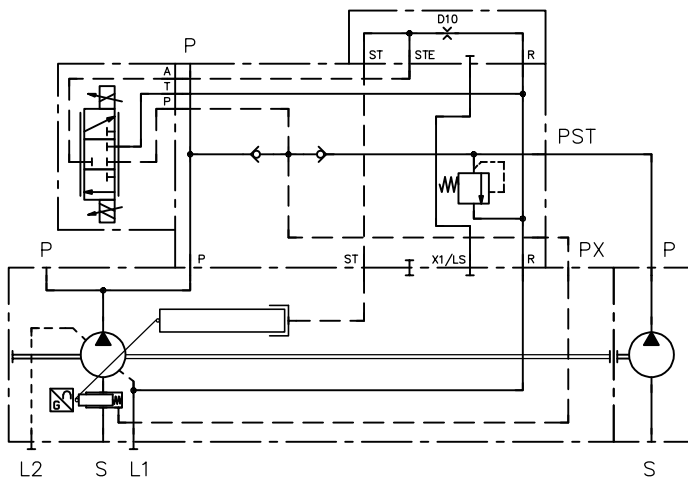

Coding **EMPCH**

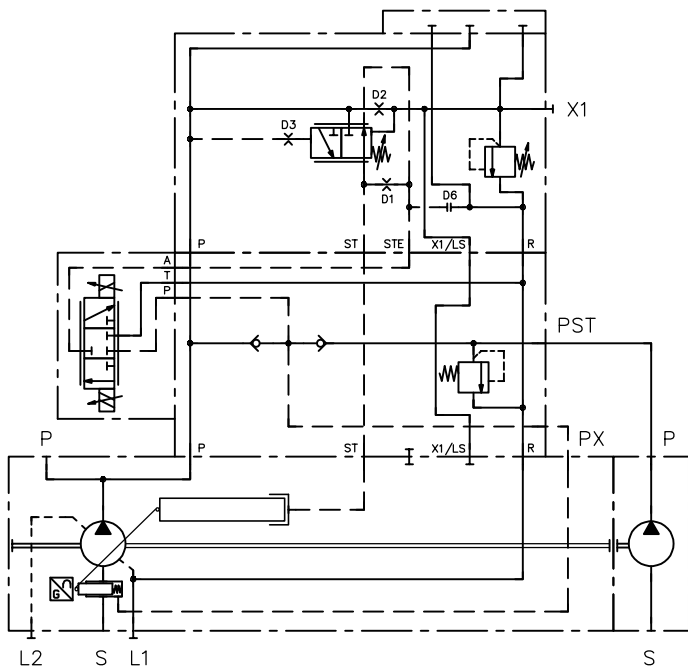

Coding **EMPLCH**

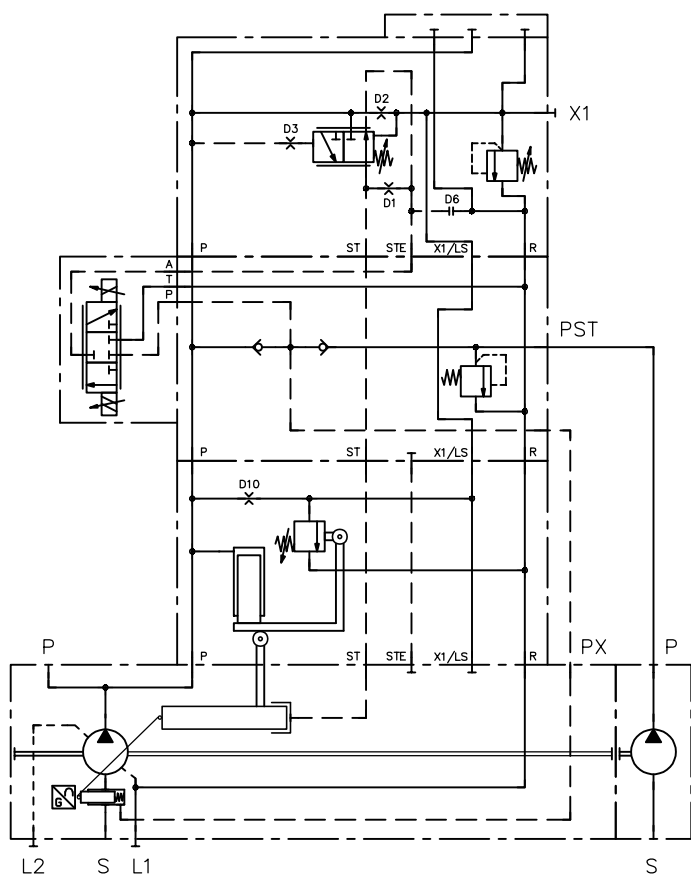

! NOTICE

The adjustment times are approx. 200 ms.

The EM.CH controller can be combined with pressure, LS and/or power controllers to limit pressure and/or power.

! NOTICE

Additional, separately laid out overpressure protection (pressure-limiting valve) must be included in the hydraulics circuit in order to prevent pressure peaks.

Ordering example

Version without pressure limitation and power controller:

V30E-160 R S F N -1 -1 -XX /EMOCH

Version with pressure and power controller:

V30E-270 L D G N -2 -1 -XX /EMLPCH -350 -2250 -C232 -Z11

2.9 Flange version (output side)

Ordering example:

V30E-160 RDGN-2-0-04/LSP-350- C 222

Coding V30E			Flange	Shaft	e.g. mounting of HAWE pump with coding
095	160	270			
C 211	C 221	C 231	SAE-A 2-hole J 744 82-2 DIN ISO 3019-1	SAE-A J 744 (16-4 DIN ISO 3019-1) 9T 16/32 DP	
C 212	C 222	C 232	SAE-A 2-hole J 744 82-2 DIN ISO 3019-1	SAE-A J 744 (16-4 DIN ISO 3019-1) 9T 16/32 DP 1)	
C 213	C 223	--	SAE-A 2-hole J 744 82-2 DIN ISO 3019-1	19-4 DIN ISO 3019-1 11T 16/32 DP	
C 214	C 224	C 234	SAE-B 2-hole J 744 101-2 DIN ISO 3019-1	SAE-B J 744 (22-4 DIN ISO 3019-1) 13T 16/32 DP	V60N-060 .. HX
C 215	C 225	C 235	SAE-B 4-hole J 744 101-4 DIN ISO 3019-1	SAE-B J 744 (22-4 DIN ISO 3019-1) 13T 16/32 DP	V60N-060 .. HZ
C 216	C 226	C 236	SAE-B 2/4-hole 101-2/4 DIN ISO 3019-1	SAE-BB J 744 (25-4 DIN ISO 3019-1) 15T 16/32 DP	V40M
--	C 227	C 237	SAE-C 2-hole J 744 127-2 DIN ISO 3019-1	SAE-C J 744 (32-4 DIN ISO 3019-1) 14T 12/24 DP	
C 218	C 228	C 238	SAE-C 4-hole J 744 127-4 DIN ISO 3019-1	SAE-C J 744 (32-4 DIN ISO 3019-1) 14T 12/24 DP	V60N- .. SF
--	C 229	--	SAE-C 4-hole J 744 127-4 DIN ISO 3019-1	23T 16/32 DP	
C 220	C 230	C 240	SAE-D 4-hole J 744 152-4 DIN ISO 3019-1	SAE-D&E J 744 (44-4 DIN ISO 3019-1) 13T 8/16 DP	V30E-095 ..SF.. /V30E-160 ..SF..
--	--	C 241	SAE-E 4-hole J 744 165-4 DIN ISO 3019-1	17T 8/16 DP	V30E-270 ..SF..
C 247	C 248	C 249	Prepared for thru-shaft (cover)		
C 250	C 255	C 260	160 B4 HW DIN ISO 3019-2	W45x2x21x9g DIN 5480	V30E-095 ..DG..
--	C 256	C 261	SAE-D 4-hole J 744 152-4 DIN ISO 3019-1	W45x2x21x9g DIN 5480	V30E-095 ..DF..
--	C 257	C 262	180 B4 HW DIN ISO 3019-2	W50x2x24x9g DIN 5480	V30E-160 ..DG..
--	--	C 263	SAE-D 4-hole J 744 152-4 DIN ISO 3019-1	W50x2x24x9g DIN 5480	V30E-160 ..DF..
--	--	C 264	180 B4 HW DIN ISO 3019-2	W60x2x28x9g DIN 5480	V30E-270 ..DG..
--	--	C 266	SAE-E 4-hole J 744 165-4 DIN ISO 3019-2	W60x2x28x9g DIN 5480	V30E-270 ..DF..
C 252	C 259	C 268	180 B4 HW DIN ISO 3019-2	Ø25 wedge width 8	R size 6014 (D 6010) RZ size 6914 (D 6910)
--	C 271	--	DIN ISO 7653 (for HGV)	DIN ISO 14 (for HGV) B8x32x35	V60N-090 ..DY..
C 276	C 277	--	SAE-CS 4-hole J744 127-4 DIN ISO 3019-1	SAE-CS J744 (/35-4 DIN ISO 3019-1) 21T 16/32 DP	

1) ANSI B 92.1, FLAT ROOT SIDE FIT spline width deviating from the standard, s = 2.357-0.03



NOTICE

Pay attention to the maximum permissible drive torque, as the flange or shaft may be damaged otherwise.

! NOTICE

- An additional support is to be provided for pump combinations.
- Additional versions on request.

3 Parameters

3.1 General data

Designation	Variable displacement axial piston pump		
Pump version	Axial piston pump according to the swash plate principle		
Mounting	Flange mounting or foot bracket		
Surface	Primed		
Drive/output torque	Max. permissible drive/output torque (Nm)		
	Nominal size		
	095	160	270/280
Spline shaft D	1200/600	1700/850	3400/1700
Parallel key K	650/600	850/850	1700/1700
Spline shaft S	1200/600	1200/850	3100/1700
Spline shaft U	--	--	1200/1200
Installation position	As desired Installation information see Chapter 5, "Installation, operation and maintenance information"		
Rotation direction	<ul style="list-style-type: none"> ▪ right ▪ left 		
Ports/connections	<ul style="list-style-type: none"> ▪ Suction port ▪ Pressure connection ▪ Drain port ▪ Pressure gauge connection 		
Hydraulic fluid	Hydraulic fluid, according to DIN 51524 Parts 1 to 3; ISO VG 10 to 68 according to DIN ISO 3448 Viscosity range: 10 - 1000 mm ² /s Optimal operating range: approx. 16 - 35 mm ² /s		
Cleanliness level	ISO 4406 <u>19/16/13</u>		
Temperatures	Environment: approx. -40 to +60 °C, hydraulic fluid: -25 to +80 °C, pay attention to the viscosity range. Start temperature: down to -40 °C is permissible (take account of the start viscosities!), as long as the steady-state temperature is at least 20 K higher during subsequent operation. Biologically degradable hydraulic fluids: note manufacturer specifications. With consideration for the seal compatibility, not above +70°C.		

Designation		Nominal size		
		095	160	270
Max. swash plate angle		15°	15°	15°
Absolute inlet pressure required in open circuit	bar	0.85	0.85	0.85
Minimum operating pressure	bar	15	15	15
Max. permissible housing pressure (static/dynamic)	bar	1/2	1/2	1/2
Max. permissible inlet pressure (static/dynamic)	bar	20/30	20/30	20/30
Max. rotation speed during suction operation and max. swash plate angle at 1 bar abs. inlet pressure	min ⁻¹	2500	2100	1800
Max. rotation speed with zero stroke and 1 bar abs. inlet pressure	min ⁻¹	2900	2500	2000
Min. speed in continuous operation	min ⁻¹	500	500	500
Required drive torque at 100 bar	Nm	153	261	414
Drive power at 250 bar and 1450 min ⁻¹	kW	66	107	177
Inertia torque	kg m ²	0.0216	0.03	0.0825
Noise level at 250 bar, 1450 min ⁻¹ and max. swash plate angle (measured in acoustic measurement chamber according to DIN ISO 4412-1 with measuring distance 1 m)	dB(A)	73	74	78

! NOTICE
The minimum operating pressure in the pump line depends on the rotation speed and the swivel angle; the pressure must not fall below 15 bar under any circumstances.

! NOTICE
The housing pressure is only allowed to be 1 bar higher than the suction pressure.

3.2 Weight

Type	Without controller	With controller			
		LSP, LSPb, P, Pb	PMVPS 4	L, Lf, Lf1, Lfe	EM...
V30E-095	54 kg	+ 2.5 kg	+ 1.1 kg	+ 2.5 kg	+ 6.1 kg
V30E-160	74 kg	+ 2.5 kg	+ 1.1 kg	+ 2.5 kg	+ 6.1 kg
V30E-270	126 kg	+ 2.5 kg	+ 1.1 kg	+ 2.5 kg	+ 6.1 kg

3.3 Pressure and delivery flow

Operating pressure see Chapter 2.1, "Basic type and nominal size"

Displacement volume see Chapter 2.1, "Basic type and nominal size"

3.4 Characteristic lines

3.4.1 Basic pump

Delivery flow and power

The diagram shows

- Delivery flow/pressure (without controller)
- Drive power at max. swash plate angle and drive power at zero stroke and 1500 min⁻¹
- Drive power/pressure at zero stroke and 1500 min⁻¹

V30E-095

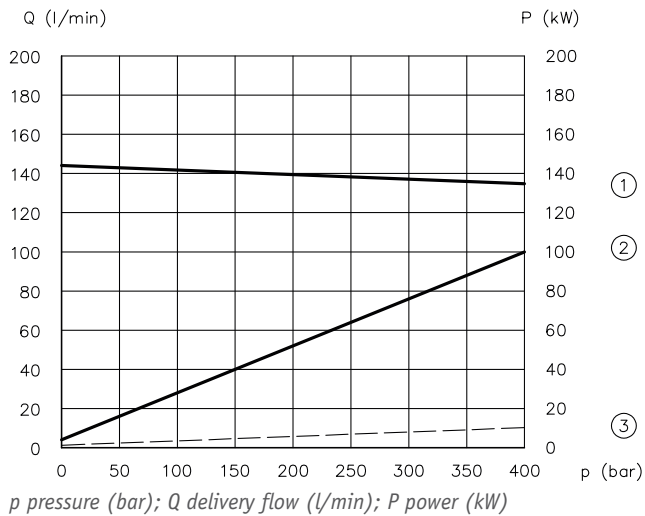

- 1 Delivery flow/pressure
- 2 Drive power/pressure
- 3 Drive power/pressure (zero stroke)

V30E-160

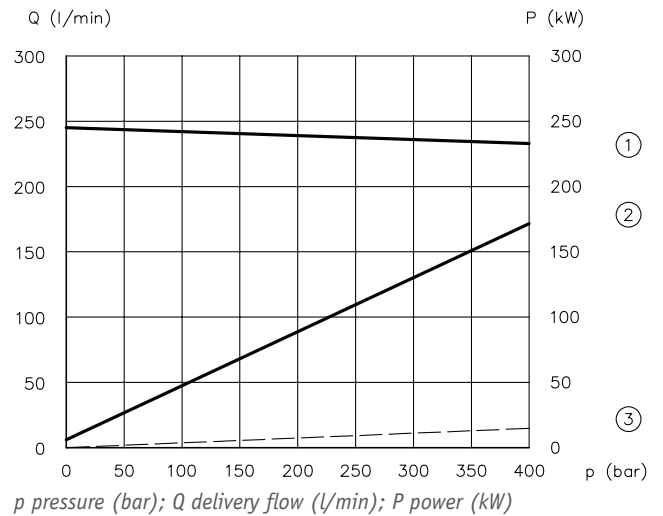

- 1 Delivery flow/pressure
- 2 Drive power/pressure
- 3 Drive power/pressure (zero stroke)

V30E-270

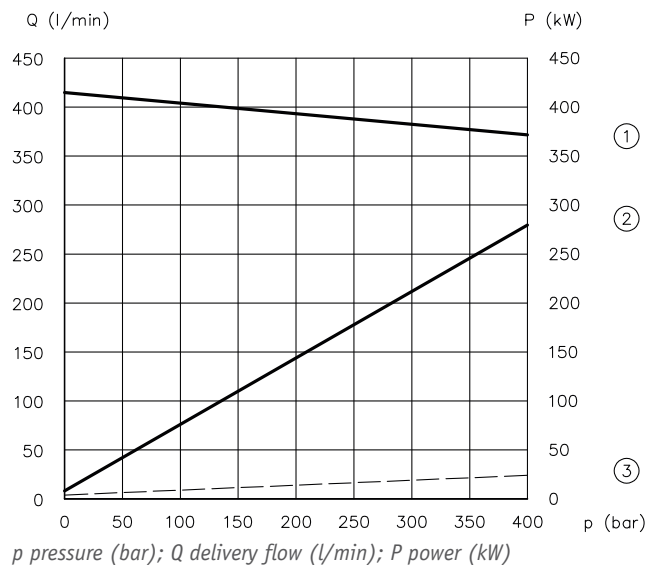

- 1 Delivery flow/pressure
- 2 Drive power/pressure
- 3 Drive power/pressure (zero stroke)

Inlet pressure and self-suction speed

The diagram shows the inlet pressure/rotation speed at max. swash plate angle and an oil viscosity of 75 mm²/s

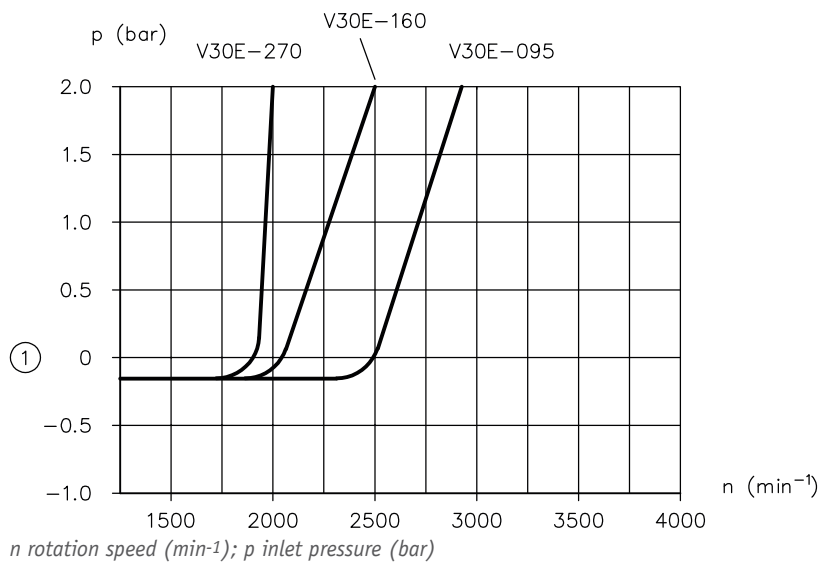

- 1 0 bar relative = 1 bar absolute

Acting times

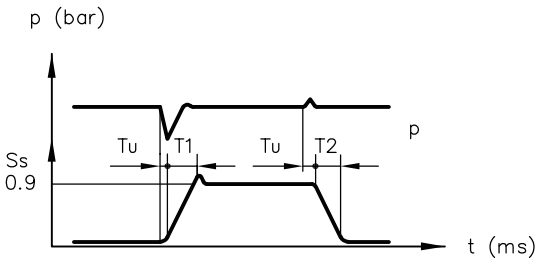

Ss Positioning travel of actuator

Tu Delay < 3 ms

T1 On-stroke time

T2 Destroke time

p Pressure

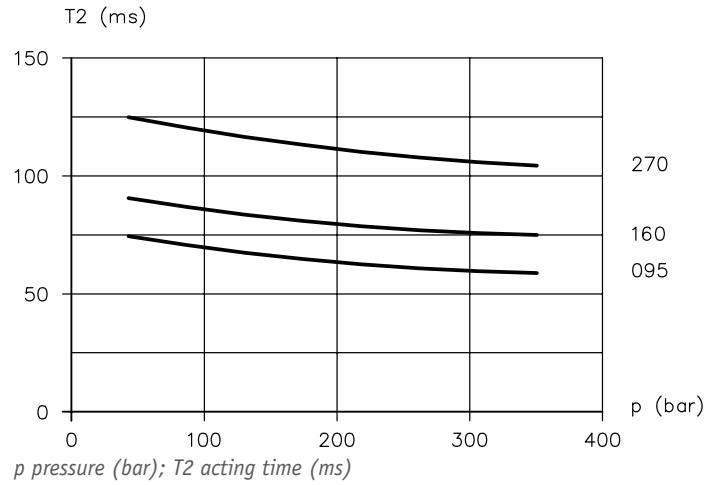
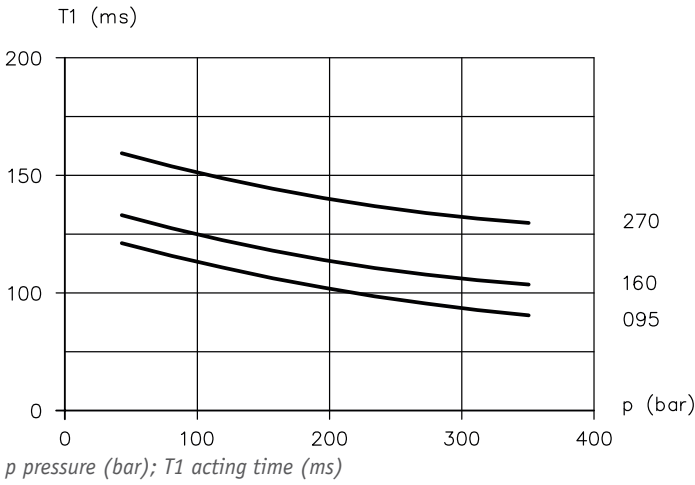

3.4.2 Swivel angle pick-up

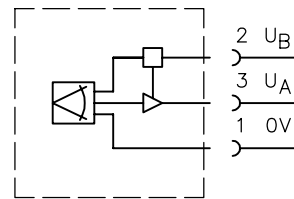
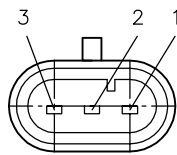
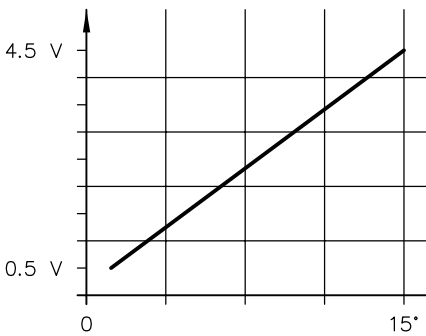

Operating voltage	UB 10 ... 30 V DC
Output signal	UA 0.5 ... 4.5 V
Tested for automotive field	DIN 40839
Test pulse	1, 2, 3 a/b
Electrical connection	3-PIN AMP Superseal 1.5 plug

3.4.3 Controllers

Load-sensing controller LSP

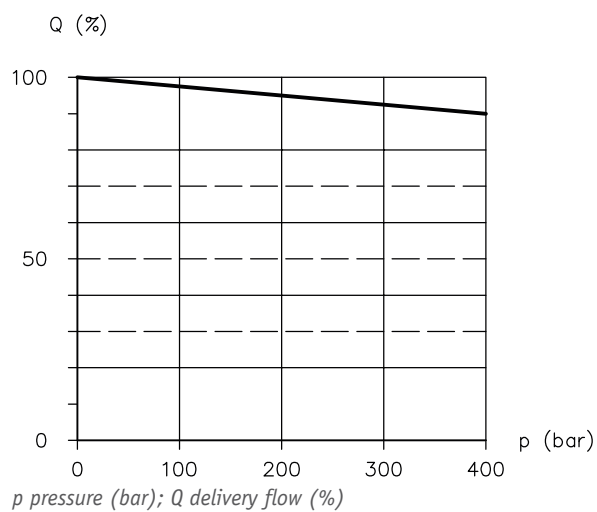

Drive speed constant
LS line approx. 10 % of the volume of the P line

Control accuracy in relation to max. delivery flow

- a) Speed n constant, pressure variable between 30 and 350 bar (< 3%)
- b) Pressure p constant, speed variable (< 1%)

Pressure controller P, PMVPS, BVPM

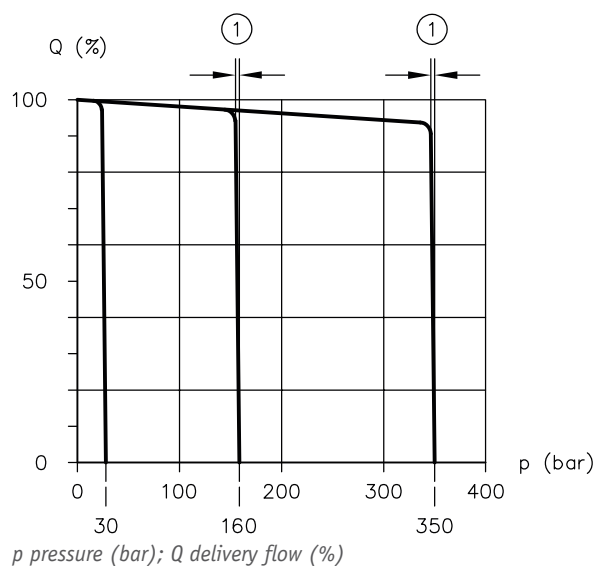

1 Approx. 4 bar

PMVPS 4

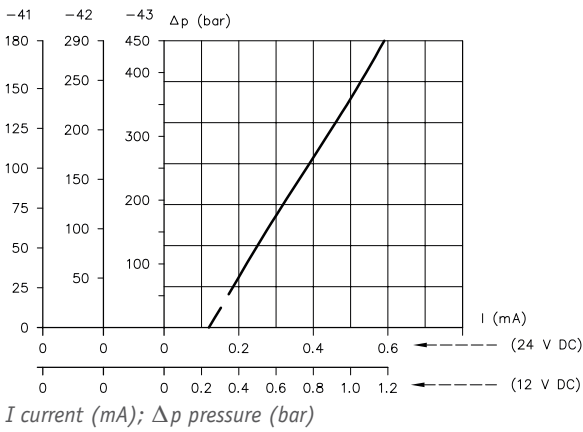

Nominal voltage U_N	12 V DC	24 V DC
Nominal current I_N	1.26 A	0.63 A
Nominal power P_N	9.5 W	9.5 W
Protection class	IP 65 (IEC 60529) for plug assembled as prescribed	
Required dither frequency	60 - 150 Hz	
Dither amplitude	30 to 60% of I_N	
Further information	D 7485/1	
Electrical connection	Industry standard (11 mm)	

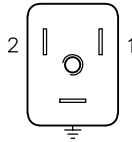

BVPM 1

Nominal voltage U_N	12 V DC	24 V DC
Nominal current I_N	2.2 A	1.1 A
Nominal power P_N	29.4 W	27.6 W
Protection class	IP 65 (IEC 60529) for plug assembled as prescribed	
Further information	D 7765	
Electrical connection	EN 175 301-803 A	

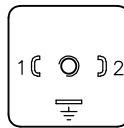

Power controller L, Lf, Lf1, Lfe

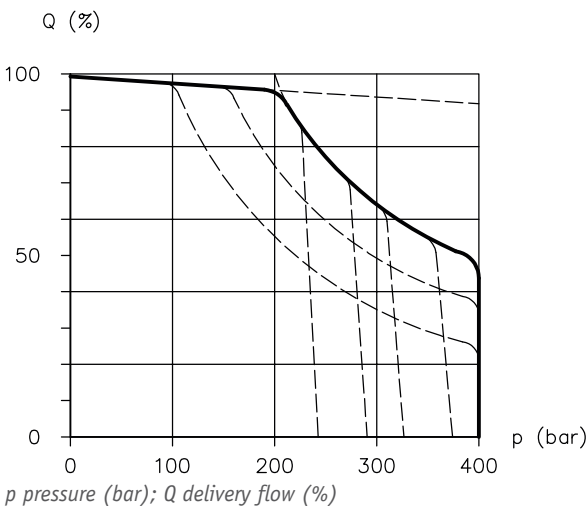

Coding	Drive torque (Nm)	Corresponds to kW / 1/min
095	99	15 / 1500
160	146	22 / 1500
270	300	45 / 1500

i INFORMATION
Lowest recommended nominal torque setting.

Lf

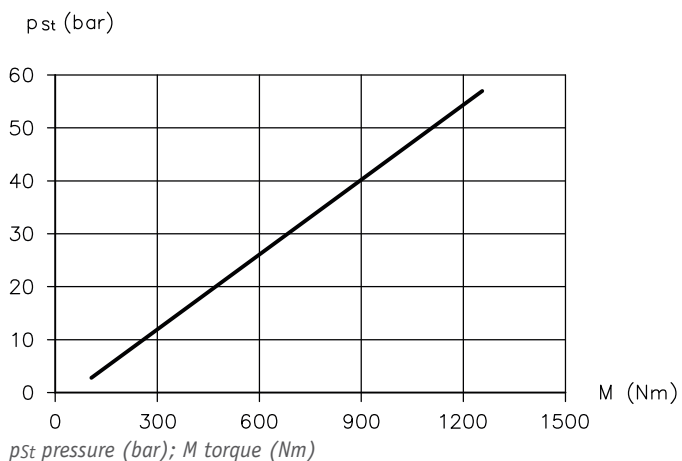

Lf1

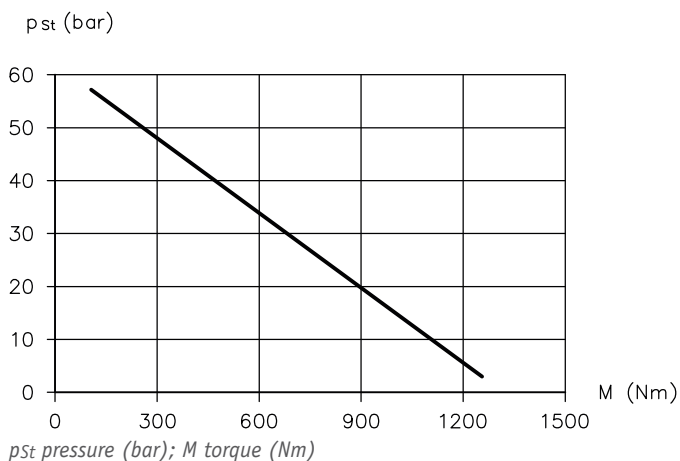

Flow controller EM..CH

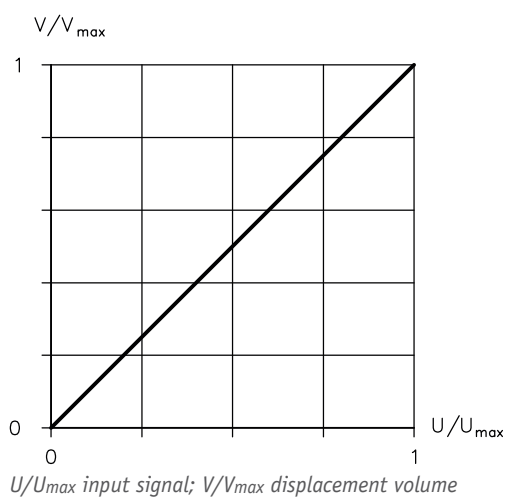

On-stroke time	270 ms -180 ms
Destroke time	130 ms to 100 ms
Hysteresis and linearity	1 %
Amplifier and controller board	Type DAC-4
- Supply voltage	18 to 30 V DC, residual ripple < 10%
- Target value inputs	0 to 10 V, 0 to 20 mA
Prop. directional valve	4/3-way directional valve NG 6

V controller

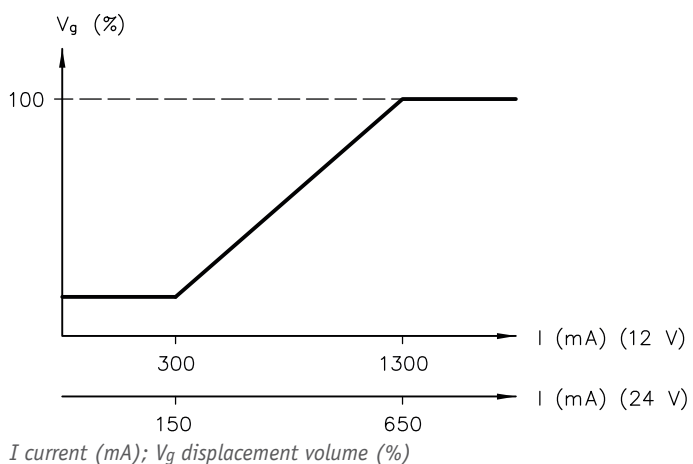

Shaft journal

Spline shaft

Coding **D**
(W45x2x21x9g DIN 5480)

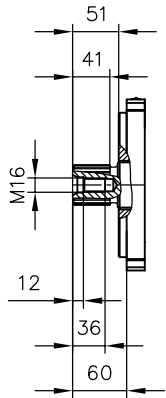

Spline shaft

Coding **S**
(SAE-D J 744 13T 8/16 DP)

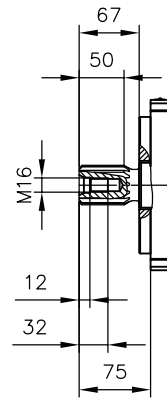

Parallel key shaft

Coding **K**
(Ø40 - 12x8x80 DIN 6885)

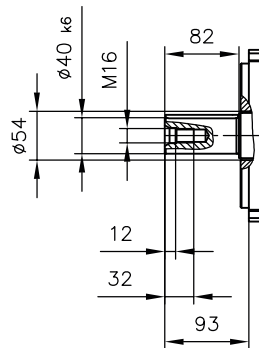

Flange version (input side)

Coding **G**
(160 B4 HW DIN ISO 3019-2)

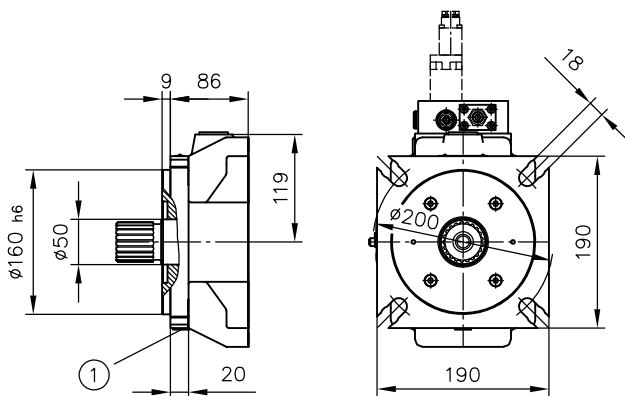

1 Venting and flushing port G 1/4

Coding **F**
(SAE-D 4-hole J 744)
(152-4 DIN ISO 3019-1)

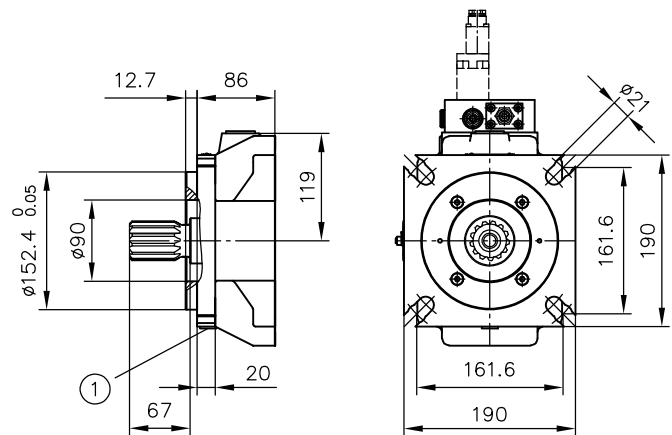

1 Venting and flushing port G 1/4

Thru-shaft

Housing version (radial ports, with thru-shaft)

V30E-095 ...-2

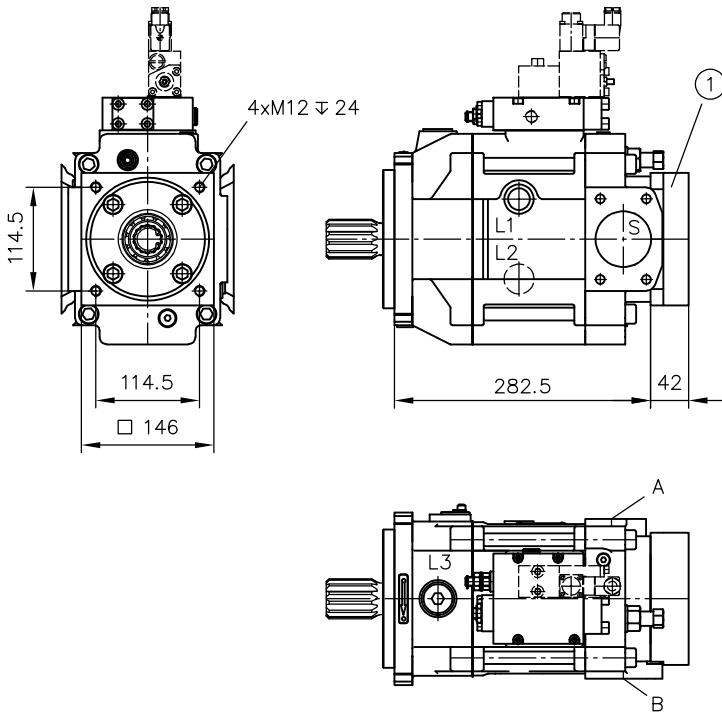

1 Flange version (output side)

**Rotation direction
clockwise**

A = pressure connection

B = suction port

**Rotation direction
anti-clockwise**

A = suction port

B = pressure connection

Flange version (output side)

Coding **C 211, C 212**

(SAE-A 2-hole J 744)

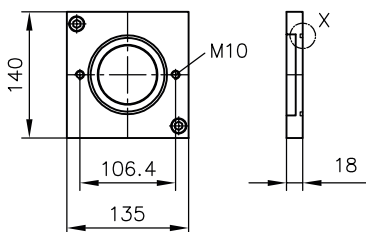

Coding **C 214, C 215**

(SAE-B 2-hole J 744, SAE-B 4-hole J 744)

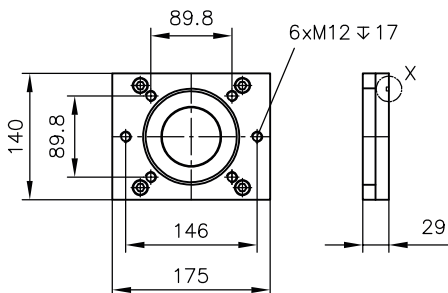

Coding **C 218**

(SAE-C 4-hole J 744)

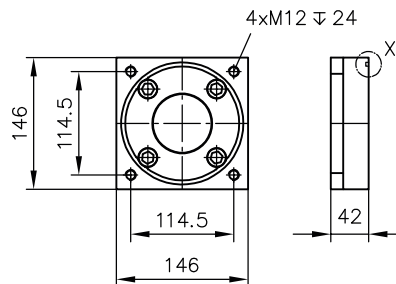

Coding **C 220**

(SAE-D 4-hole J 744)

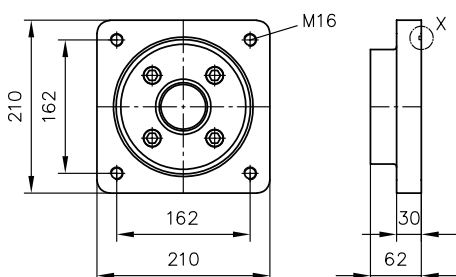

Coding **C 247**

Prepared for thru-shaft (cover)

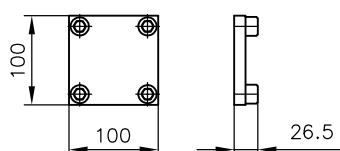

Detail X

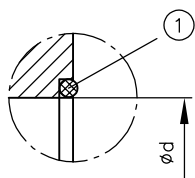

V30E-095	O-ring	$\varnothing d$
C 211, C 212	$\varnothing 84 \times 2$	$82.55^{+0.03}_{+0.01}$, 7 deep
C 214, C 215	$\varnothing 103 \times 2$	$101.6^{+0.03}_{+0.01}$, 11 deep
C 218, C 219	$\varnothing 132 \times 2$	$127^{+0.08}_{+0.04}$, 14 deep
C 220	$\varnothing 164 \times 3$	$152.4^{+0.08}_{+0.04}$, 14 deep

1 O-ring

O-ring included in scope of delivery

4.1.2 Type V30E-160

Rotation direction **clockwise** (viewed from shaft journal)

V30E-160, R

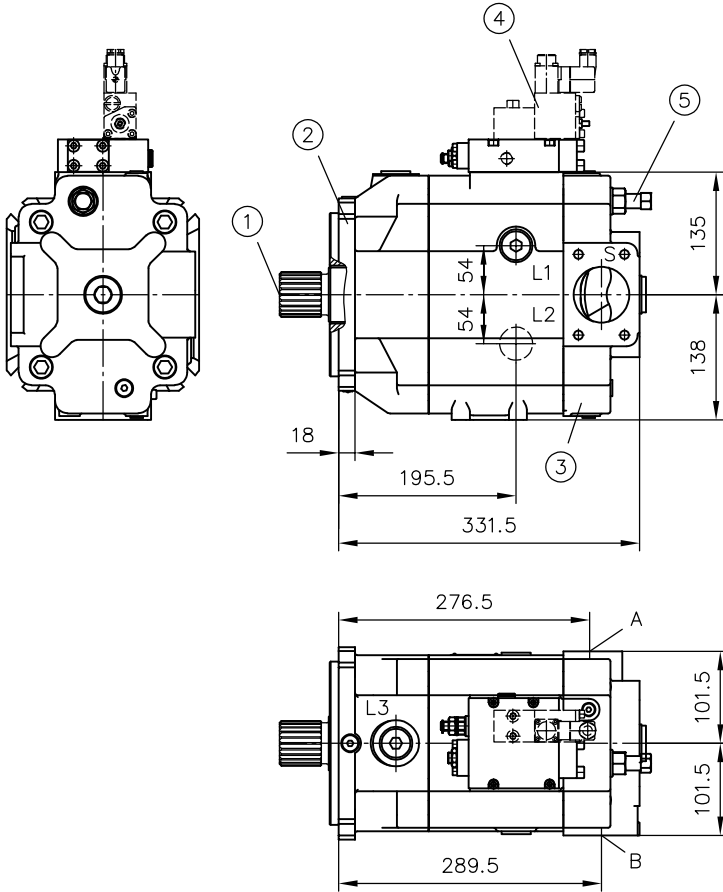

- 1 Shaft journal
- 2 Flange version
- 3 Thru-shaft
- 4 Controller
- 5 Stroke limitation (approx. 10 ccm/rev)

Rotation direction **anti-clockwise** (viewed from shaft journal)

V30E-160 L

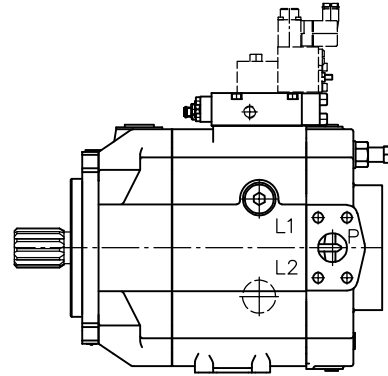

Drain ports	
L1, L2, L3	G 3/4
Rotation direction clockwise	Rotation direction anti-clockwise
A = pressure connection	A = suction port
B = suction port	B = pressure connection

Pressure connection

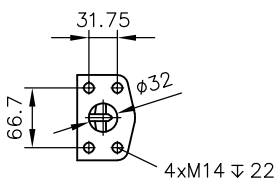

Suction port

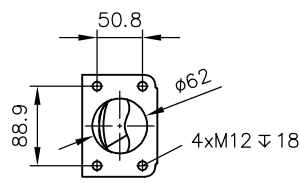

Shaft journal

Spline shaft

Coding **D**
(W50x2x24x9g DIN 5480)

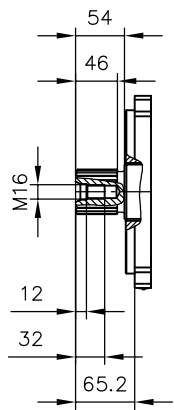

Spline shaft

Coding **S**
(SAE-D J 744 13T 8/16 DP)

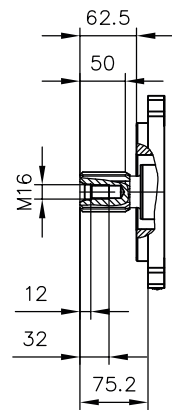

Parallel key shaft

Coding **K**
(Ø50 - 14x9x80 DIN 6885)

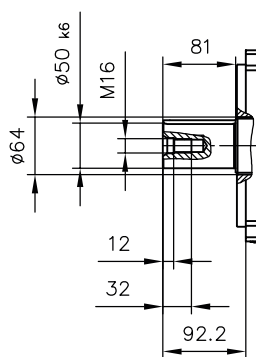

Flange version (input side)

Coding **G**
(180 B4 HW DIN ISO 3019-2)

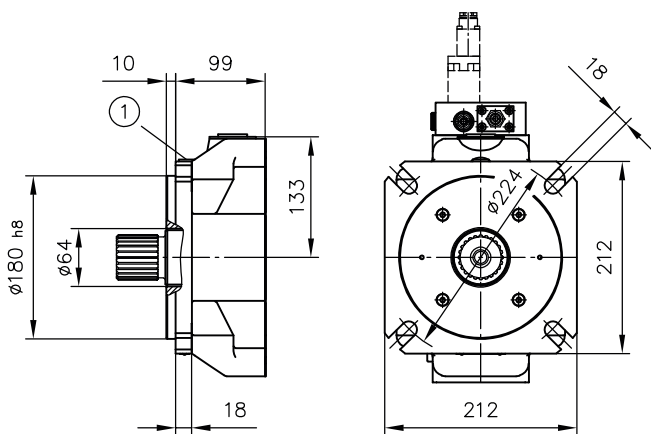

1 Venting and flushing port G 1/4

Coding **F**
(SAE-D 4-hole J 744)
(152-4 DIN ISO 3019-1)

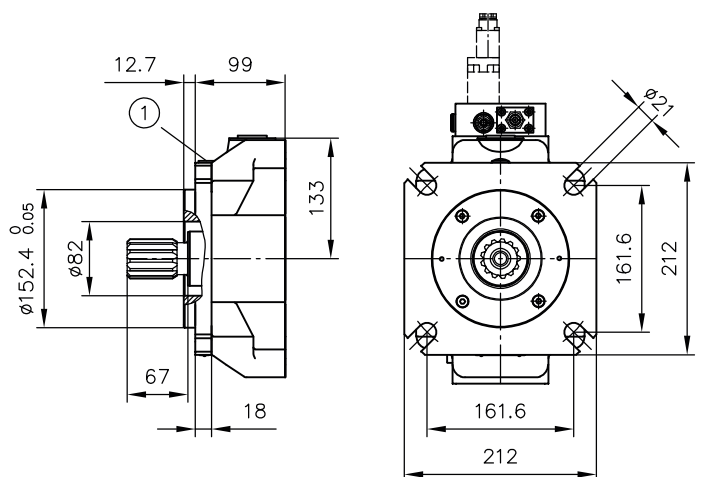

1 Venting and flushing port G 1/4

Thru-shaft

Housing version (radial ports, with thru-shaft)

V30E-160 ...-2

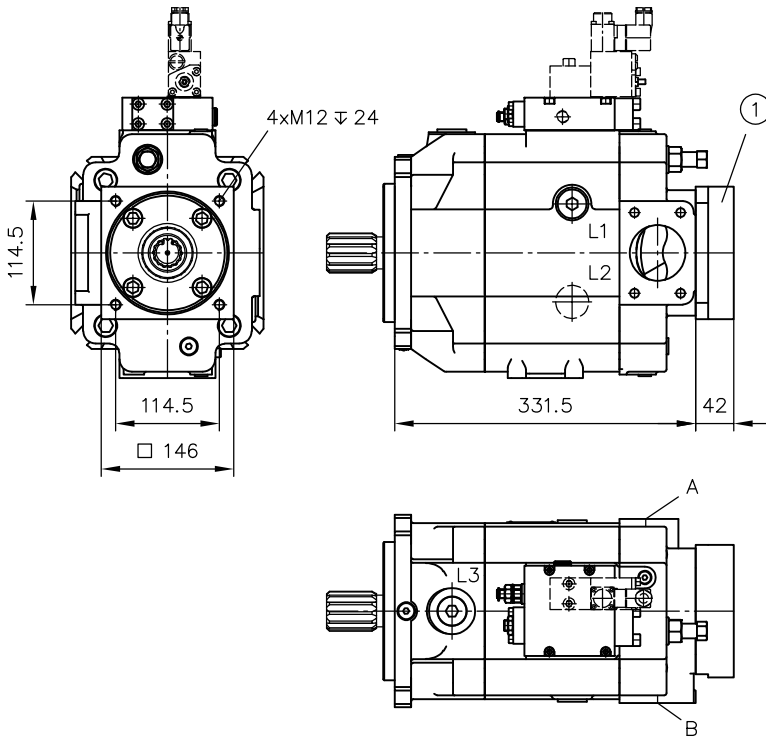

1 Flange version (output side)

Rotation direction clockwise	Rotation direction anti-clockwise
A = pressure connection	A = suction port
B = suction port	B = pressure connection

Flange version (output side)

Coding **C 221, C 222**

(SAE-A 2-hole J 744)

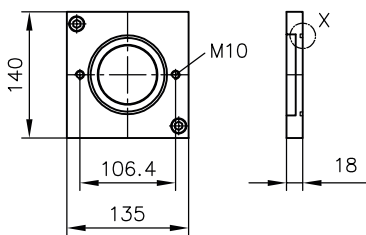

Coding **C 224, C 225**

(SAE-B 2-hole J 744, SAE-B 4-hole J 744)

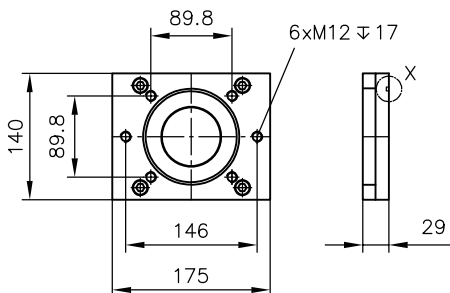

Coding **C 228**

(SAE-C 4-hole J 744)

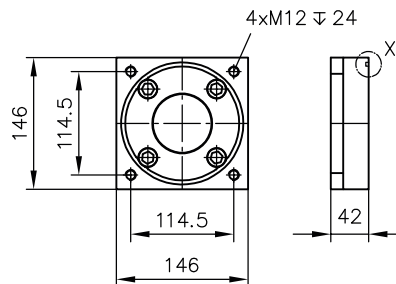

Coding **C 227**

(SAE-C 2-hole J 744)

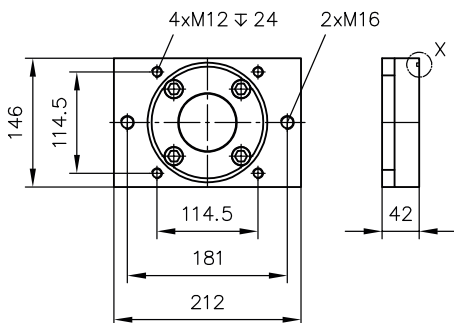

Coding **C 230**

(SAE-D 4-hole J 744)

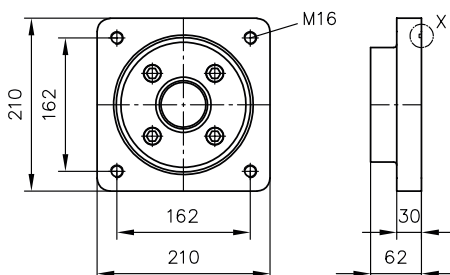

Coding **C 248**

Prepared for thru-shaft (cover)

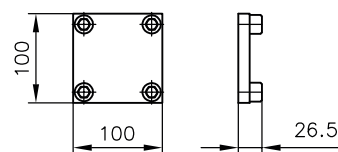

Detail X

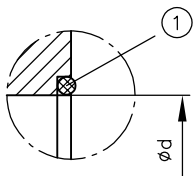

1 O-ring

O-ring included in scope of delivery

V30E-160	O-ring	$\varnothing d$
C 221, C 222	$\varnothing 84 \times 2$	$82.55^{+0.03}_{+0.01}$, 7 deep
C 224, C 225	$\varnothing 103 \times 2$	$101.6^{+0.03}_{+0.01}$, 11 deep
C 227, C 228	$\varnothing 132 \times 2$	$127^{+0.08}_{+0.04}$, 14 deep
C 230	$\varnothing 164 \times 3$	$152.4^{+0.08}_{+0.04}$, 14 deep

4.1.3 Type V30E-270

Rotation direction **clockwise** (viewed from shaft journal)

V30E-270, R

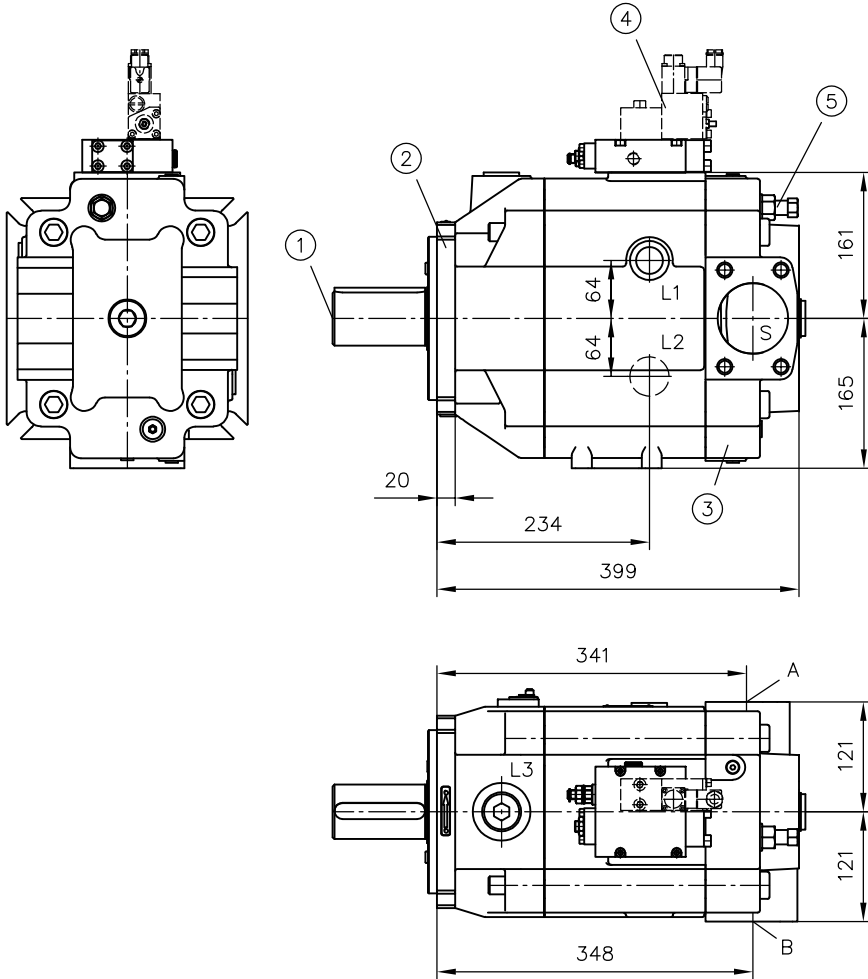

- 1 Shaft journal
- 2 Flange version
- 3 Thru-shaft
- 4 Controller
- 5 Stroke limitation (approx. 15 ccm/rev)

Rotation direction **anti-clockwise** (viewed from shaft journal)

V30E-270 L

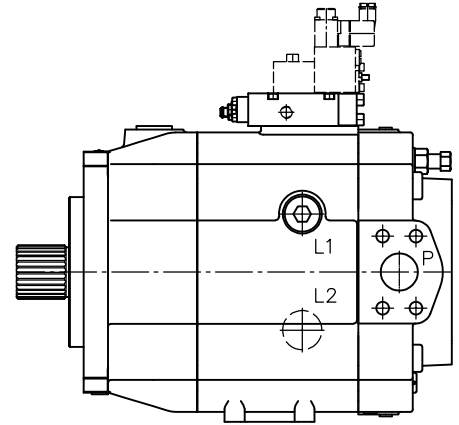

	Drain ports
L1, L2, L3	G 1
Rotation direction clockwise	Rotation direction anti-clockwise
A = pressure connection	A = suction port
B = suction port	B = pressure connection

Pressure connection

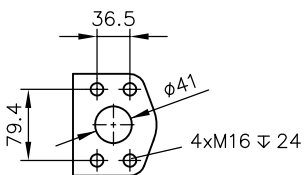

Suction port

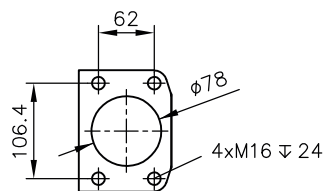

Shaft journal

Spline shaft

Coding **D**
(W60x2x28x9g DIN 5480)

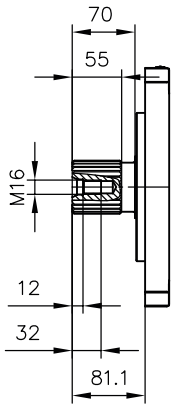

Spline shaft

Coding **S**
(17T 8/16 DP)

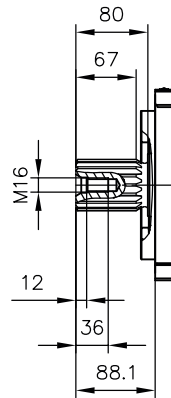

Spline shaft

Coding **U**
(SAE-D J 744)
(13T 8/16 DP)

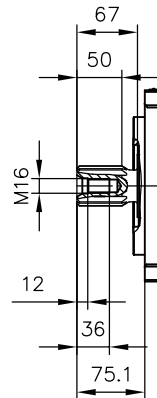

Parallel key shaft

Coding **K**
($\varnothing 60 - 18 \times 11 \times 100$ DIN 6885)

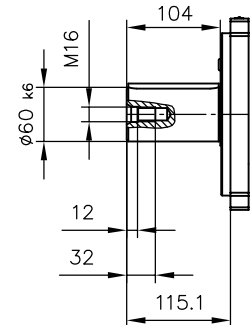

Flange version (input side)

Coding G
(180 B4 HW DIN ISO 3019-2)

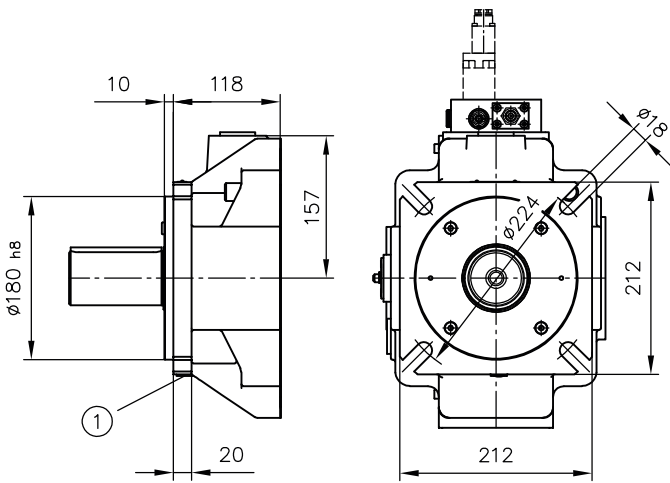

1 Venting and flushing port G 1/4

Coding F
(SAE-E 4-hole J 744)
(165-4 DIN ISO 3019-1)

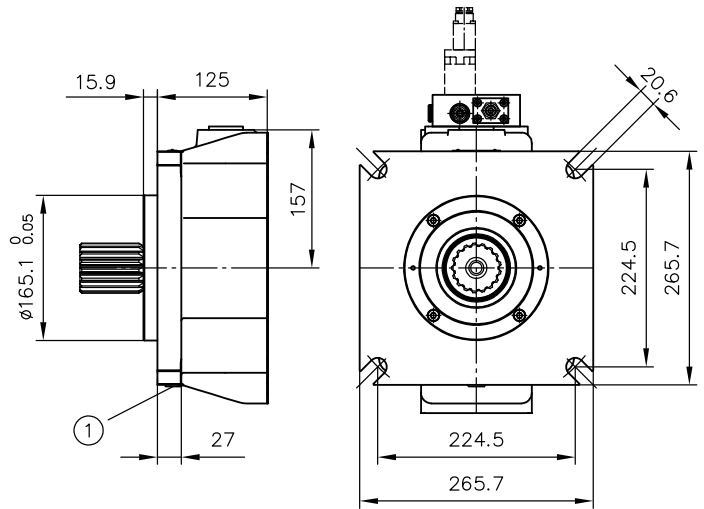

1 Venting and flushing port G 1/4

Coding W
(SAE-D 4-hole J 744)
(152-4 DIN ISO 3019-1)

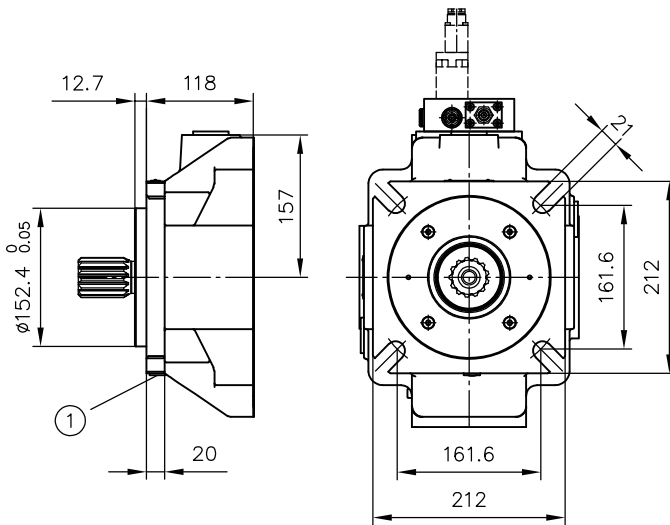

1 Venting and flushing port G 1/4

Thru-shaft

Housing version (radial ports, with thru-shaft)

V30E-270 ...-2

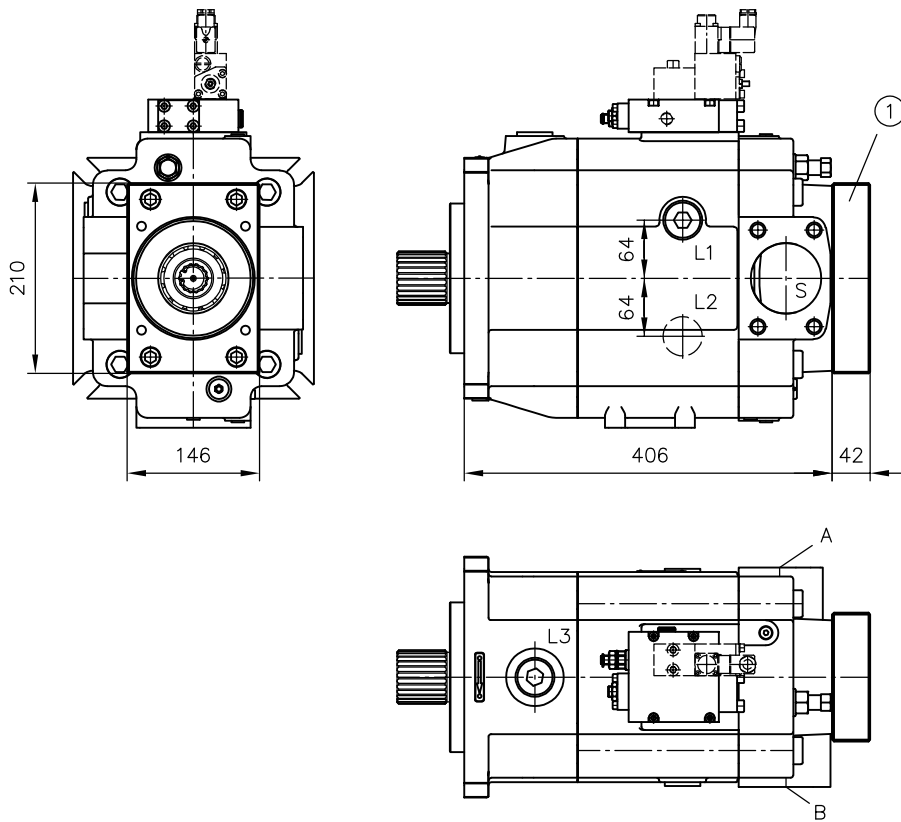

1 Flange version (input side)

Rotation direction clockwise	Rotation direction anti-clockwise
A = pressure connection	A = suction port
B = suction port	B = pressure connection

Flange version (output side)

Coding **C 231, C 232**
(SAE-A 2-hole J 744)

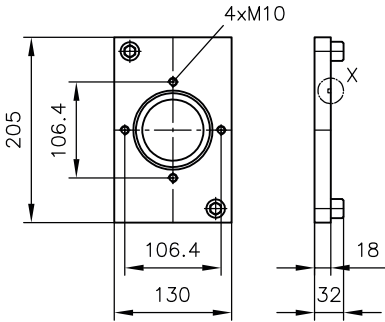

Coding **C 234**
(SAE-B 2-hole J 744)

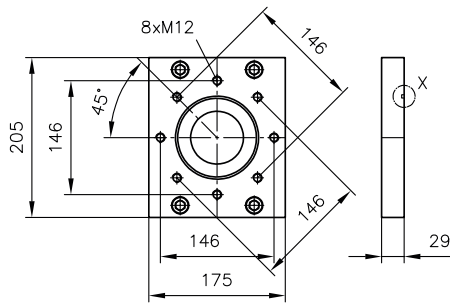

Coding **C 235**
(SAE-B 4-hole J 744)

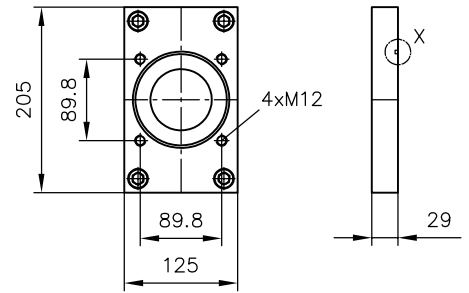

Coding **C 238**
(SAE-C 4-hole J 744 C 260)

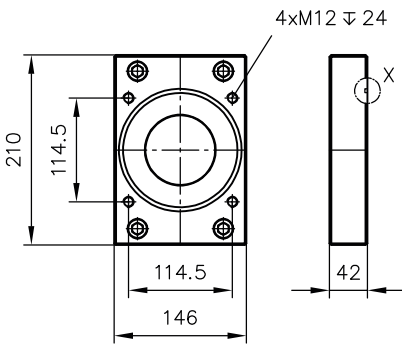

Coding **C 240**
(SAE-D 4-hole J 744)

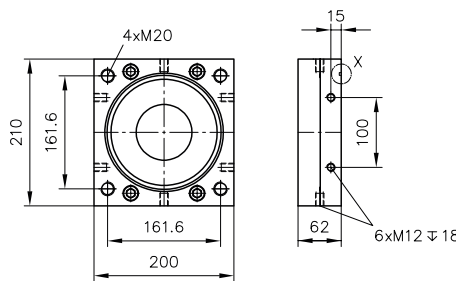

Coding **C 241**
(SAE-E 4-hole J 744)

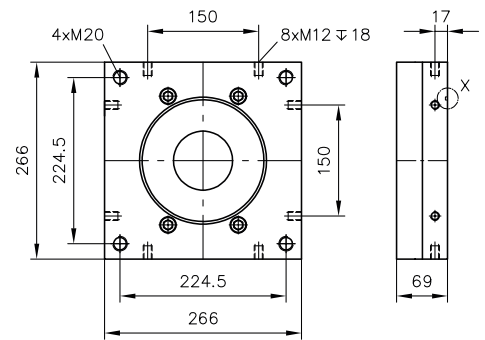

Coding **C 249**
Prepared for thru-shaft (cover)

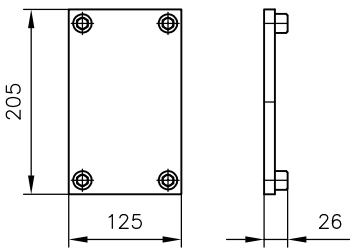

Detail X

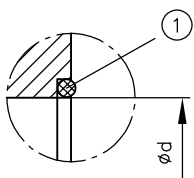

1 O-ring

V30E-270	O-ring	Ød
C 231, C 212	Ø84x2	82.55 +0.03+0.01, 7 deep
C 234, C 235	Ø103x2	101.6 +0.03+0.01, 11 deep
C 228	Ø132x2	127+0.08+0.04, 13 deep
C 240	Ø164x3	152.4 +0.08+0.04, 13 deep
C 241	Ø167x3	165.1+0.08+0.04, 16 deep

O-ring included in scope of delivery

4.2 Swivel angle indicator

Swivel angle indicator

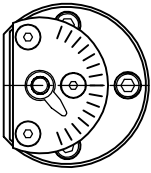

Swivel angle pick-up

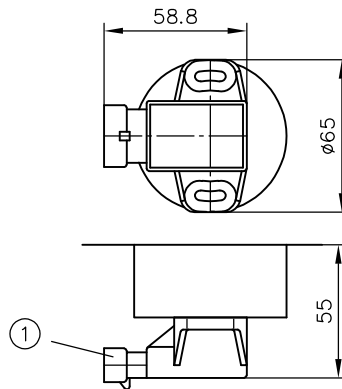

1 3-PIN AMP Superseal

4.3 Controllers

Coding P, LSP

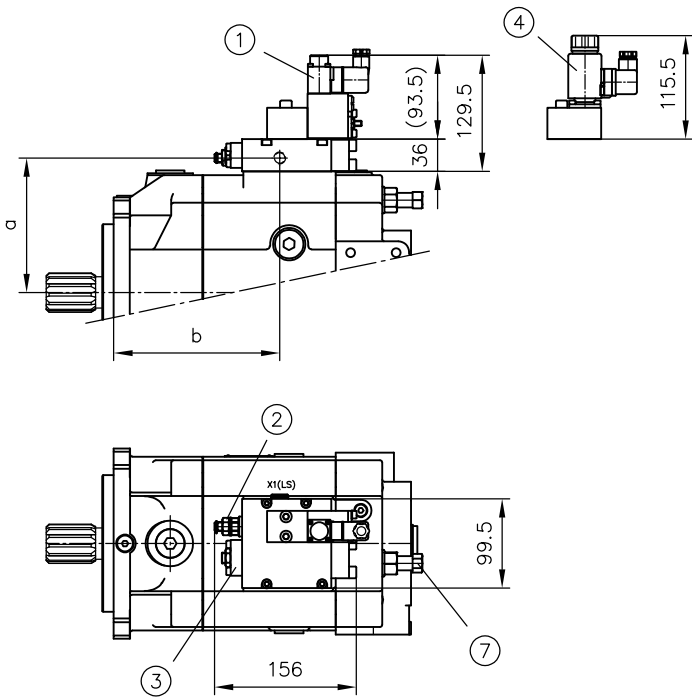

- 1 Prop. pressure-limiting valve type PMVPS 4 according to D 7485/1
- 2 Pressure controller setting
- 3 LSP: setting of LS stand-by pressure; P: setting of p_{min}
- 4 2/2-way directional seated valve type BVPM

Coding PL, LSPL

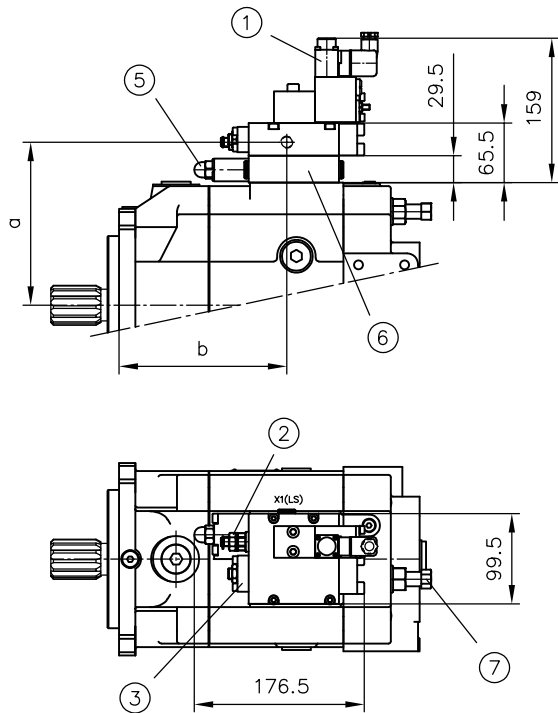

- 5 Power controller setting
- 6 Power controller (intermediate plate)
- 7 Stroke limitation setting

Connections (ISO 228-1)

LS, X1 G 1/4

⑤ Power controller setting:

	a	b	Power change (Nm)/revolution		a	b	Power change (Nm)/revolution
V30E-095	135	151	approx. 140	V30E-095	164,5	151	approx. 140
V30E-160	150	185	approx. 237	V30E-160	179,5	185	approx. 240
V30E-270	176	223,5	approx. 400	V30E-270	205,5	223,5	approx. 400

②③ Pressure controller setting:

Pressure adjustment	Pressure range (bar)	Δ p (bar)/revolution	Factory-set pressure setting (bar)
Maximum pressure p _{max}	20-350	approx. 50	300
Differential pressure Δ p	20-55	approx. 20	27

⑦ Stroke limitation setting:

	Stroke limitation (cm ³)/revolution
V30E-095	approx. 7.5
V30E-160	approx. 10.5
V30E-270	approx. 15

Coding **Pb, LSPb**

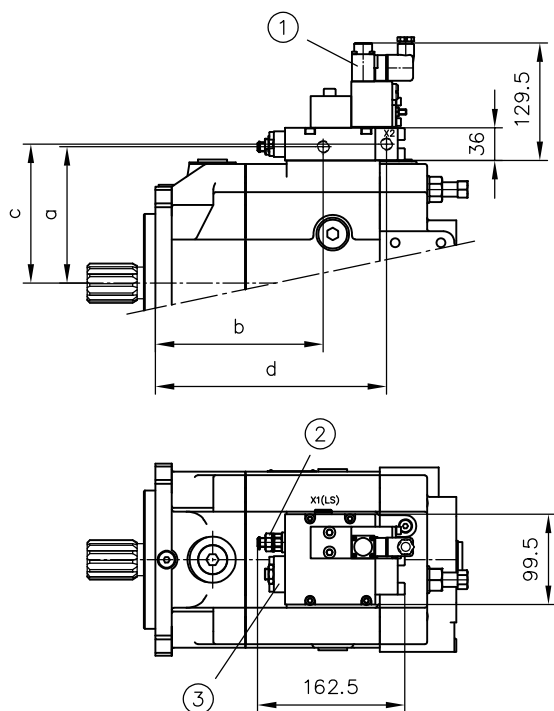

- 1 Prop. pressure-limiting valve type PMVPS 4 according to [D 7485/1](#)
- 2 Pressure controller setting
- 3 LSP: Adjustment of the LS stand-by pressure; N: setting of p_{min}

Connections (ISO 228-1)

LS, X1, X2 G 1/4

	a	b	c	d
V30E-095	135	151	138	220,75
V30E-160	150	185	153	254,75
V30E-270	176	223,5	179	293,25

Coding Lf, Lf1

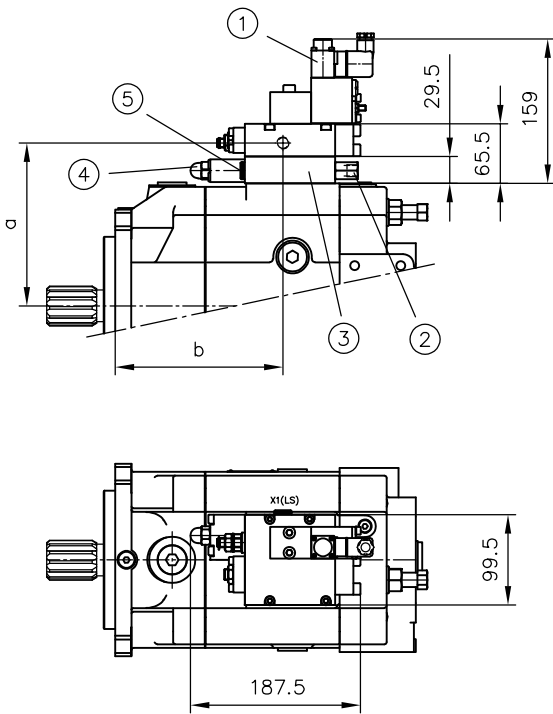

Coding Lfe

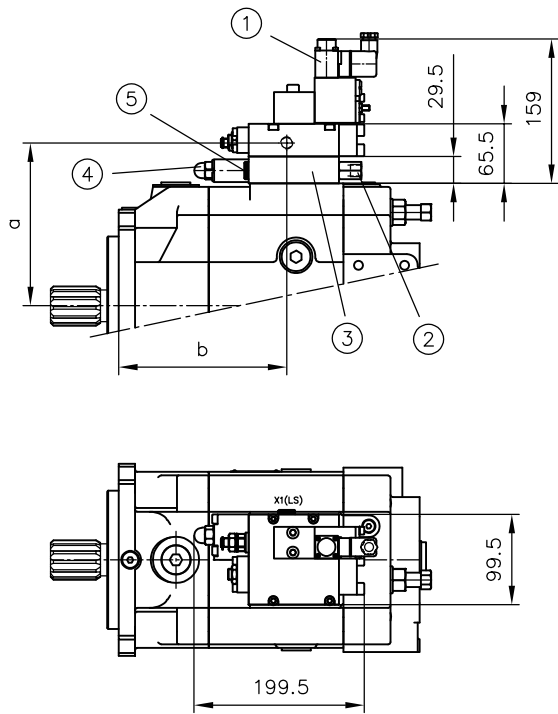

- 1 Prop. pressure-limiting valve type PMVPS 4 according to D 7485/1
- 2 Port f1 sealed in case of Lf
- 3 Power controller (intermediate plate)
- 4 Power controller setting
- 5 Port f sealed in case of Lf1

Ports (ISO 228-1)

LS, X1 G 1/4

⑤ **Power controller setting:**

	a	b	Power change (Nm)/revolution
V30E-095	164,5	151	140
V30E-160	179,5	185	240
V30E-270	205,5	223,5	400

Coding EM..., EML...

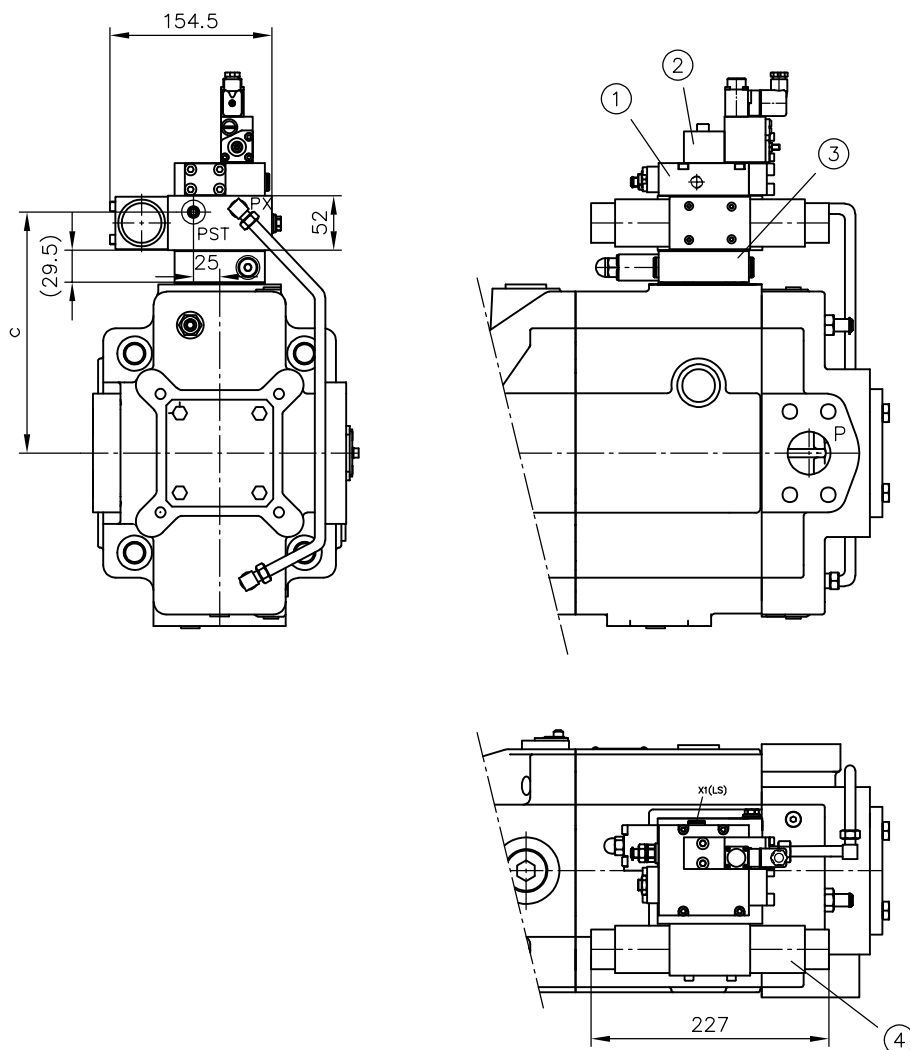

- 1 Pressure controller (option)
- 2 Prop. pressure-limiting valve type PMVPS 4 according to [D 7485/1](#)
- 3 Power controller (option)
- 4 Prop. directional spool valve

Connections (ISO 228-1)	
LS, X1	G 1/4
	c
V30E-095	156
V30E-160	169
V30E-270	197

Value "c": for version with power controller + 30 mm

⚠ CAUTION

Overloading components due to incorrect pressure settings.

Minor injuries. Flyaway or bursting parts and uncontrolled leakage of hydraulic fluid.

- Pay attention to the maximum operating pressure of the pump, valves and fittings.
- Always monitor the pressure gauge when setting and changing the pressure.

V controller

Coding V

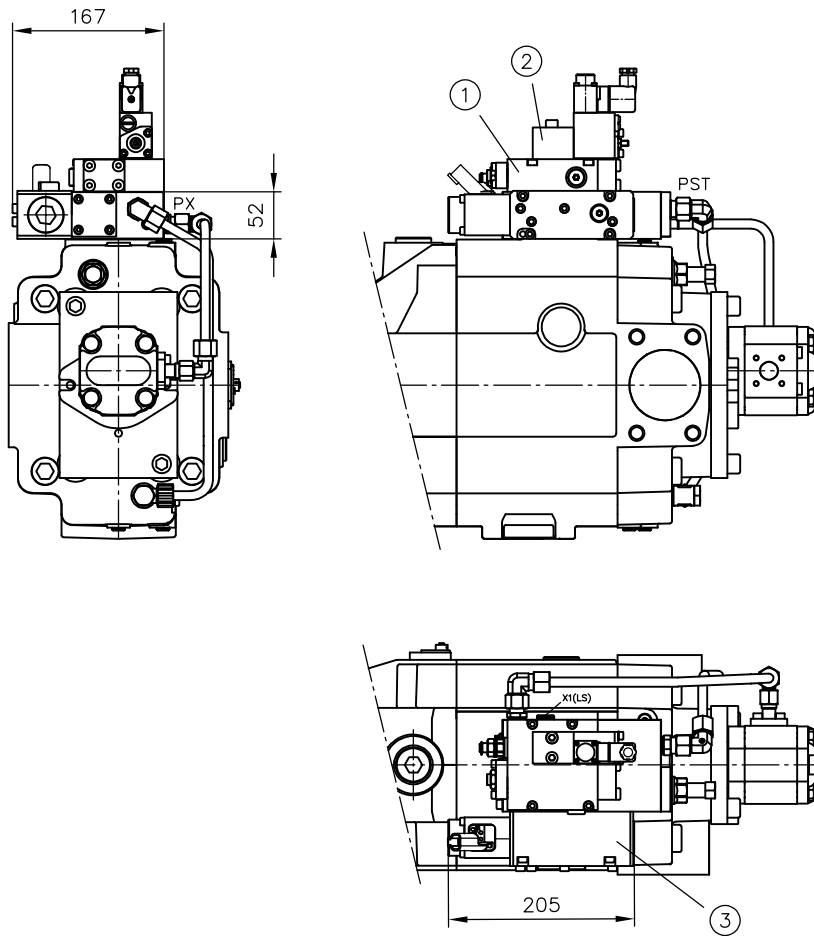

- 1 Pressure controller (option)
- 2 Prop. pressure-limiting valve type PMVPS 4 according to [D 7485/1](#)
- 3 Power controller (option)

Connections (ISO 228-1)

LS, X1	G 1/4
--------	-------

4.4 Pump combinations

4.4.1 Tandem pumps

A support is to be provided for pump combinations installed horizontally.

Two variable displacement axial piston pumps can be coupled together using an intermediate flange. The dimensioning of the shafts also permits the transmission of the full torque to the second pump.

All controller combinations are possible in the same way as for the single pumps.

Shaft versions "D" and "S" are available.

Available flange versions for tandem pumps, see Chapter 2.9, "Flange version (output side)"

Ordering example

V30E-270 RDFN-2-2-02/EMP/120-200-C257-

(1st pump)

V30E-160 RDGN-1-1-02/P/120-200

(2nd pump)

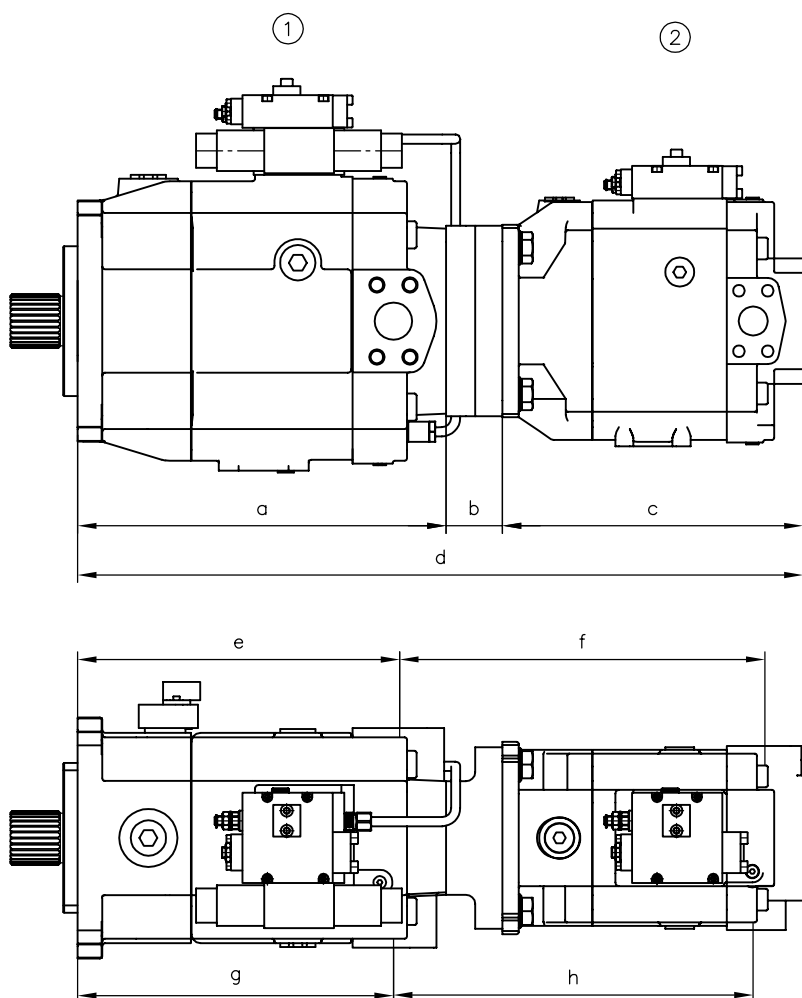

- 1 1st pump
- 2 2nd pump

1st pump	Coding	V30E-095 ..DG..-2-..-02								V30E-095 ..SF..-2-..-02							
2nd pump		a	b	c	d	e	f	g	h	a	b	c	d	e	f	g	h
V30E-095 ..DG..-1-..-02	C 250	282,5	47	296,5	625	252,5	329,5	239,5	329,5								
V30E-095 ..SF..-1-..-02	C 220									282,5	62	296,5	640	252,5	344,5	239,5	344,5

1st pump	Coding	V30E-160 ..DG..-2-..-02								V30E-160 ..SF..-2-..-02							
2nd pump		a	b	c	d	e	f	g	h	a	b	c	d	e	f	g	h
V30E-095 ..DG..-1-..-02	C 255	331,5	47	296,5	675	289,5	341,5	276,5	341,5								
V30E-095 ..SF..-1-..-02	C 230									331,5	62	296,5	690	289,5	356,5	276,5	256,5
V30E-160 ..DG..-1-..-02	C 257	331,5	52	344	727,5	289,5	383,5	276,5	383,5								
V30E-160 ..SF..-1-..-02	C 230									331,5	62	344	737,5	289,5	393,5	276,5	393,5

1st pump	Coding	V30E-270 ..DG..-2-..-02								V30E-270 ..SF..-2-..-02							
2nd pump		a	b	c	d	e	f	g	h	a	b	c	d	e	f	g	h
V30E-095 ..DG..-1-..-02	C 260	399	47	296,5	742,5	348	350,5	341	344,5								
V30E-095 ..SF..-1-..-02	C 240									406	62	296,5	764,5	355	365,5	348	359,5
V30E-160 ..DG..-1-..-02																	
V30E-160 ..SF..-1-..-02	C 240									406	62	344	812	355	402,5	348	396,5
V30E-270 ..DG..-1-..-02																	
V30E-270 ..SF..-1-..-02	C 241									406	69	413	888	355	475	348	475

4.4.2 Combination with gear pump

A gear pump can be added in the factory as an auxiliary or additional pump.

In the case of a pump with electro-hydraulic prop. adjustment (coding EM...) and an auxiliary pump, the piping is contained in the scope of delivery.

Ordering example

V30E-160 RKGN 2 -1 - XX / LSP / 280 - C 221 - Z 02-5

V30E basic pump

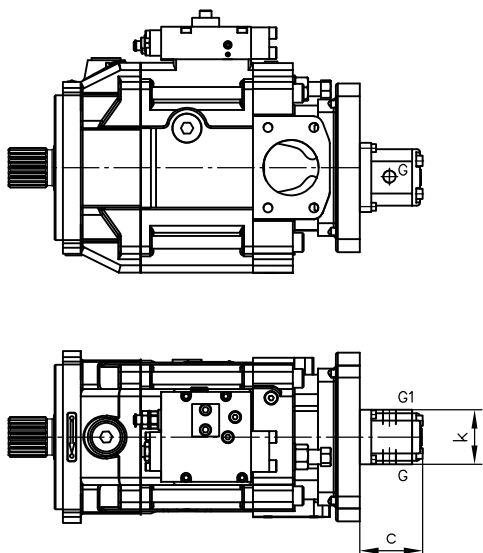

Coding	Displacement volume V_g (cm ³ /rev)	Auxiliary pump for	G	G1	c	k
Z 02-6	6,0	V30E-095	LK40/M6	LK35/M6	91	86
Z 02-9	8,40	V30E-160	LK40/M6	LK35/M6	95	86
Z 02-11	10,80	V30E-270	LK40/M6	LK35/M6	99	86

i INFORMATION

Auxiliary pump is required for the electro-hydraulic pump adjustment coding EM...

i INFORMATION

With EM a gear pump twice as large as the auxiliary pump can be used on tandem pumps.

i INFORMATION

Values "c" and "k" are reference values only.

Further key figures on request!

Observe the document B 5488 "General operating instructions for assembly, commissioning, and maintenance."

5.1 Intended use

This product is intended exclusively for hydraulic applications (fluid technology).

The user must observe the safety measures and warnings in this document.

Essential requirements for the product to function correctly and safely:

- ▶ All information in this documentation must be observed. This applies in particular to all safety measures and warnings.
- ▶ The product must only be assembled and put into operation by specialist personnel.
- ▶ The product must only be operated within the specified technical parameters described in detail in this document.
- ▶ All components must be suitable for the operating conditions when using an assembly.
- ▶ The operating instructions for the components, assemblies and the specific complete system must also always be observed.

If the product can no longer be operated safely:

1. Remove the product from operation and mark it accordingly.
 - ✓ It is then not permitted to continue using or operating the product.

5.2 Assembly information

The product must only be installed in the complete system with standard and compliant connection components (screw fittings, hoses, pipes, fixtures etc.).

The product must be shut down correctly prior to disassembly (in particular in combination with hydraulic accumulators).



DANGER

Sudden movement of the hydraulic drives when disassembled incorrectly

Risk of serious injury or death

- ▶ Depressurise the hydraulic system.
- ▶ Perform safety measures in preparation for maintenance.

5.2.1 General information

The variable displacement axial piston pump is suitable for use in an open circuit.

The pump can be mounted using a flange in accordance with specifications.

The various controllers can be fitted as intermediate plate versions or as separate devices as required.

During assembly, note the following principles:

- Only trained persons are allowed to mount or remove the pump.
- Always ensure absolute cleanliness to prevent contamination from affecting the pump.
- Remove all plastic plugs before operation.
- Avoid installation above the tank (see Chapter 5.2.3, "Installation positions").
- Observe the electric reference values.
- Before initial use, fill the pump with hydraulic fluid and bleed. Automatic pump filling via the suction line by opening the drain ports is not possible.
- Always supply the pump with hydraulic fluid from the start. Even just a short period with insufficient hydraulic fluid can damage the pump. Such damage is not immediately visible once the pump is put into operation.
- Never drain the pump.
- Hydraulic fluid which flows back into the tank must not be sucked back in immediately (install baffles!).

- Before first use, run the pump for approx. 10 minutes at max. 50 bar after initial start-up.
- Do not use the entire pressure range of the pump until it has been thoroughly bled and flushed.
- From the start, always keep the temperature within the specified range (see Chapter 3, "Parameters"). Never exceed the maximum temperature.
- Always comply with the cleanliness level of the hydraulic fluid. In addition, filter the hydraulic fluid appropriately (see Chapter 3, "Parameters").
- Self-installed filters in the suction line must be approved beforehand by HAWE Hydraulik.
- A system pressure-limiting valve must be installed in the pressure line so that the maximum system pressure is not exceeded.

5.2.2 Connections

The connecting lines' nominal width depends on:

- the given usage conditions
- Viscosity of the hydraulic fluid
- Start-up and operating temperature
- Pump speed

HAWE recommends: Use hose lines (improved damping characteristics) instead of rigid pipelines.

Bleeding and flushing port	<ul style="list-style-type: none"> ▪ The pump is fitted with a G 1/4" venting and flushing port. This is used to vent and flush the front shaft bearing in the case of vertical installation.
Pressure connection	<ul style="list-style-type: none"> ▪ The pressure connection is established via SAE ports, see Chapter 4, "Dimensions". Metric mounting threads are used in deviation from the standard. ▪ Observe the fitting manufacturers' specified tightening torques.
Suction port	<ul style="list-style-type: none"> ▪ The suction port uses SAE ports, see Chapter 4, "Dimensions". Metric mounting threads are used in deviation from the standard. ▪ If possible, route the suction line to the tank on a rising gradient. This allows trapped air to escape. ▪ The absolute suction pressure must not fall below 0.85 bar. ▪ A hose line should generally be used in preference to a rigid pipe line.
Drain port	<ul style="list-style-type: none"> ▪ The pump features 3 drain ports G 3/4" or G 1". ▪ The nominal width of the leakage line must not be less than 16 mm. The cross-section is determined by the max. permissible housing pressure. ▪ Integrate the leakage line in the system in such a way as to prevent direct connection with the suction line of the pump. ▪ All drain ports can be used simultaneously. ▪ A separate leakage line from the controller to the tank is not required. Observe the specifications in Chapter 5.2.3, "Installation positions". ▪ The top drain port can be used to fill the housing.
LS port on LSP version	<ul style="list-style-type: none"> ▪ The LS line is connected to the controller via a G 1/4" threaded connection. ▪ The nominal width of the line depends on the mounting position of the pump and should be 10% of the pressure line capacity. A hose line should generally be used in preference to a rigid pipe connection. ▪ When the proportional directional spool valves are in neutral position, the LS line must always be fully relieved!
For operation with HFC (35 - 50 % water content) the following restrictions apply	<ul style="list-style-type: none"> ▪ tank located above pump ▪ temperature does not exceed 50°C ▪ fluid rate in suction line is less than 1 m/s ▪ pump pressure no more than 200 bar ▪ each of a pump's two shaft bearings are flushed by a separate supply of cool oil, at 3 l/min per bearing (V30E-095), 4 l/min (V30E-160) and 5 l/min (V30E-270)

For operation with liquids with a water content $\leq 20\%$ the following restrictions apply

- tank located above pump
- tank temperature does not exceed 70°C
- fluid rate in suction line is less than 1 m/s
- pump pressure no more than 300 bar
- possible without bearing flushing

5.2.3 Installation positions

The variable displacement axial piston pump can be mounted in any installation position.

A support is required for tandem pumps or multiple hydraulic pumps mounted in series (see Chapter 5.2.1, "General information").

Horizontal installation

Pump below the min. fill level

- ▶ For horizontal installation, use the uppermost drain port.

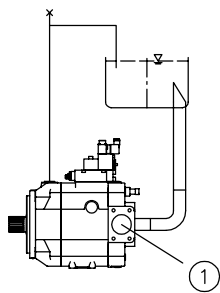

1 Suction port open

Vertical installation

Pump below the min. fill level

- ▶ Mount the pump so that the pump mounting flange is facing upwards.
- ▶ For vertical installation, use the uppermost drain port.
- ▶ Also connect the G 1/8" venting port to the pump flange (see Chapter 4, "Dimensions").
- ▶ Take appropriate measures to ensure continuous venting of this line (line routing/venting).

For installation with pump flange facing downwards: Get in touch with HAWE Hydraulik SE.

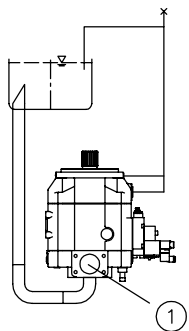

1 Suction port open

5.2.4 Tank installation

Pump below the min. fill level

The pump can be operated either with or without a suction intake. Using a short suction intake is recommended.

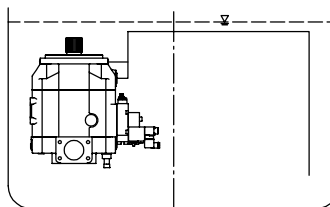
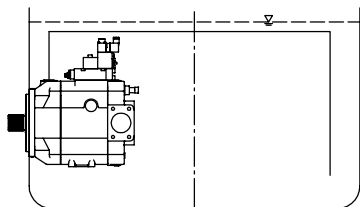

Pump above the fill level

! NOTICE

The pump must not run dry via the pressure, intake, drain, venting or control lines. This applies in particular to long periods of downtime.

- ▶ The leakage line must be installed in the tank in such a way that it ends below the oil level.
- ▶ Facilitate venting of connecting lines via separate vent openings.
- ▶ Adjust the venting sequence to suit the specific installation.
- ▶ If necessary, a gear pump should be provided in order to draw air from the suction line.

Contact form for special consultation on axial piston pump design:

Checklist for variable displacement axial piston pump design: B 7960 checklist

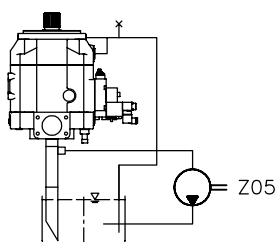
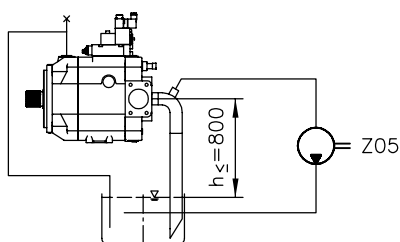

For further information on installation, operation and maintenance, see the relevant assembly instructions: [B 7960](#), [B 5488](#).

5.3 Operating instructions

Observe product configuration and pressure/flow rate.

The statements and technical parameters in this document must be strictly observed.
The instructions for the complete technical system must also always be followed.

NOTICE

- ▶ Read the documentation carefully before usage.
- ▶ The documentation must be accessible to the operating and maintenance staff at all times.
- ▶ Keep documentation up to date after every addition or update.

CAUTION

Overloading components due to incorrect pressure settings.

Minor injuries. Flyaway or bursting parts and uncontrolled leakage of hydraulic fluid.

- Pay attention to the maximum operating pressure of the pump, valves and fittings.
- Always monitor the pressure gauge when setting and changing the pressure.

Purity and filtering of the hydraulic fluid

Fine contamination can significantly impair the function of the product. Contamination can cause irreparable damage.

Examples of fine contamination include:

- Swarf
- Rubber particles from hoses and seals
- Dirt due to assembly and maintenance
- Mechanical debris
- Chemical ageing of the hydraulic fluid

NOTICE

New hydraulic fluid from the manufacturer may not have the required purity.

Damage to the product is possible.

- ▶ Filter new hydraulic fluid to a high quality when filling.
- ▶ Do not mix hydraulic fluids. Always use hydraulic fluid that is from the same manufacturer, of the same type, and with the same viscosity properties.

For smooth operation, pay attention to the cleanliness level of the hydraulic fluid (cleanliness level see Chapter 3, "Parameters").

Additionally applicable document: [D 5488/1](#) oil recommendations

5.3.1 Limitations

For operation with HFC (35 - 50% water content) the following restrictions apply

- tank located above pump
- temperature does not exceed 50°C
- fluid rate in suction line is less than 1 m/s
- pump pressure no more than 200 bar
- each of a pump's two shaft bearings are flushed by their own separate, cool oil, at 2 l/min per bearing (V30D-045/075), 3 l/min per bearing (V30E-095), 4 l/min per bearing (V30E-160) and 5 l/min per bearing (V30E-270)

For operation with liquids with a water content $\leq 20\%$ the following restrictions apply

- tank located above pump
- tank temperature does not exceed 70°C
- fluid rate in suction line is less than 1 m/s
- pump pressure no more than 300 bar
- possible without bearing flushing

5.4 Maintenance information

This product is largely maintenance-free.

Check regularly (at least once a year) by visual inspection whether the hydraulic connections are damaged. If external leakages are found, shut down and repair the system.

Clean the surface of the device regularly (at least once a year) (dust deposits and dirt).

6 Other information

6.1 Planning information

Determination of nominal sizes

Delivery flow	$Q = \frac{V_g \cdot n \cdot \eta_V}{1000} \text{ (l/min)}$	Q = Flow rate (l/min)
Drive torque	$M = \frac{V_g \cdot \Delta p}{20 \cdot \pi \cdot \eta_{mh}} \text{ (Nm)}$	M = Torque (Nm)
Drive power	$P = \frac{2\pi \cdot M \cdot n}{60000} = \frac{Q \cdot \Delta p}{600 \cdot \eta_t} \text{ (kW)}$	P = Power (kW)
		V _g = Geom. output volume (cm ³ /rev)
		Δp = Differential pressure
		n = Speed (min ⁻¹)
		η _v = Volumetric efficiency
		η _{mh} = Mechanical-hydraulic efficiency
		η _t = Overall efficiency (η _t = η _v · η _{mh})

References

Additional versions

- Variable displacement axial piston pump type V60N: D 7960 N
- Variable displacement axial piston pump type V30D: D 7960
- Variable displacement axial piston pump type C41V: D 7964/1
- Fixed displacement axial piston pump type K60N: D 7960 K
- Axial piston motors type M60N: D 7960 M
- Proportional directional spool valve type PSL, PSV size 2 and EDL: D 7700-2
- Proportional directional spool valves types PSL/PSV/PSM, size 3: D 7700-3
- Proportional directional spool valves type PSL, PSV, PSM, size 5: D 7700-5
- Proportional directional spool valve type PSLF, PSVF and SLF size 3: D 7700-3F
- Proportional directional spool valve banks type PSLF, PSVF size 5: D 7700-5F
- Proportional directional spool valve banks type PSLF and PSVF size 7: D 7700-7F
- Load-holding valve type LHT: D 7918
- Load-holding valve type CLHV: D 7918-VI-C
- Load-holding valve type CLHV: D 7918-VI-PIB
- Load-holding valve type LHDV: D 7770
- Proportional amplifier type EV1M3: D 7831/2
- Proportional amplifier type EV1D: D 7831 D
- Proportional amplifier type EV2S: D 7818/1

Operating instructions

- General operating manual for the assembly, initial operation and maintenance of hydraulic components and systems: B 5488

