

# Valve bank (nominal size 6) type BA

## Product documentation

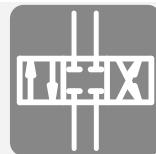

Operating pressure  $p_{\max}$ :

400 bar

Flow rate  $Q_{\max}$ :

30 l/min

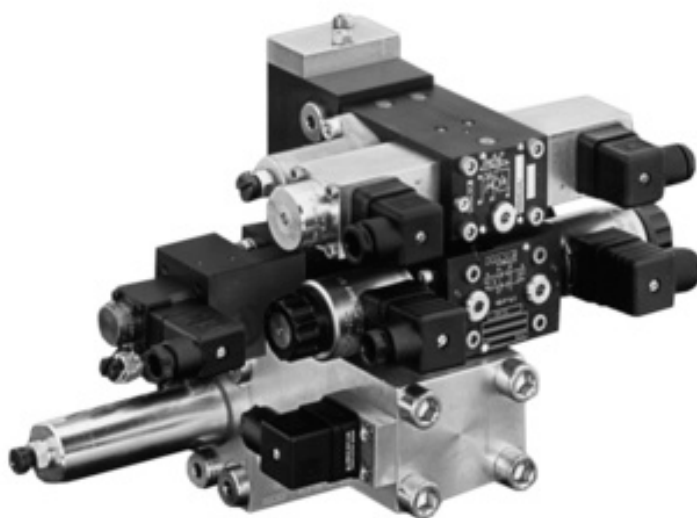

© by HAWE Hydraulik SE.

The reproduction and distribution of this document, as well as the use and communication of its contents to others without explicit authorization, is prohibited.

Offenders will be held liable for the payment of damages.

All rights reserved in the event of patent or utility model applications.

Brand names, product names and trademarks are not specifically indicated. In particular with regard to registered and protected names and trademarks, usage is subject to legal provisions.

HAWE Hydraulik respects these legal provisions in all cases.

HAWE Hydraulik cannot provide individual guarantees that the stated circuits or procedures (including in part) are not subject to the intellectual property rights of third parties.

Printing date / document generated on: 2024-10-08

## Table of Contents

<b>1</b>	<b>Overview of valve bank (nominal size 6) type BA.....</b>	<b>4</b>
<b>2</b>	<b>Available versions.....</b>	<b>5</b>
2.1	Basic type and size.....	5
2.2	Connection block.....	6
2.3	Valve sections.....	7
2.3.1	Directional valves.....	7
2.3.2	Sub-plates.....	11
2.3.3	Sub-plate additional elements.....	13
2.4	Intermediate plates.....	14
2.4.1	Pressure reducing valves in the P channel.....	16
2.4.2	Intermediate plate for a 2nd Speed.....	18
2.4.3	Intermediate plate with proportional pressure-limiting valve for second pressure circuit in BA valve bank.....	20
2.4.3.1	Solenoid voltage and solenoid male connector for proportional solenoid.....	21
2.5	End plates.....	22
2.6	Solenoid voltage and connector.....	24
<b>3</b>	<b>Parameters.....</b>	<b>25</b>
3.1	General data.....	25
3.2	Pressure and volumetric flow.....	25
3.3	Weight.....	26
<b>4</b>	<b>Dimensions.....</b>	<b>27</b>
4.1	Connection block.....	27
4.2	Valve sections.....	28
4.2.1	Sub-plates.....	28
4.2.2	Reactive plates.....	32
4.2.3	Intermediate plates.....	33
4.2.4	Pressure reducing valves.....	34
4.2.5	Intermediate plates for a 2nd Speed.....	38
4.2.6	Pressure-limiting valves.....	38
4.2.7	Proportional pressure-limiting valves.....	39
4.3	End plates.....	39
<b>5</b>	<b>Installation, operation and maintenance information.....</b>	<b>46</b>
5.1	Intended use.....	46
5.2	Assembly information.....	46
5.2.1	Maximum adjustment travel of the throttle screw.....	46
5.3	Operating instructions.....	47
5.4	Maintenance information.....	48
<b>6</b>	<b>Other information.....</b>	<b>49</b>
6.1	Circuit example.....	49
6.2	Accessories, spare and individual parts.....	50

**1****Overview of valve bank (nominal size 6) type BA**

A valve bank combines different valves for operating independent consumers.

The directional valve bank type BA connects individual valve sections using sub-plates, thus enabling compact hydraulic manifolds to be assembled flexibly. Depending on what is required for the individual functions, it is possible to combine directional seated valves and directional spool valves in the bank.

The intermediate plates type NZP enable additional functions and contain, for example, pressure reducing valves, shock valves, load-holding valves etc. An intermediate plate can be inserted between the sub-plate and the directional valve. The valve bank can be directly flange-mounted to compact hydraulic power packs or used separately with a pipe connection.

**Features and advantages**

- Flexible combination of directional valves with standard connection pattern NG 6 (Cetop 3)
- Can be mounted directly to hydraulic power packs
- Hydraulic accumulator can be mounted directly

**Intended applications**

- Machine tools (cutting and non-cutting)
- Clamping tools, punching tools, fixtures

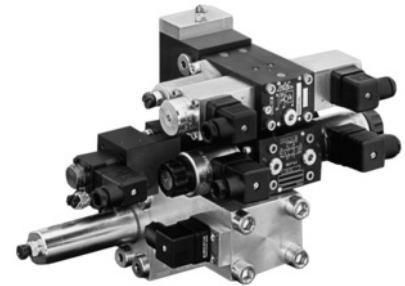

*Valve bank (nominal size 6) type BA*

## 2 Available versions

### Ordering examples

BA 2	A5	-NBVP 16 G -NSWP 2 D03/MP/NZP 16 Q33 -CZ 5R/120/5R -NBVP 16 G/ABR0,8 BBR1,0/M	/3 /1 /0	-MAX 84 Z -MBX 84 G	-1	-G 24
------	----	--	----------------	---------------------	----	-------

2.1 "Basic type and size"

2.2 "Connection block"

- 2.3 "Valve sections"
- 2.4 "Intermediate plates"

2.3.2 "Sub-plates"

2.3.3 "Sub-plate additional elements"

2.5 "End plates"

2.6 "Solenoid voltage and connector"

### 2.1 Basic type and size

Type	Description	Flow rate $Q_{\max}$ (l/min)	Pressure $p_{\max}$ (bar)	Return line pressure $p_{\max}$ (bar)
BA 2	for directional valves NG 6 (ISO 4401-03, CETOP 03) and others	30	400	50

#### ! NOTICE

Observe the specifications of the attached directional valves and upstream hydraulic power packs.

## 2.2 Connection block

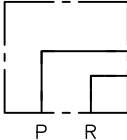
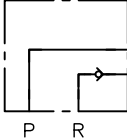
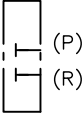
Coding	Description	Connection P, R	Circuit symbol
<b>Without coding</b>	Direct mounting on connection blocks of type AB (D 6905 AB) for combination with compact hydraulic power packs of type KA 2 (D 8010), KA 4 (D 8010-4), HK (D 7600 and onwards), MPN (D 7207), INKA 1 (D 8132-1)	--	-
<b>A5</b>	Version for pipe connection	G 3/8	
<b>A8</b>	Version for pipe connection, additional check valve in R	G 3/8	
<b>A9 A91 A92</b>	End plate, if P and R connection takes place via an intermediate segment or the end plate Coding .1 with space for one valve section to be mounted later Coding .2 with space for two valve sections to be mounted later	--	

## 2.3 Valve sections

### 2.3.1 Directional valves

Coding	Description	Flow rate $Q_{max}$ (l/min)	Pressure $p_{max}$ (bar)	Document
<b>Directional valves NG 6</b>				
<b>Can be combined with intermediate plates type NZP to D 7788 Z</b>				
NSWP 2	3/2, 3/3, 4/2 and 4/3 directional spool valve with additional options (pressure monitoring, restrictors and restrictor check valves in the ports)	25	315	D 7451 N
CWPN 06	4/2 and 4/3 directional spool valve with additional options (orifices, check valves in the ports and hand lever emergency override)	30	350	D 7451 CWPN
SWPM 06	4/2 and 4/3 directional spool valve with position switch	30	350	D 6420/1
POL	4/2 and 4/3 directional spool valve, proportional, without position switch	30	350	D 6394
PRL, PIL, PIH	4/2 and 4/3 directional spool valve, proportional, with position switch	30	350	D 6394 D 6418
NSMD 2	Clamping module (combination of 4/2 or 4/3 directional spool valve, pressure reducing valve and tracked pressure switch)	25	100	D 7787
ROLV 14	3/2, 4/2 and 4/3 directional seated valves	25	400	D 8144
NBVP 16	2/2, 3/2, 3/3, 4/2, 4/3 and 4/4 directional seated valves	20	400	D 7765 N
<p><b>i INFORMATION</b></p> <p>In contrast to the designation of a single valve to D 7765 N, a coding for the actuation must also be specified (M solenoid - 400 bar; GM solenoid - 250 bar; H - hydraulic; P - pneumatic; A - hand lever)</p>				
NBMD 16	Brake module (combination of directional seated valves and preloaded reflux)	20	400	Sk 7983 ++
NPMVP	Proportional pressure-limiting valve	16	(400)	D 7485 N
NG 6X	Reactive plate (for subsequent installation of a directional valve)			
NG 6X PA	Reactive plate with short circuit connection from P to A			
NG 6X PB	Reactive plate with short circuit connection from P to B			
NG 6X AT	Reactive plate with short circuit connection from A to T			
NG 6X PA 22	Reactive plate with connections			

Coding	Description	Flow rate $Q_{max}$ (l/min)	Pressure $p_{max}$ (bar)	Document
<b>Directional valves</b>				
SP 1	manually operated directional spool valve, only in combination with sub-plate coding /9	12	400	D 5650/1
<b>Pressure reducing valve in P channel, suitable for type BNG 2</b>				
ADM 33 P	Pressure reducing valve	60	320	D 7120

**Circuit examples for directional valves sub-plates**

NSWP 2 G/M/R/ABV1.0 BBV1.5/70/S/3

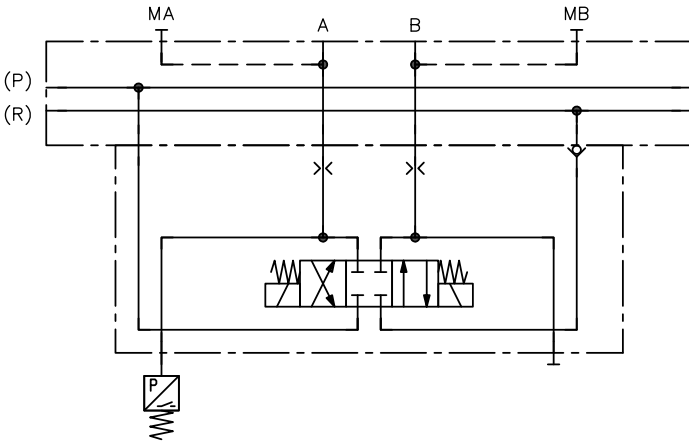

NSWP 2 D06/MP/20/3

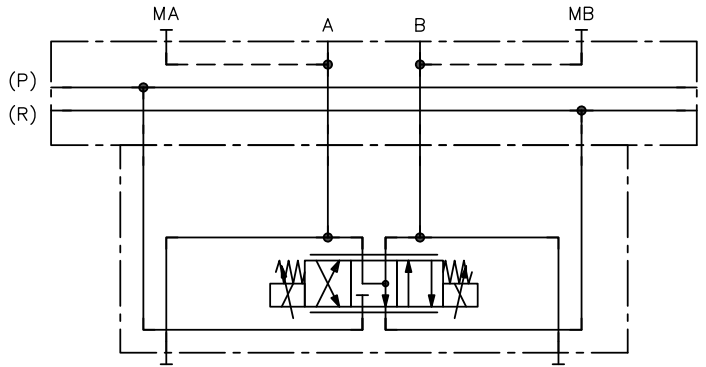

NBVP 16 G/R/A9/400/B9/700-M/3

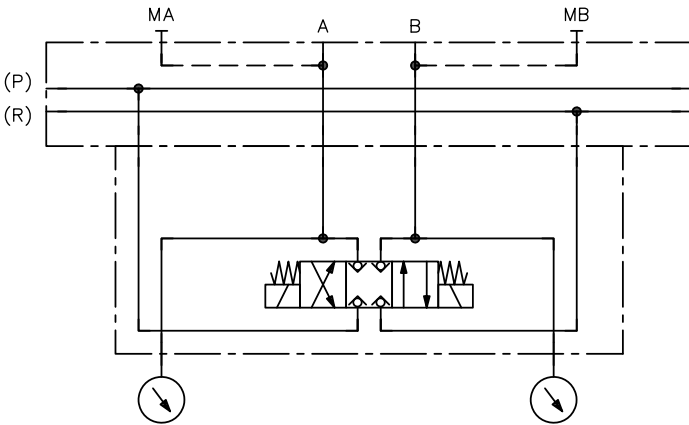

NBVP 16 Z/R/AB1.5/4/S-M/3

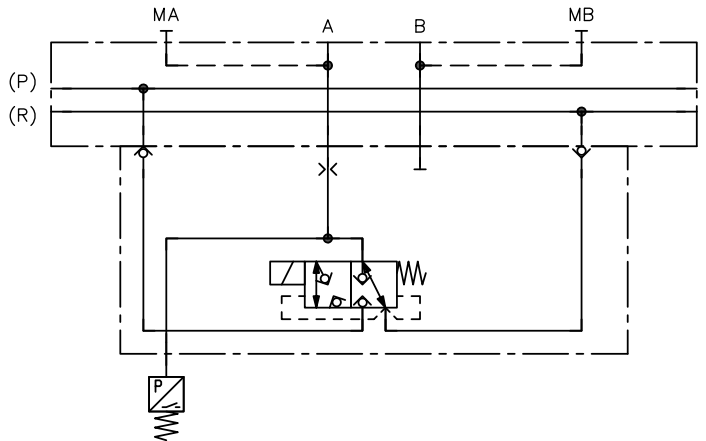

**NBMD 16 Z/EMP 21S/10/3**

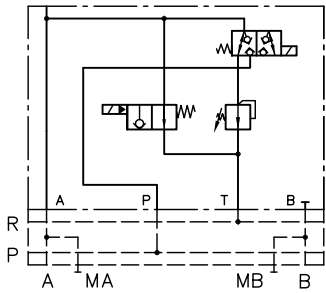

**NSMD 2 K/GRK/M/0**

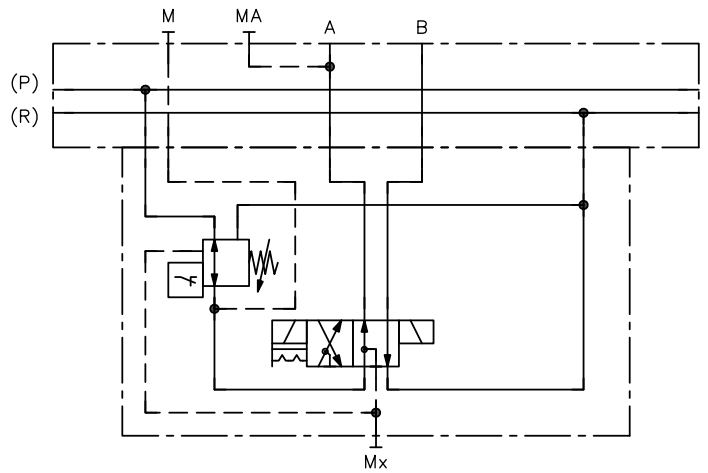

**NPMVP 4-41/G 24/3**

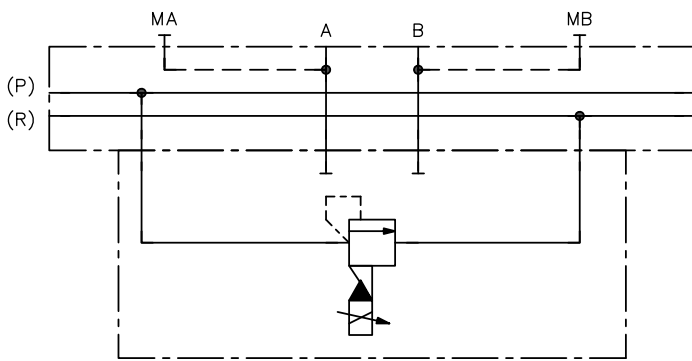

**NBVP 16S/2-M/3**

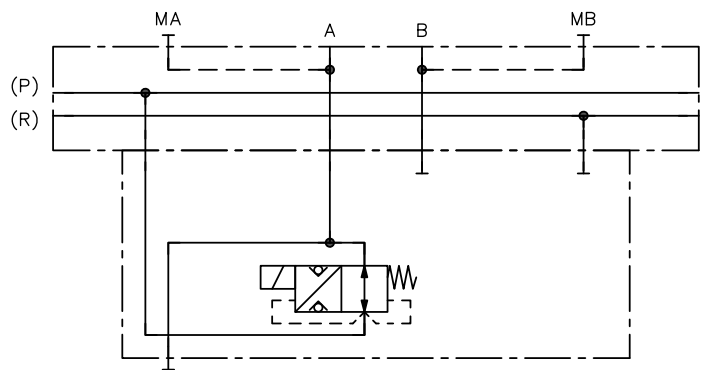

**SP 1 G - A/9**

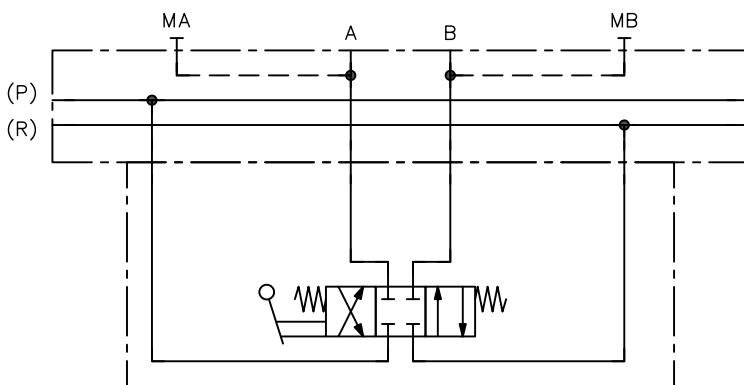

NBVP 16 G/A9/400B9/600/M/10  
NBVP 16 G/A9/400B9/600/M/10

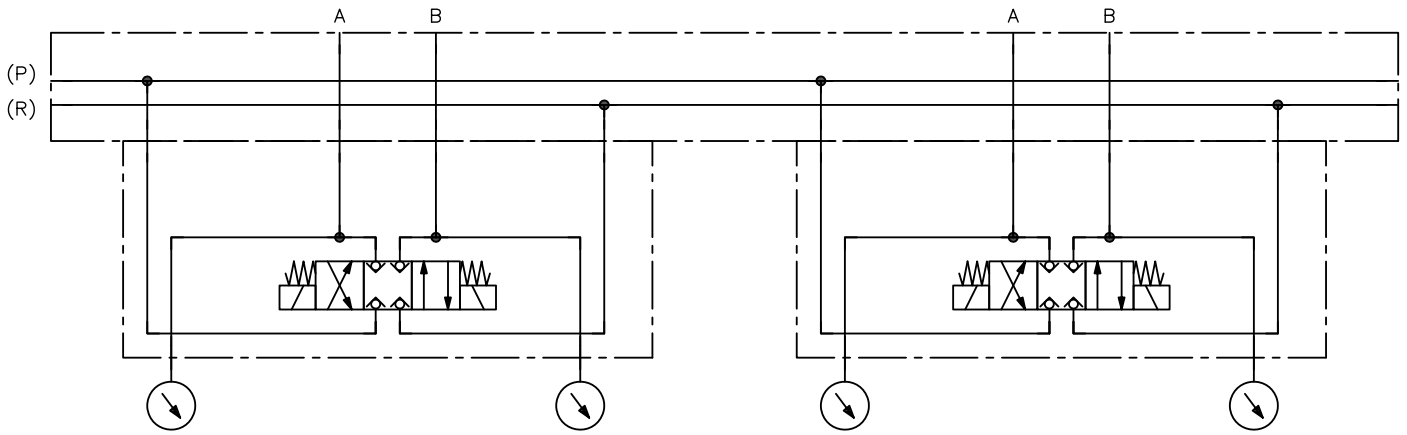

## 2.3.2 Sub-plates

### Ordering examples with additional elements

.../3-MBX 84 G-9/400-...  
 .../0-MDT 11-400-X-...  
 .../3-MAX 84 Z-MBX 84 G-...

Coding	Description	Connection	
		A, B	M, M1, M2, MA, MB
/0	Series (See coding for double sub-plate for two individual sections /10)	G 3/8	G 1/4
/01	Series	G 1/4	G 1/4
/02	Position of the consumer ports on opposite side	G 3/8	G 1/4
/1	additional, releasable check valve in A (Type CRH 1 to <a href="#">D 7712</a> )	G 3/8	--
/2	with additional throttle in T (Type Q 30 to <a href="#">D 7730</a> )	G 3/8	G 1/4
/3	additional pressure gauge connections MA and MB (See coding for double sub-plates for two individual sections /10)	G 3/8	G 1/4
/4	additional drain port for the combination with the intermediate plate NZP 16 SDM 2L to <a href="#">D 7788 Z</a>	G 3/8	G 1/4
	<p><b>i</b> <b>INFORMATION</b>            The following valve sections must also have sub-plate coding /4. For the end plate, coding -1L to <a href="#">Chapter 2.5, "End plates"</a>, must be selected.</p>		
/5	doubly releaseable check valve	G 3/8	--
/6	arbitrary blocking of the P channel in combination with 2/2 directional valves, such as NBVP 16 S/2-M, to relieve the continuing P channel also with 3/2 directional valves, such as NBVP 16 Z/2-M.	--	G 1/4
/8	For mounting of valve sections type BVH 11 to <a href="#">D 7788 BV</a>	G 3/8	G 1/4
/9	For installation of manually operated directional spool valves type SP 1 to <a href="#">D 5650/1</a>	G 3/8	G 1/4
/10	Double sub-plate for mounting two individual sections	G 3/8	--
	<p><b>i</b> <b>INFORMATION</b>            A block is shown in the order coding over 2 lines.</p>		

**Circuit symbols**

Coding /0, /02

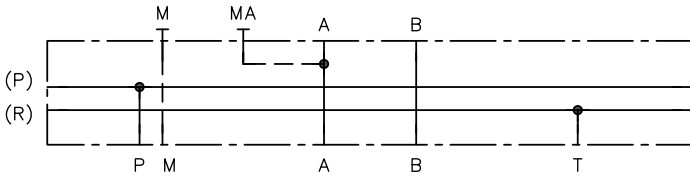

Coding /01

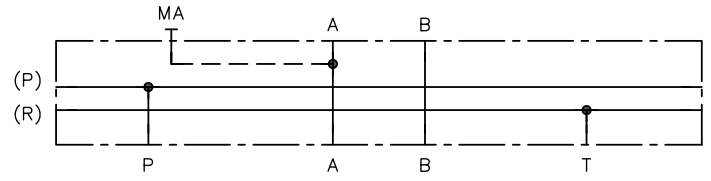

Coding /1

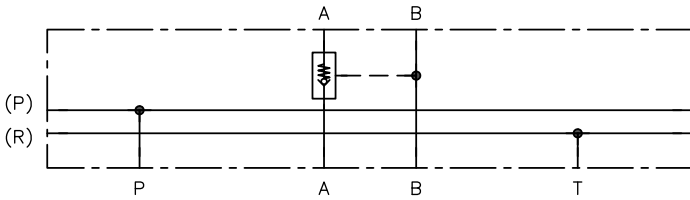

Coding /2

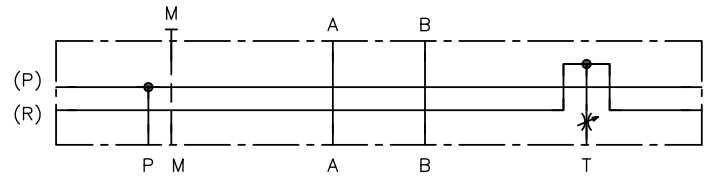

Coding /3, /8, /9

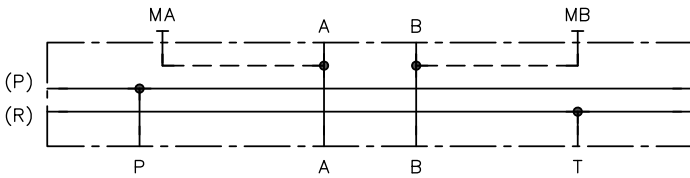

Coding /4

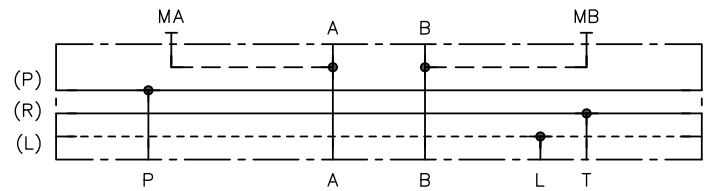

Coding /5

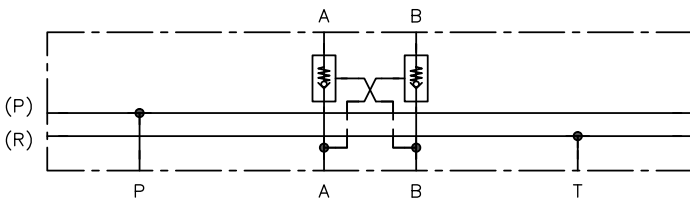

Coding /6

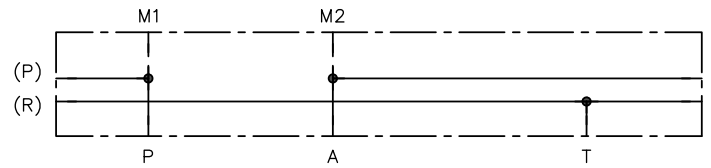

Coding /10

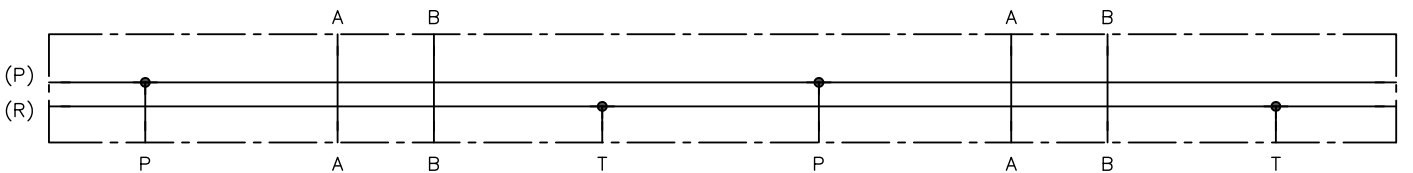

### 2.3.3 Sub-plate additional elements

Coding Port	Description	For sub-plate
M	Additional element at port M	/0, /02, /2
MA	Additional element at port MA	/0, /01, /02, /3, /4, /8, /9
MB	Additional element at port MB	/3, /4, /8, /9
M1	Additional element at port M1	/6
M2	Additional element at port M2	/6

#### **i** INFORMATION

Ports without specification of the terminal assignment are delivered sealed.

#### Possible add-on elements

Coding	Description	Document
X 84 X 84 L X ...	<ul style="list-style-type: none"> <li>Fittings type X 84</li> </ul>	D 7077
9/... 95/...	<ul style="list-style-type: none"> <li>Pressure gauge</li> </ul>	D 7077
DG 3 ...	<ul style="list-style-type: none"> <li>Mechanical pressure switch</li> <li>Manifold mounting</li> </ul>	D 5440
DG 51 ...	<ul style="list-style-type: none"> <li>Electronic pressure switch</li> <li>Digital display</li> <li>Pipe connection</li> </ul>	D 5440 E/2
DG 6 ...	<ul style="list-style-type: none"> <li>Electronic pressure switch</li> <li>Pipe connection</li> </ul>	D 5440 F
DG 7 ...	<ul style="list-style-type: none"> <li>Electronic pressure switch (IO-Link)</li> <li>Pipe connection</li> </ul>	D 5440 G
DG 11 ...	<ul style="list-style-type: none"> <li>Electronic pressure transducer (<math>\leq 1000</math> bar)</li> <li>Pipe connection</li> <li>DIN A</li> </ul>	D 5440 T/2
DT 2 ...	<ul style="list-style-type: none"> <li>Electronic pressure transducer (<math>\leq 600</math> bar)</li> <li>Pipe connection</li> <li>M12x1</li> </ul>	D 5440 T/1
AC ...	<ul style="list-style-type: none"> <li>Miniature hydraulic accumulator</li> </ul>	D 7571

## 2.4 Intermediate plates

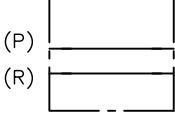
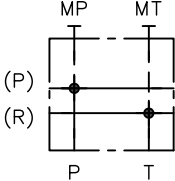
Coding	Description	Flow rate Q <sub>max</sub> (l/min)	Pressure p <sub>max</sub> (bar)	Document
CZ CZA CZD LZ	Pressure reducing valve for pressure reduction in the downstream P channel see Chapter 2.4.1, "Pressure reducing valves in the P channel"	22	400	D 7745 D 7745 L
Z 5	Intermediate plate as spacer (50 mm) without internal function			
Z 52	Intermediate plate with additional P and R ports			
ZPL/V... ZPL/S...	Intermediate plate for a 2nd Speed see Chapter 2.4.2, "Intermediate plate for a 2nd Speed"			D 7490/1
ZPL/MVE 6/.. ZPL/MVE 6/..R ZPL/MVEX 6/.. ZPL/MVEX 6/..R	Intermediate plate with pressure-limiting valve, drain valve and accumulator port <ul style="list-style-type: none"> <li>Coding ZPL/MVEX 6 - component approved pressure-limiting valve (certified valve)</li> <li>Coding ../R - check valve in P</li> </ul>	60	400	D 7000/1 D 7000 TUV
ZPL/P4... ZPL/P 45...	Intermediate plate with proportional pressure-limiting valve for a second pressure circuit in BA valve bank see Chapter 2.4.3, "Intermediate plate with proportional pressure-limiting valve for second pressure circuit in BA valve bank"	16	400	D 7485/1
<b>Shut-off disks or orifices</b>				
XR XP XPR	Shut-off disc for the P channel and/or R channel	--	P: 315 R: 50 *	
XP... XR... XP...R...	Orifices in P channel and/or R channel possible orifice diameters (mm) ∅ 0.5 / 0.6 / 0.8 / 1.0 / 1.5 / 2.0 / 2.5 / 3.0	--	P: 315 R: 50 *	
XP...R	Shut-off disc in the R channel and orifice in the P channel	--	P: 315 R: 50 *	
XPR...	Shut-off disc in the P channel and orifice in the R channel	--	P: 315 R: 50 *	

\* observe the maximum permissible return pressure of installed valves!

**Circuit symbols**

Coding  
ZPL/MVE 6/...  
ZPL/MVEX 6/...

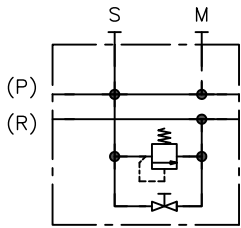

Coding  
ZPL/MVE 6/.../R  
ZPL/MVEX 6/.../R

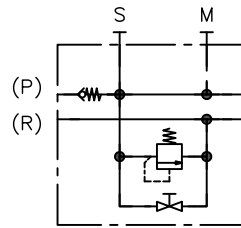

Coding **XP**

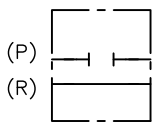

Coding **XR**

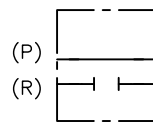

Coding **XPR**

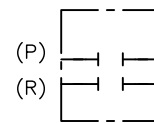

Coding **XP ...**

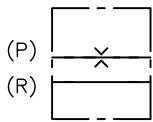

Coding **XR ...**

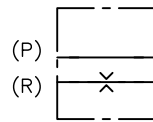

Coding **XP ... R**

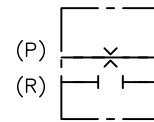

Coding **XPR ...**

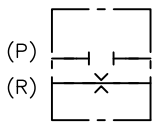

Coding **XP ... R ...**

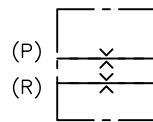

## 2.4.1 Pressure reducing valves in the P channel

### Ordering example

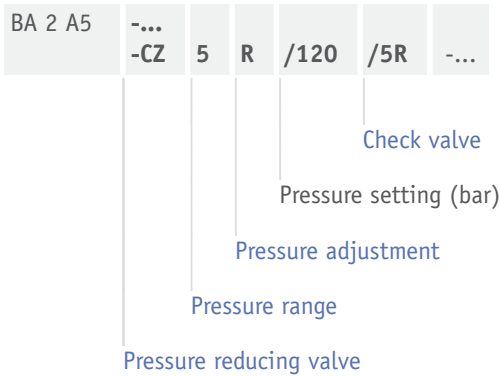

### Pressure reducing valve

Coding	Description	Connection	
		M2, M3, M4, M5, M6	S
-CZ	Pressure reducing valve type CDK to D 7745	G 1/4	--
-CZA	Pressure reducing valve type CDK according to D 7745, valve turned through 90°	G 1/4	--
-CZD	Pressure reducing valve type CDK according to D 7745, with direct accumulator port	G 1/4	G 3/8
-LZ	Pressure reducing valve type CLK to D 7745 L, with overpressure function	G 1/4	--
-CZX		G 1/4	--
-CZAX	<ul style="list-style-type: none"> <li>without pressure reducing valve</li> </ul>	G 1/4	--
-CZDX	<ul style="list-style-type: none"> <li>with tapped plug</li> <li>prepared for retrofitting</li> </ul>	G 1/4	G 3/8
-LZX		G 1/4	--

#### Coding -CZ

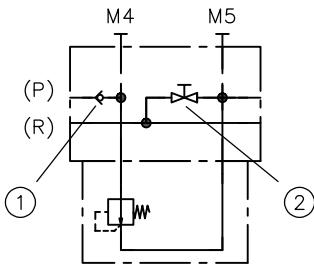

- 1 Check valve in P coding R
- 2 Drain valve

#### Coding -CZA

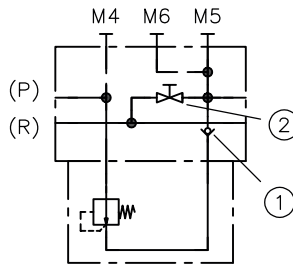

- 1 Check valve in P coding R
- 2 Drain valve

#### Coding -LZ

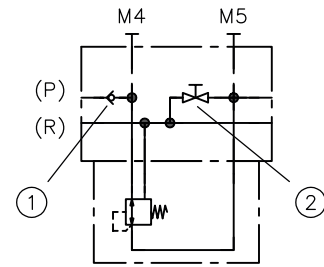

- 1 Check valve in P coding R
- 2 Drain valve

#### Coding -CZD

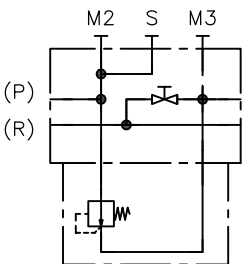

#### Coding -CZX, CZAX, CZDX, LZX

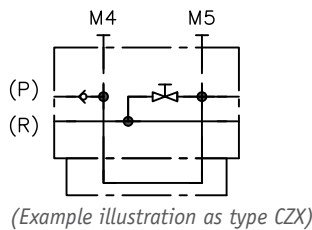



## Pressure range

Coding	Pressure range p <sub>A</sub> (bar)	Flow rate Q <sub>max</sub> (l/min)	Coding	Pressure range p <sub>A</sub> (bar)	Flow rate Q <sub>max</sub> (l/min)
08 *	50 ... 400 (450) **	12	<b>Short model (not for type LZ)</b>		
081 *	50 ... 400 (500) **	12	0.8K	55 ... 310	12
1	30 ... 300	12	1K	30 ... 200	12
11	30 ... 380	12	2K	20 ... 140	12
2	20 ... 200	12	5K	15 ... 90	12
21	20 ... 250	12	21K	18 ... 200	6
5	15 ... 130	12	22K	12 ... 140	6
51	15 ... 165	12	25K	8 ... 90	6
22	12 ... 200	6	208K	30 ... 310	6
25	8 ... 130	6	51K	70 ... 200	22
211	18 ... 380	6	52K	50 ... 140	22
221	12 ... 250	6	55K	30 ... 90	22
251	8 ... 165	6	508K	110 ... 310	22
52	50 ... 200	22			
55	30 ... 130	22			
511	70 ... 380	22			
521	50 ... 250	22			
551	30 ... 165	22			
X	prepared, with tapped plug				

\* not for type LZ

\*\* Value in brackets define the pressure stage

## Pressure adjustment

Coding	Description	Circuit symbol
Without coding	Fixed, tool adjustable	
R	Manually adjustable, with lock nut not directly combinable next to each other	
H	Turn knob, lockable not for type LZ	

## Check valve

Coding	Description
5	without check valve in P
5R	with check valve in P (not for type CZD)

## 2.4.2 Intermediate plate for a 2nd Speed

Application: Optional switching to a second speed, for example for set-up mode or to vary the flow rate to traverse speed profiles.

### Ordering example

BA 2 A5	-... -ZPL/V	/PB 0,3	-... -G 24
---------	----------------	---------	---------------

2.4.3.1 "Solenoid voltage and solenoid male connector for proportional solenoid"  
Orifice in the P channel  
Intermediate plate for a 2nd Speed

### Intermediate plate for a 2nd Speed

2/2 directional seated valves, type EM 21 and EMP 21 to D 7490/1 are used.

Coding	Description
ZPL/V	N/C contact (type EM 21 V)
ZPL/S	N/O contact (type EM 21 S)
ZPL/VPG	N/C contact, damped switching behaviour (type EMP 21 VG)
ZPL/SPG	N/O contact, damped switching behaviour (type EMP 21 VG)
ZPL/VP	N/C contact, proportional valve (throttle function, type EMP 21 V)
ZPL/SP	N/O contact, proportional valve (throttle function, type EMP 21 S)

Coding **ZPL/SP**

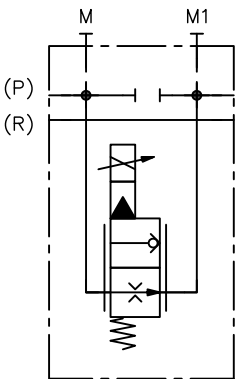

Coding **ZPL/S(PG)/PB...**

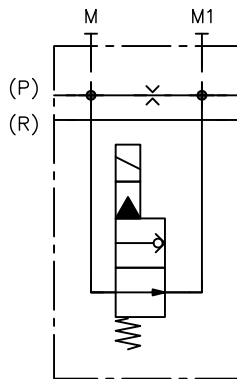

Coding **ZPL/S(PG)/P**

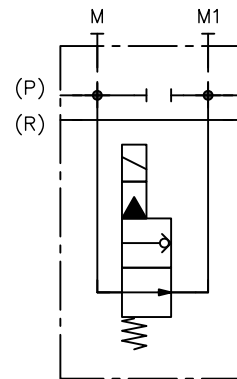

Coding **ZPL/VP**

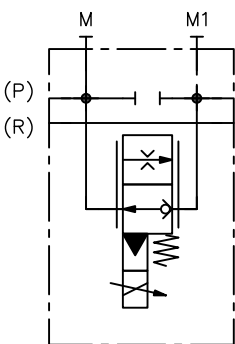

Coding **ZPL/V(PG)/PB...**

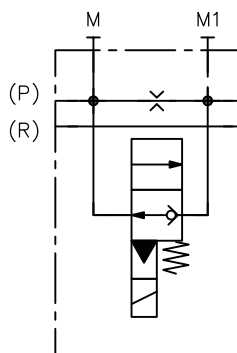

Coding **ZPL/V(PG)/P**

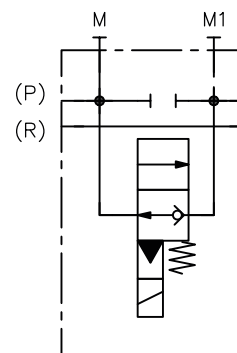

**Orifice in the P channel**

Coding	Orifice diameter $\varnothing$ (mm)
P	closed (not sealed for zero leakage)
PB 0.3	0,3
PB 0.4	0,4
PB 0.5	0,5
PB 0.8	0,8
PB 1.0	1,0
PB 1.5	1,5
PB 1.8	1,8
PB 2.0	2,0
PB 2.5	2,5

**! NOTICE**

Not in combination with coding ZPL/VP and ZPL/SP.

## 2.4.3 Intermediate plate with proportional pressure-limiting valve for second pressure circuit in BA valve bank

Application: Compact solution for two pressure circuits in one valve bank.

**NOTICE**

Combination with a dual-circuit pump, for example type HK 4 to D 7600-4 and a connection block type Sk 6905 Z/AP is feasible.

**Circuit symbol**

Prop. pressure-limiting valve **ZPL / P..**

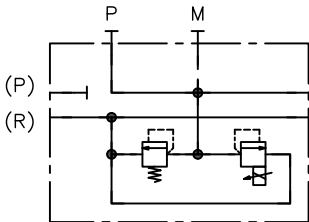

**Example schematic plan**

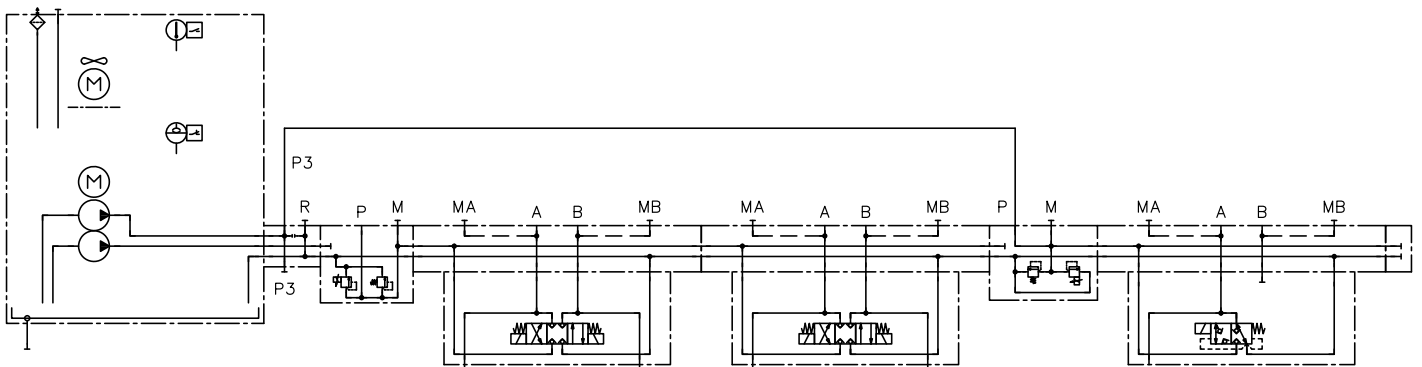

**Ordering example**

HKF 449 DT/1 - HH 2,5/2,5 - ... **-ZPL / P45-42** /G 24 **-150** /R -...

- "Proportional pressure-limiting valve"
- max. pressure setting of pressure-limiting valve (bar) MVF
- 2.4.3.1 "Solenoid voltage and solenoid male connector for proportional solenoid"
- Check valve at P (optional)

## Proportional pressure-limiting valve

Coding of main valve	Proportional actuator			
	-41	-42	-43	-44
Proportional controllable pressure range (bar) $p_{min}$ to $p_{max}$				
ZPL / P4	5 ... 180	5 ... 290	5 ... 400 (440)*	-
ZPL / P45	5 ... 110	5 ... 180	5 ... 270	5 ... 400 (450)*

\* Value in brackets define the pressure stage

### **i** INFORMATION

For details see proportional pressure-limiting valve type PMVP to [D 7485/1](#)

### 2.4.3.1 Solenoid voltage and solenoid male connector for proportional solenoid

Coding	Electrical connection	Nominal voltage	Protection class (IEC 60529)
X(G) 12	Industry standard, 11 mm contact gap <ul style="list-style-type: none"> <li>▪ G: with male connector</li> <li>▪ L: with male connector with LED</li> </ul>	12 V DC	IP 65
X(G) 24		24 V DC	
L 12		12 V DC	
L 24		24 V DC	

### Connection pattern



## 2.5 End plates

Coding	Description	Connection																										
		L, M, MR, R, R1, P.	P, P1, R, R1	S, S1, S2																								
1 11 * 12 *	Series	--	--	--																								
1L	additional drain port, only in combination with sub-plates coding /4, see Chapter 2.3.2, "Sub-plates"	G 1/4	--	--																								
2 21 * 22 *	additional P and R port	--	G 3/8	--																								
4 (DG 1)/(DG 2) 4 (DG 1)/(DG 2) 1 * 4 (DG 1)/(DG 2) 2 *	with drain valve, P and R port and two pressure switches to D 5440 (DG 1), (DG 2) - coding for pressure switch	G 1/4	--	--																								
	<table border="1"> <thead> <tr> <th>Coding</th> <th>Pressure switch</th> <th>Adjustment range (bar)</th> </tr> </thead> <tbody> <tr> <td>2</td> <td>Prepared</td> <td>--</td> </tr> <tr> <td>3</td> <td>DG 33</td> <td>200 ... 400 (700) **</td> </tr> <tr> <td>4</td> <td>DG 34</td> <td>100 ... 400</td> </tr> <tr> <td>5</td> <td>DG 35</td> <td>40 ... 250</td> </tr> <tr> <td>6</td> <td>DG 36</td> <td>4 ... 12</td> </tr> <tr> <td>7</td> <td>DG 365</td> <td>12 ... 170</td> </tr> <tr> <td>8</td> <td>DG 364</td> <td>4 ... 50</td> </tr> </tbody> </table>				Coding	Pressure switch	Adjustment range (bar)	2	Prepared	--	3	DG 33	200 ... 400 (700) **	4	DG 34	100 ... 400	5	DG 35	40 ... 250	6	DG 36	4 ... 12	7	DG 365	12 ... 170	8	DG 364	4 ... 50
Coding	Pressure switch				Adjustment range (bar)																							
2	Prepared				--																							
3	DG 33				200 ... 400 (700) **																							
4	DG 34				100 ... 400																							
5	DG 35				40 ... 250																							
6	DG 36				4 ... 12																							
7	DG 365	12 ... 170																										
8	DG 364	4 ... 50																										
6 61 * 62 *	With drain valve	--	--	--																								
<b>End plates with accumulator port (hydraulic accumulator see D 7969)</b>																												
8	additional port S with warning and drain valve	--	--	G 1/2																								
8W	with warning, without drain valve	G 1/4	--	G 1/2																								
80	without warning, without drain valve	G 1/4	--	G 1/2																								
80(8W)/EM 21D(DS) 80(8W)/EM 21S(V) 80(8W)/EMP 21S(V)	like coding 80 or 8W, additionally with electrically actuated drain valve or idle circulation valve	--	--	G 1/2																								
81	multiple P ports	G 1/4	--	--																								
88 88W 880 880(88W)/EM 21D(DS)	see coding 8., however, with two ports S1 and S2	G 1/4	--	G 1/2																								
<b>Transition plates to additional valve banks</b>																												
BWN 1F BWH 1F	Valve bank type BWN 1 and BWH 1 to D 7470 B/1																											
BVH 11	Valve bank type BVH 11 to D 7788 BV Direct mounting to sub-plate coding 8, see Chapter 2.3.2, "Sub-plates"																											

\* Coding .1 with space for one valve section to be mounted later

\*\* Values in brackets define the pressure stage

**Circuit symbols (end plates)**

Coding 1

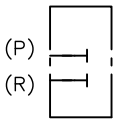

Coding 1L

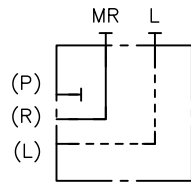

Coding 2

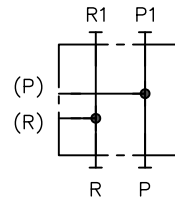

Coding 4  
(example: -46/2)

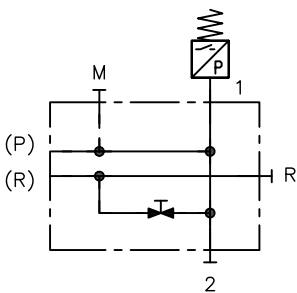

Coding 4  
(example: -47/8)

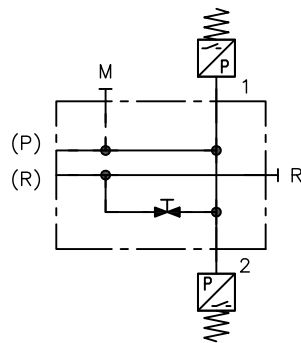

Coding 6

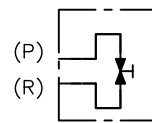

Coding 8

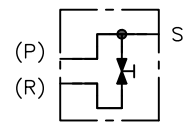

Coding 80, 8W

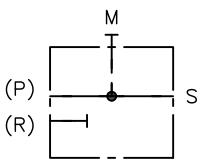

Coding 81

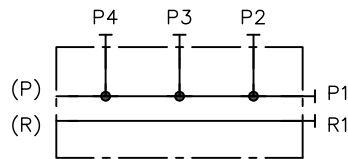

Coding 88

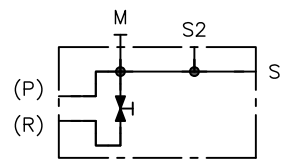

Coding 880, 88W

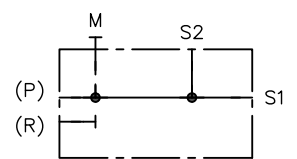

Coding 80 (8W)/EM 21 D

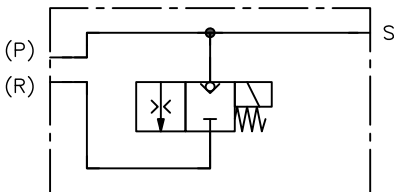

Coding 80 (8W)/EM 21 DS

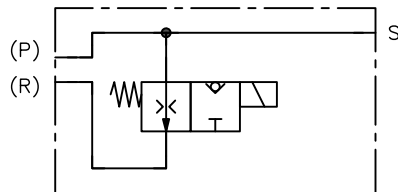

Coding 80 (8W)/EM(P) 21 V

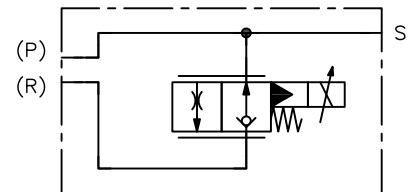

here EMP 21 S shown

Coding 80 (8W)/EM(P) 21 S

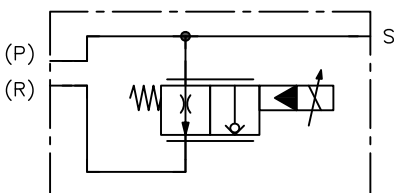

here EMP 21 S shown

Coding 880 (88W)/EM 21 D

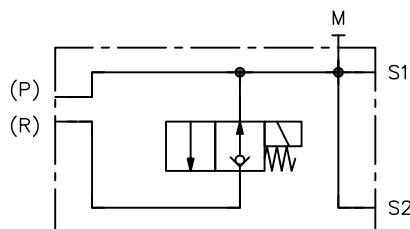

Coding 880 (88W)/EM 21 DS

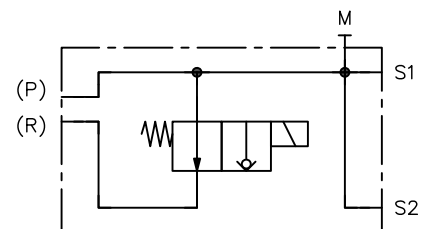

**Circuit symbols (transition plates)**

**BWN(H) 1F**  
**BWH 2F**

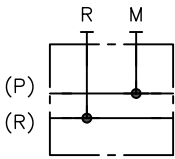

**BWN(H) 1 F1**

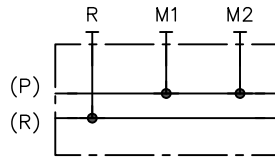

**2.6 Solenoid voltage and connector**

Coding	Electrical connection	Nominal voltage	Protection class (IEC 60529)
X 12	EN 175 301-803 A	12 V DC	IP 65
X 24	▪ <b>X</b> : without male connector	24 V DC	
X 98	▪ <b>L</b> : with male connector with LED	98 V DC	
X 205	▪ <b>WG</b> : with male connector with alternating rectifier	205 V DC	
WG 110	▪ <b>L5K</b> : with 5 m cable connected	110 V AC 50/60 Hz	
WG 230	▪ <b>L10K</b> : with 10 m cable connected	230 V AC 50/60 Hz	

**i INFORMATION**

- The availability of additional solenoid voltages and solenoid male connectors is based on the directional valves used.
- The solenoid voltages and solenoid male connectors are specified at the end of the order coding and are applicable to all the solenoids on the valve bank.
- The specifications regarding the IP protection class apply for versions featuring a properly assembled male connector.
- Assembled pressure switches DG 3, DT 11, DG 1 are supplied as standard with a DIN connector; pressure switches DG 51, DG 6, DG 7 and DT 2 are supplied as standard with an M 12 connection.

**Connection pattern**

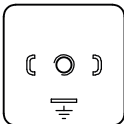

## 3 Parameters

### 3.1 General data

Designation	Valve bank
Design	Segmental construction; up to 10 valve sections
Model	Manifold mounting
Material	Steel, zinc-nickel coated
Attachment	see Chapter 4, "Dimensions"
Installation position	Any
Ports/connections	<ul style="list-style-type: none"> <li>▪ P. = Pump</li> <li>▪ R. = Reflux</li> <li>▪ A, B = Consumers</li> <li>▪ S. = Accumulator</li> <li>▪ M. = Pressure gauge</li> </ul>
Hydraulic fluid	Hydraulic fluid, according to DIN 51524 Parts 1 to 3; ISO VG 10 to 68 according to DIN ISO 3448 Viscosity range: 4 - 400 mm <sup>2</sup> /s Also suitable for biologically degradable hydraulic fluids type HEPG (polyalkylene glycol) and HEES (synthetic ester) at operating temperatures up to approx. +70°C.
Cleanliness level	<b>ISO 4406</b> <u>20/17/14...18/15/12</u>
Temperatures	Environment: approx. -40 to +80 °C, hydraulic fluid: -25 to +80 °C, pay attention to the viscosity range. Start temperature: down to -40 °C is permissible (take account of the start viscosities!), as long as the steady-state temperature is at least 20 K higher during subsequent operation. Biologically degradable hydraulic fluids: note manufacturer specifications. With consideration for the seal compatibility, not above +70°C.

### 3.2 Pressure and volumetric flow

Operating pressure	Connection P: $p_{\max} = 400$ bar Connection R: $p_{\max} = 50$ bar Connection A, B: $p_{\max}$ according to the circuit symbol and actuation
Flow rate	$Q_{\max} = 30$ l/min

#### NOTICE

Observe the specifications of the attached directional valves and upstream hydraulic power packs.

### 3.3 Weight

Connection block	Coding	
	A5 (A8)	= 0.8 kg
	A9	= 0.3 kg
<b>End plates</b>	1, 1L	= 0.3 kg
	2	= 0.8 kg
	4	= 1.2 kg
	6	= 0.4 kg
	8, 80, 8W	= 3.5 kg
	80(8W) / EM 21 D(DS)	= 1.3 kg
	81	= 0.8 kg
	88, 880, 88W	= 3.5 kg
	880(88W) / EM 21 D(DS)	= 3.8 kg
<b>Sub-plates</b>	/01, /02	= 0.6 kg
	/0, /1, /2, /3, /4, /6, /8, /9	= 0.8 kg
	/5	= 1.4 kg
	/10	= 2.7 kg
<b>Intermediate plates</b>	Z 5	= 0.8 kg
	Z 52	= 0.9 kg
	ZPL/MVE(X) 6	= 2.3 kg
	ZPL/V, ZPL/S	= 1.1 kg
	ZPL/P4, ZPL/P45	= 2.0 kg
	CZ, CZA, CZD, LZ	= 2.3 kg
	CZX, CZAX, CLX	= 1.6 kg
<b>Reactive plate</b>	NG 6X	= 0.3 kg
	NG 6X PA, NG 6X PB, NG 6X AT	= 0.4 kg
	NG 6X PA 22	= 1.0 kg
<b>Directional valves</b>	according to type, see corresponding publications	

## 4 Dimensions

All dimensions in mm, subject to change.

### 4.1 Connection block

#### BA 2 A5, BA 2 A8

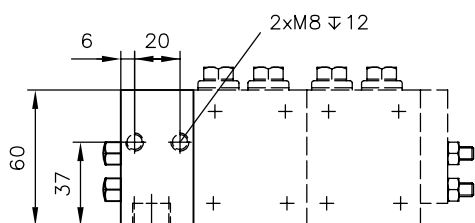
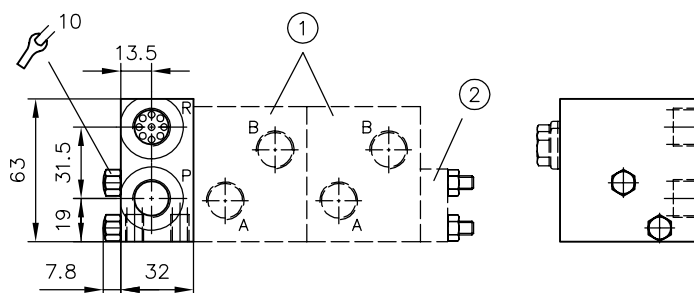

- 1 Valve sections (Chapter 4.2, "Valve sections")
- 2 End plates

#### Ports (ISO 228-1)

P, R

G 3/8

#### BA 2 A9

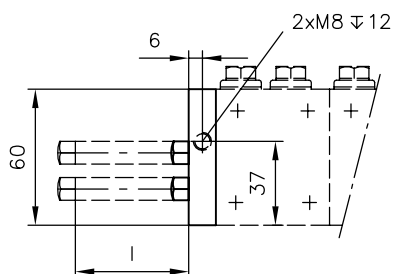
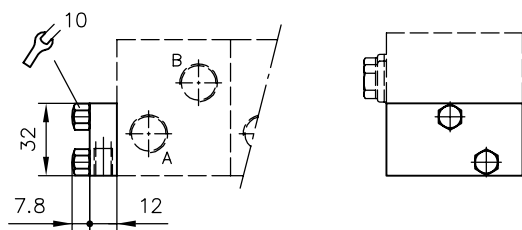

l = 50 Coding .1 with space for one valve section to be mounted later

l = 100 Coding .2 with space for two valve sections to be mounted later

## 4.2 Valve sections

### 4.2.1 Sub-plates

Coding /0

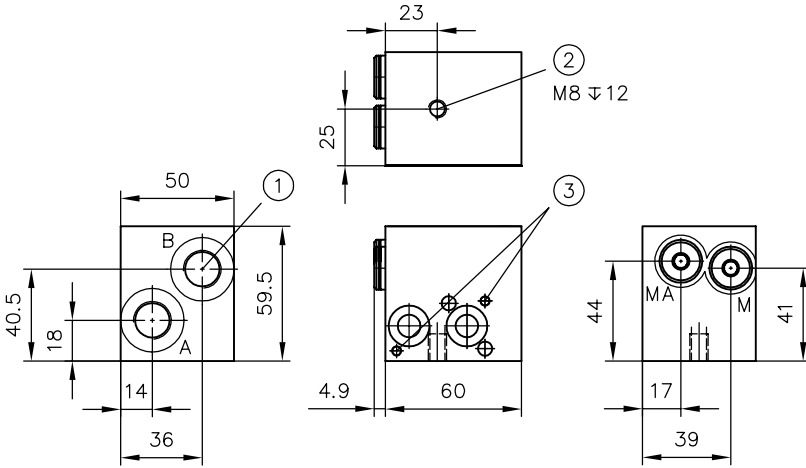

- 1 with 3/2 directional valves connection B sealed
- 2 Metric attachment thread
- 3 Centring pins ISO 8750-4x8-St

Coding /01

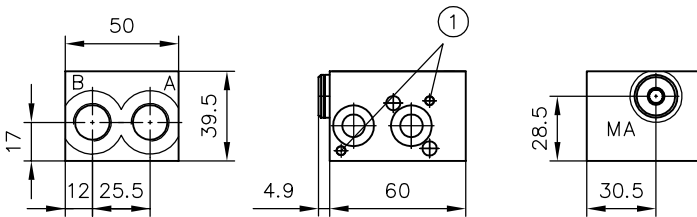

- 1 Centring pins ISO 8750-4x8-St

Coding /02

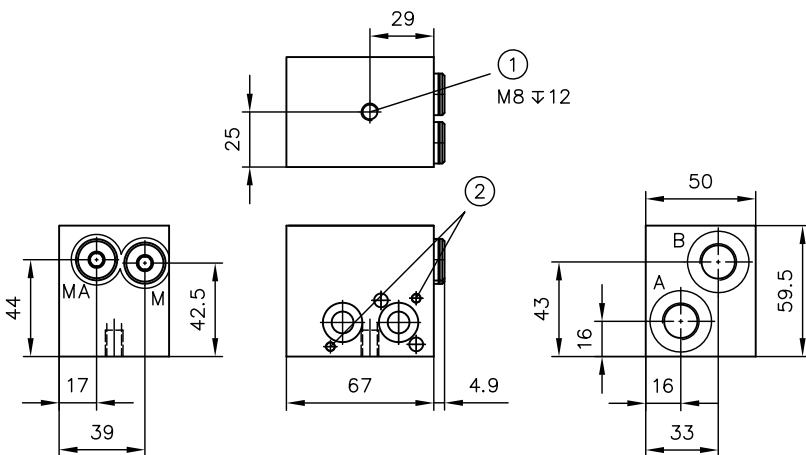

- 1 Metric attachment thread
- 2 Centring pins ISO 8750-4x8-St

Coding

Ports (ISO 228-1)

Coding	Ports (ISO 228-1)	
	A, B	M, MA
/0	G 3/8	G 1/4
/01	G 1/4	G 1/4
/02	G 3/8	G 1/4

Coding /1

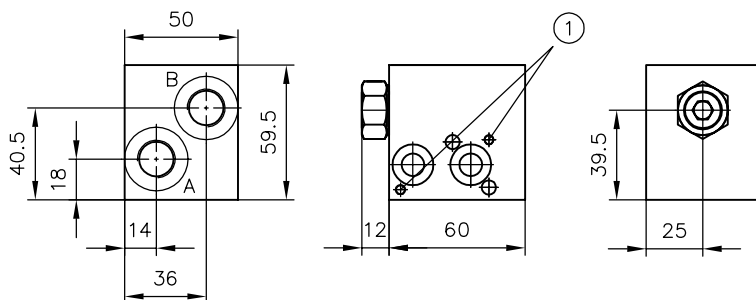

1 Centring pins ISO 8750-4x8-St

Coding /2

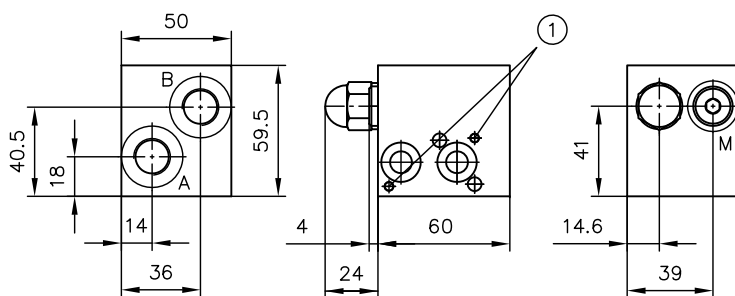

1 Centring pins ISO 8750-4x8-St

Coding /3

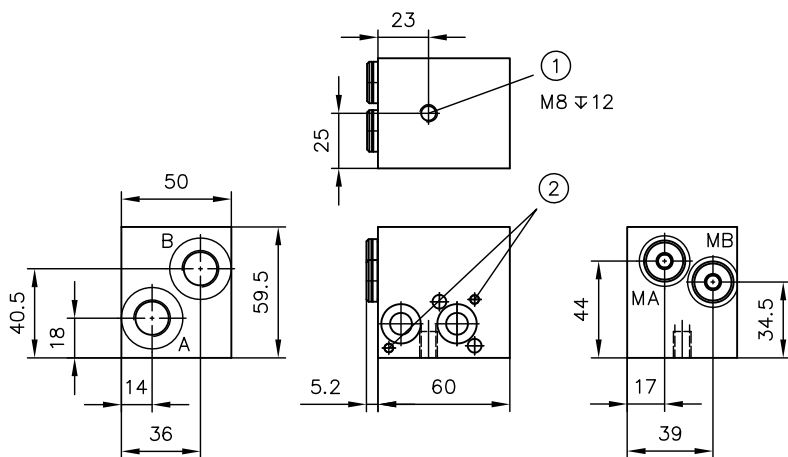

1 Metric attachment thread  
2 Centring pins ISO 8750-4x8-St

Coding /4

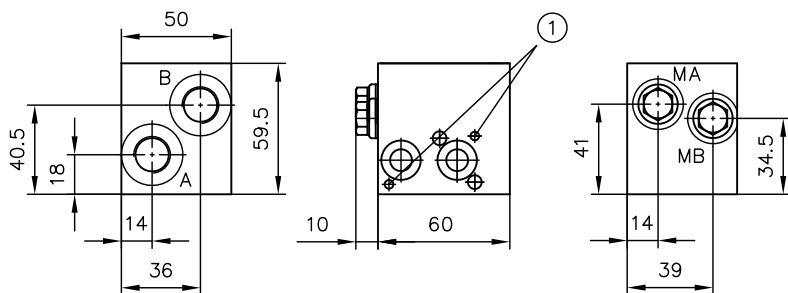

1 Centring pins ISO 8750-4x8-St

Ports (ISO 228-1)	
A, B	G 3/8
M, MA, MB	G 1/4

Coding /5

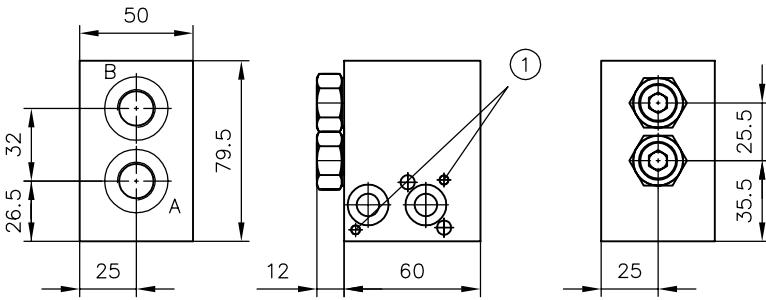

1 Centring pins ISO 8750-4x8-St

Coding /6

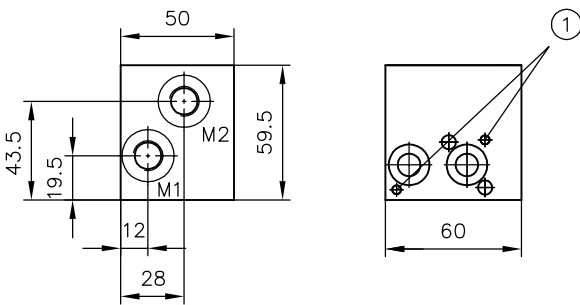

1 Centring pins ISO 8750-4x8-St

Coding /8

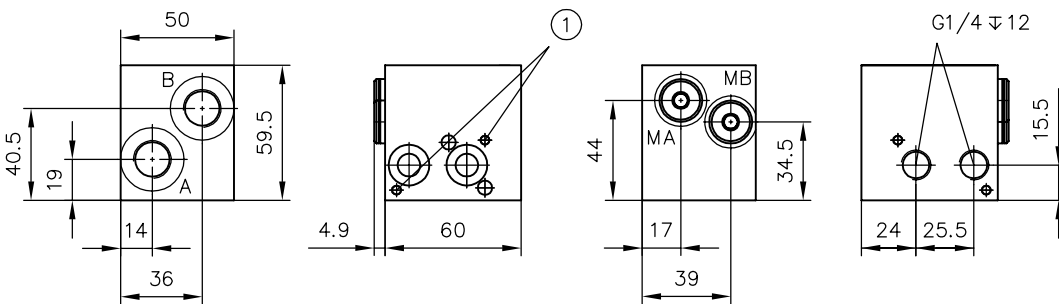

1 Centring pins ISO 8750-4x8-St

Coding /9

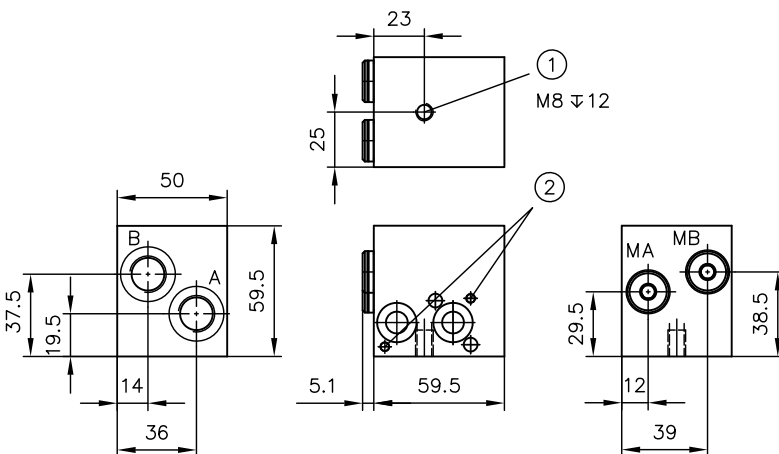

1 Metric attachment thread

2 Centring pins ISO 8750-4x8-St



## 4.2.2 Reactive plates

Coding **NG 6X, NG 6X PA, NG 6X PB, NG 6X AT**

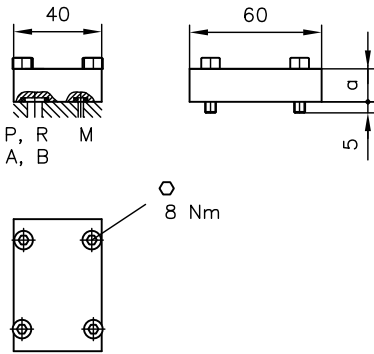

Coding	a
NG 6X	15
NG 6X PA NG 6X PB NG 6X AT	20

	O-ring
A, B, P, R	9.25x1.78 NBR 90 Sh
M	2.90x1.78 NBR 90 Sh

Coding **NG 6 X PA 22**

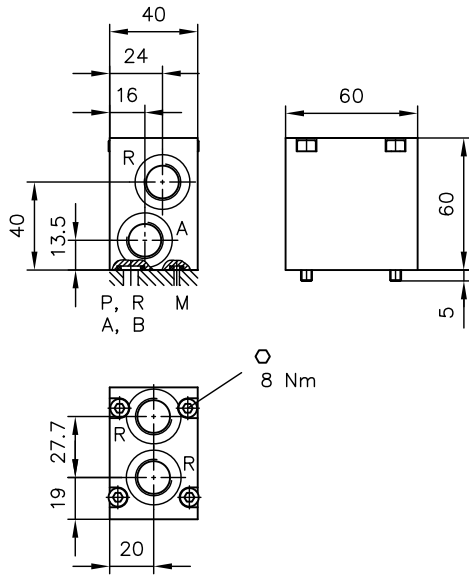

	Ports (ISO 228-1)
A, R	G 3/8

### 4.2.3 Intermediate plates

#### Coding Z 5

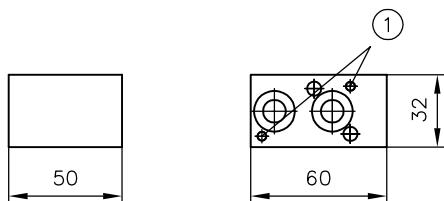

1 Centring pins ISO 8750-4x8-St

#### Coding Z 52

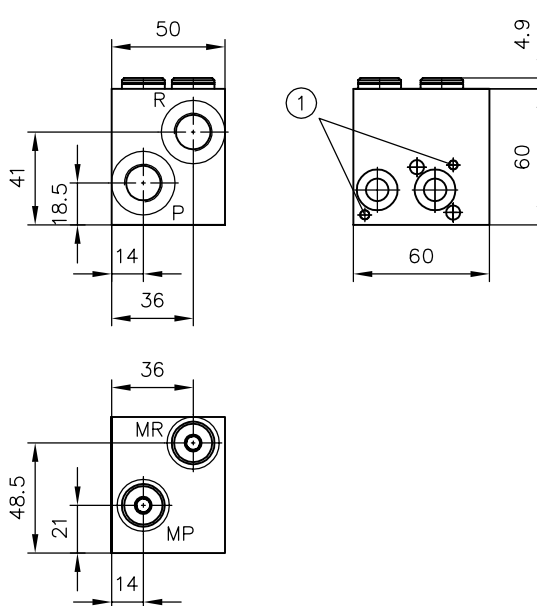

1 Centring pins ISO 8750-4x8-St

#### Ports (ISO 228-1)

P, R	G 3/8
MP, MR	G 1/4

## 4.2.4 Pressure reducing valves

Coding **CZ**

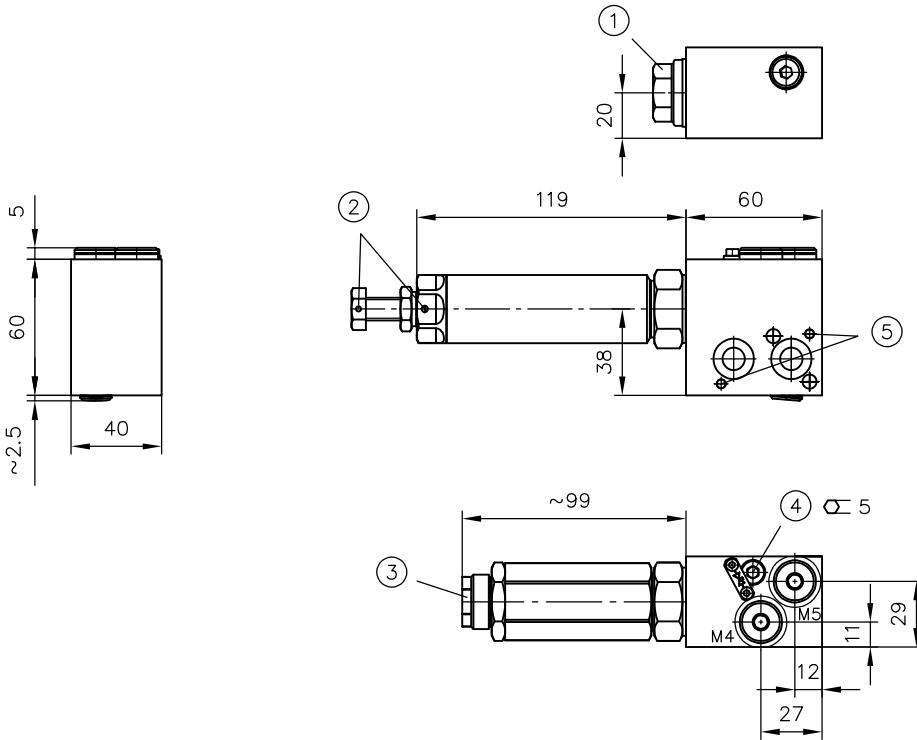

- 1 Tapped plug for type CZX
- 2 Sealing option
- 3 Short model
- 4 Drain valve
- 5 Centring pins ISO 8750-4x8-St

### Ports (ISO 228-1)

M4, M5

G 1/4

Coding **CZA**

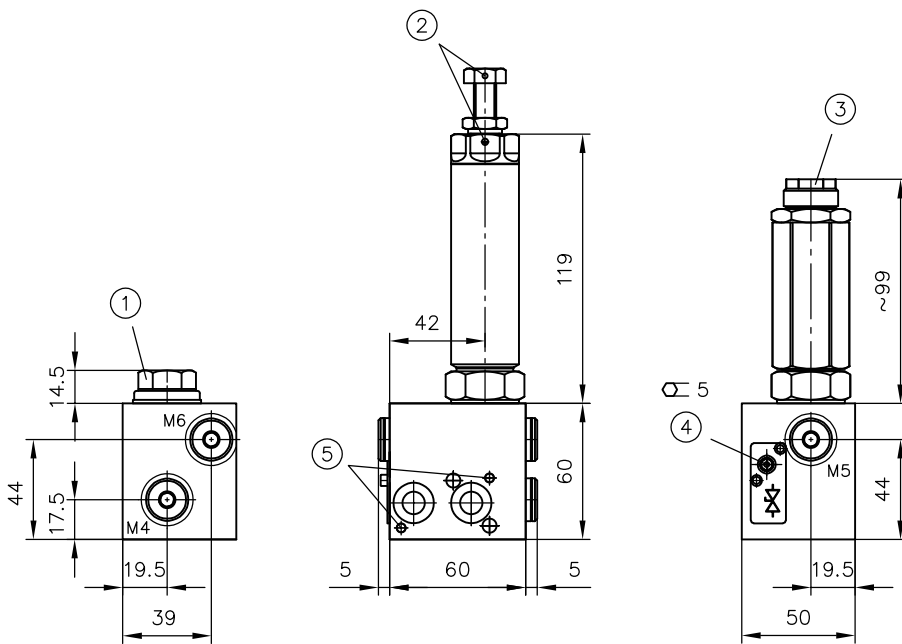

- 1 Tapped plug for type CZAX
- 2 Sealing option
- 3 Short model
- 4 Drain valve
- 5 Centring pins ISO 8750-4x8-St

**Ports (ISO 228-1)**

M4, M5, M6

G 1/4

Coding **CZD**

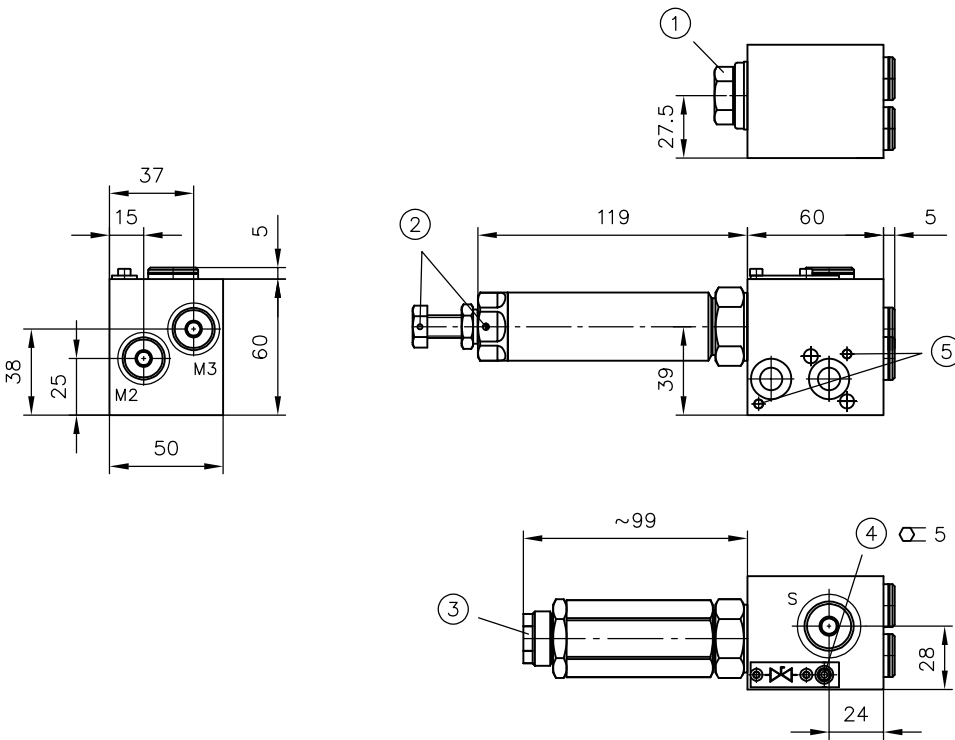

- 1 Tapped plug for type CZX
- 2 Sealing option
- 3 Short model
- 4 Drain valve
- 5 Centring pins ISO 8750-4x8-St

Ports (ISO 228-1)	
M2, M3	G 1/4
S	G 3/8

Coding LZ

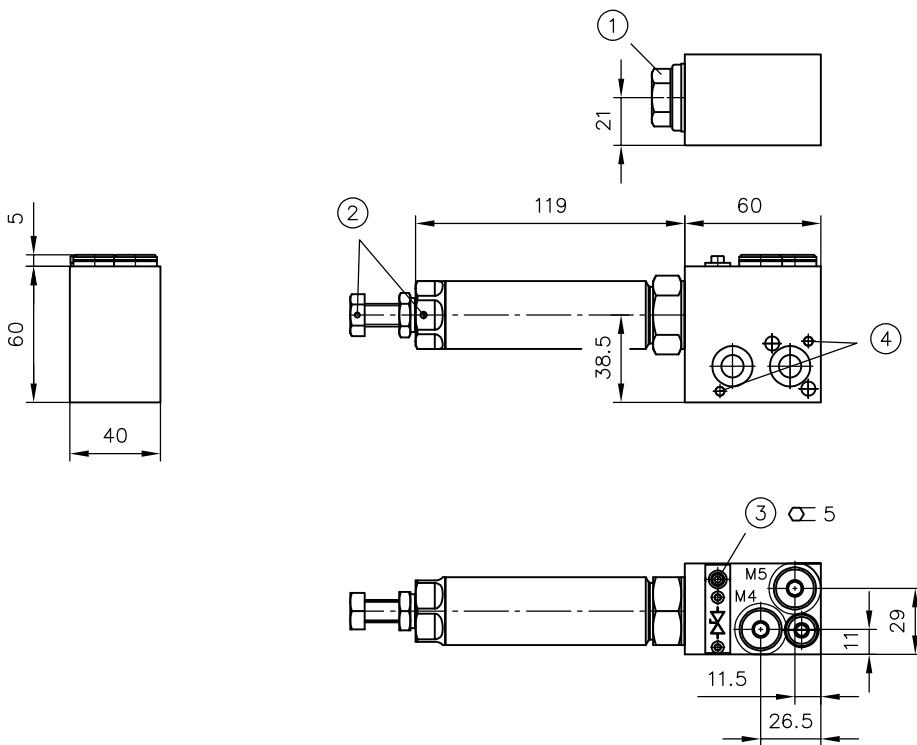

- 1 Tapped plug for type CZX
- 2 Sealing option
- 3 Drain valve
- 4 Centring pins ISO 8750-4x8-St

**Ports (ISO 228-1)**

M4, M5      G 1/4

**Adjustment**

Without coding

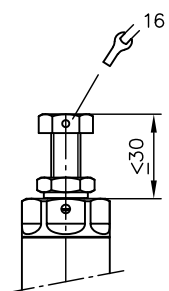

Coding R

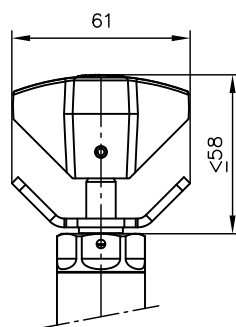

Coding H

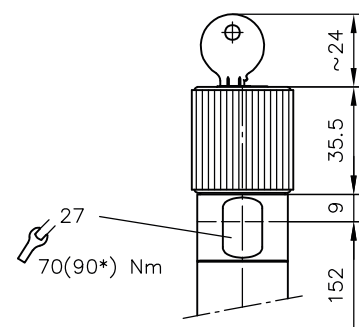

\* CDK3.-08.

## 4.2.5 Intermediate plates for a 2nd Speed

Coding ZPL/V..., ZPL/S...

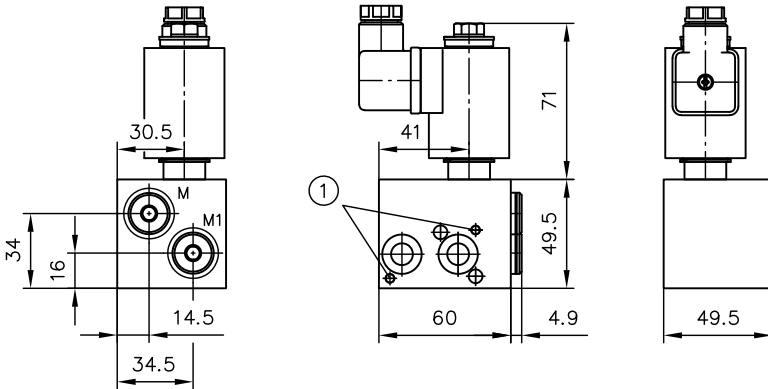

1 Centring pins ISO 8750-4-8-St

### Ports (ISO 228-1)

M, M1	G 1/4
-------	-------

## 4.2.6 Pressure-limiting valves

Coding ZPL/MVE 6, ZPL/MVEX 6

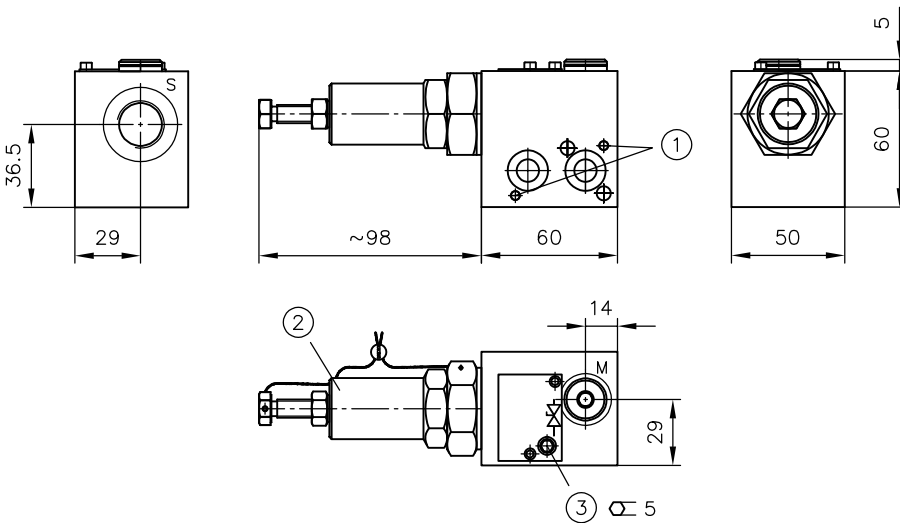

1 Centring pins ISO 8750-4x8-St

2 sealed for type MVEX

3 Drain valve

### Ports (ISO 228-1)

M	G 1/4
S	G 1/2

## 4.2.7 Proportional pressure-limiting valves

Coding ZPL/P4..., ZPL/P45...

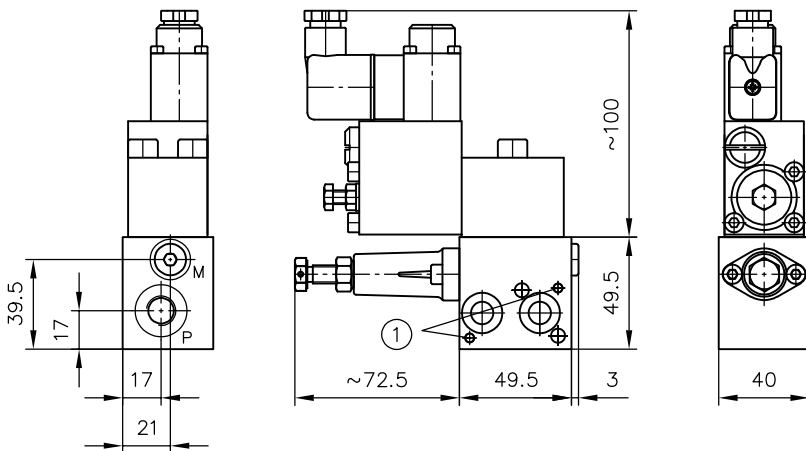

1 Centring pins ISO 8750-4x8-St

### Ports (ISO 228-1)

M	G 1/8
P	G 1/4

## 4.3 End plates

Coding 1

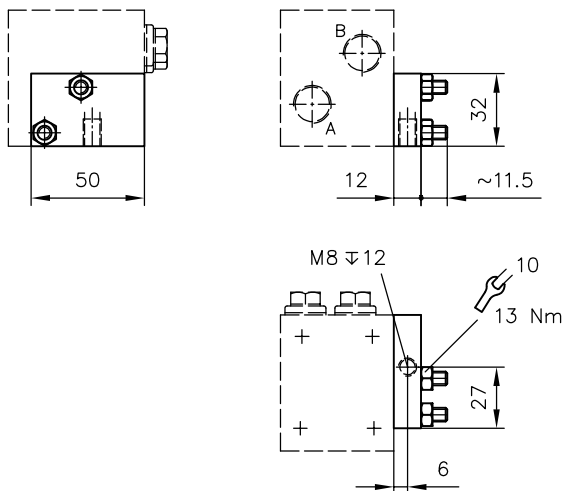

Coding 1L

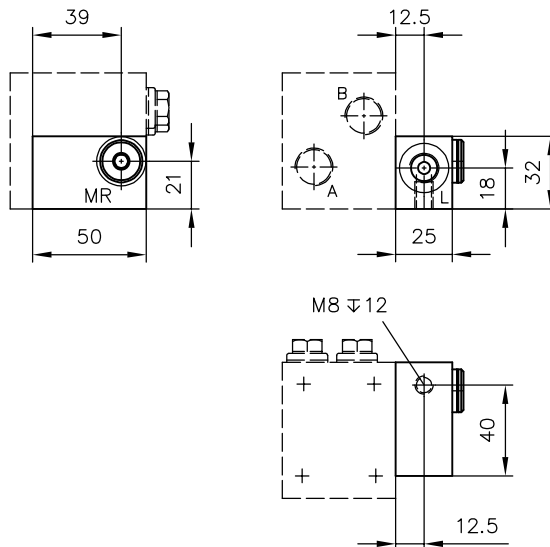

Coding 2

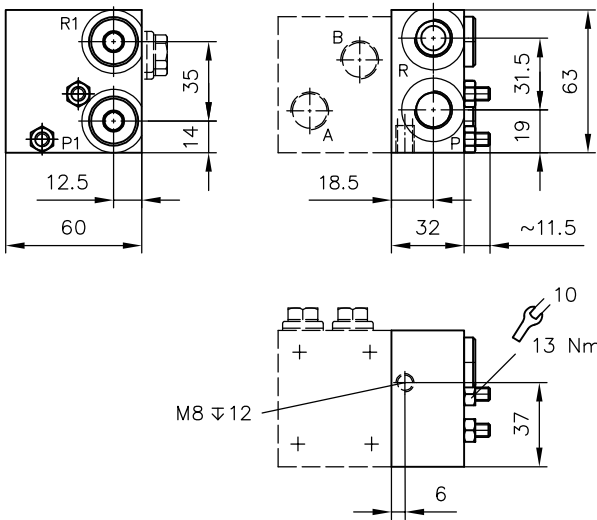

Coding 4

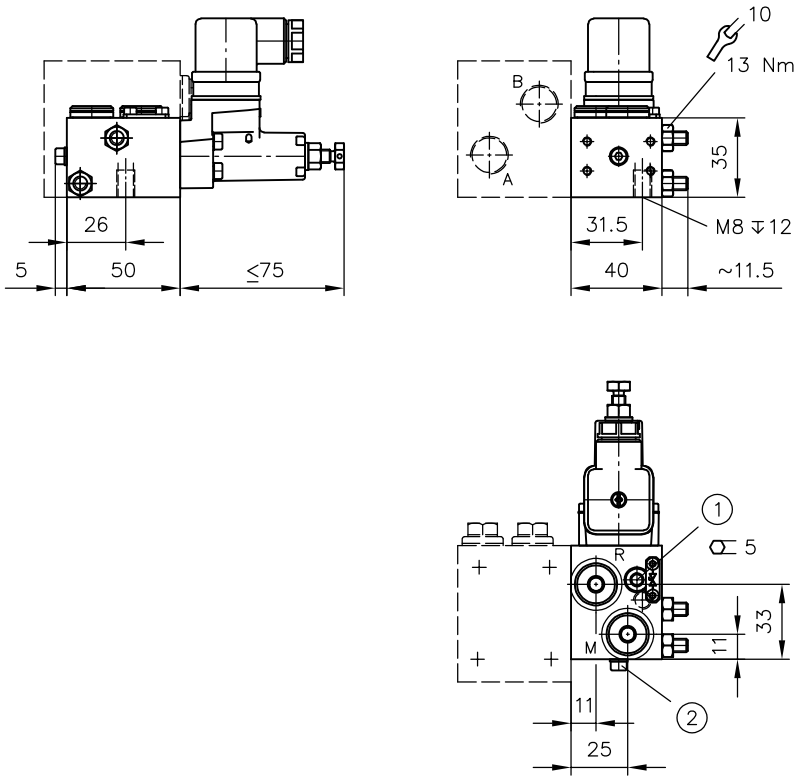

- 1 Drain valve
- 2 Coding 2 (prepared)

Coding	Ports (ISO 228-1)						
	L	M	MR	P	P1	R	R1
1L	G 1/4	--	G 1/4	--	--	--	--
2	--	--	--	G 3/8	G 3/8	G 3/8	G 3/8
4	--	G 1/4	--	--	--	G 1/4	--

Coding 6

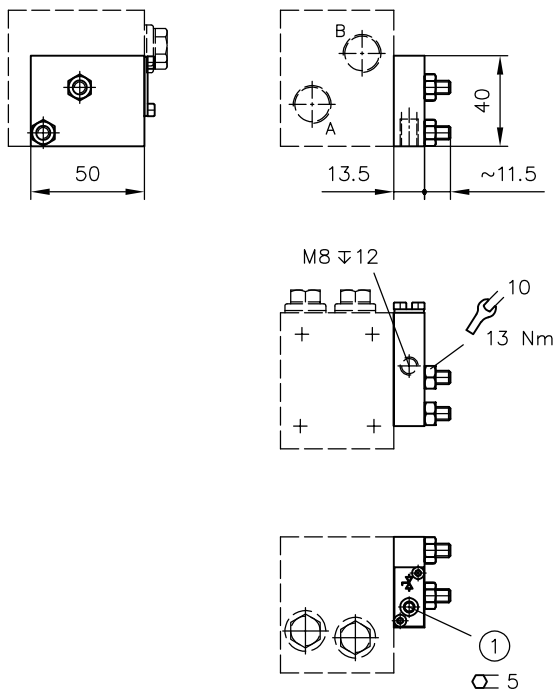

1 Drain valve

Coding 8

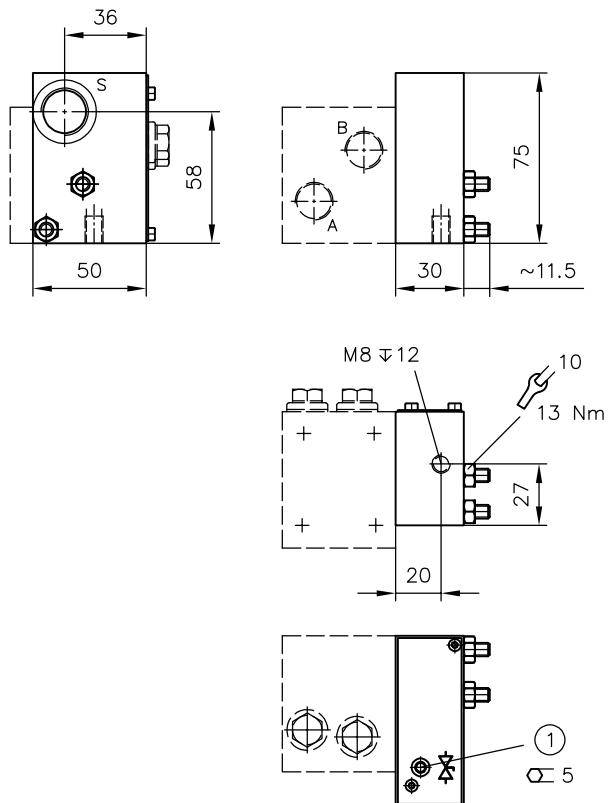

1 Drain valve

Coding 80, 8W

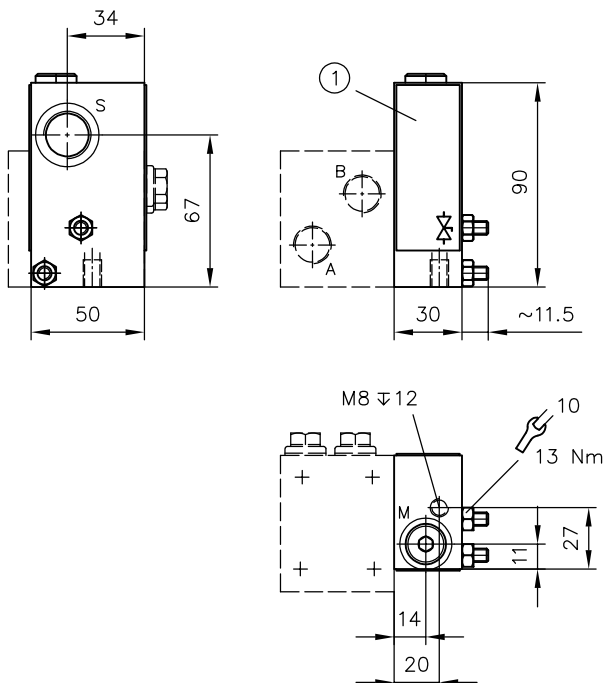

1 Adhesive label only coding 8W

**Ports (ISO 228-1)**

M	G 1/4
S	G 1/2

Coding **80(8W)/EM 21V(S)**, **80(8W)/EM 21D(DS)**, **80(8W)/EMP 21V(S)**

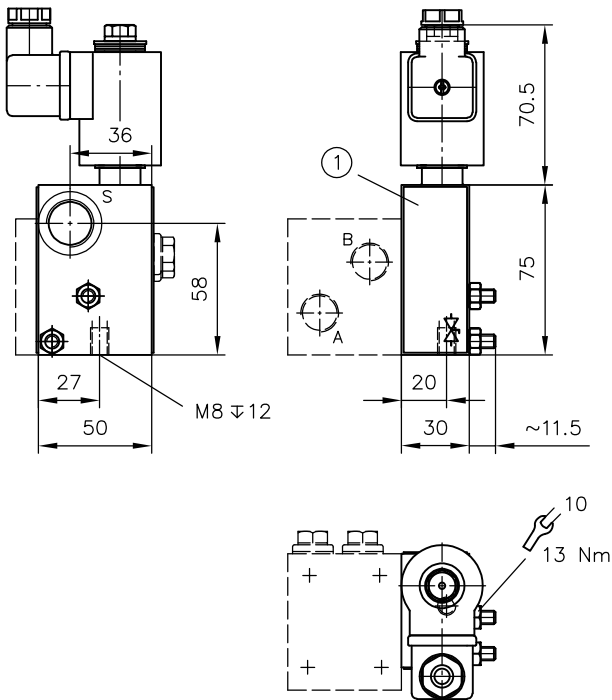

1 Adhesive label only coding 8W/EM(P) 21...

Coding **81**

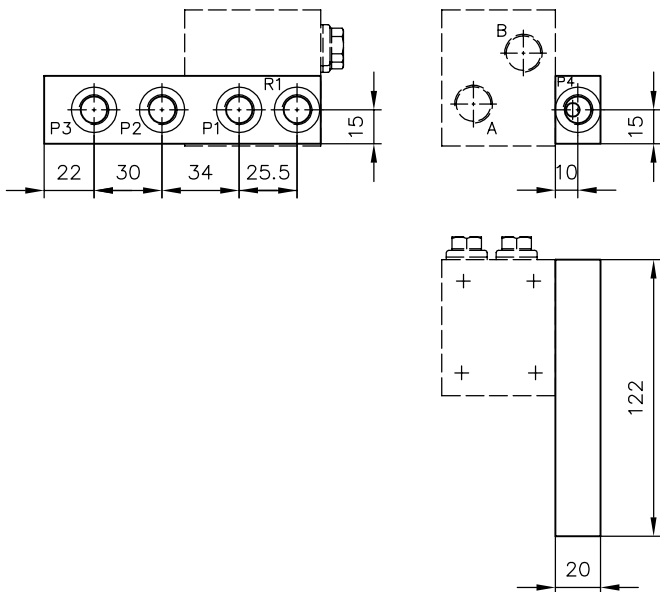

**Ports (ISO 228-1)**

P1, P2, P3, P4, R1	G 1/4
S	G 1/2

Coding **88**

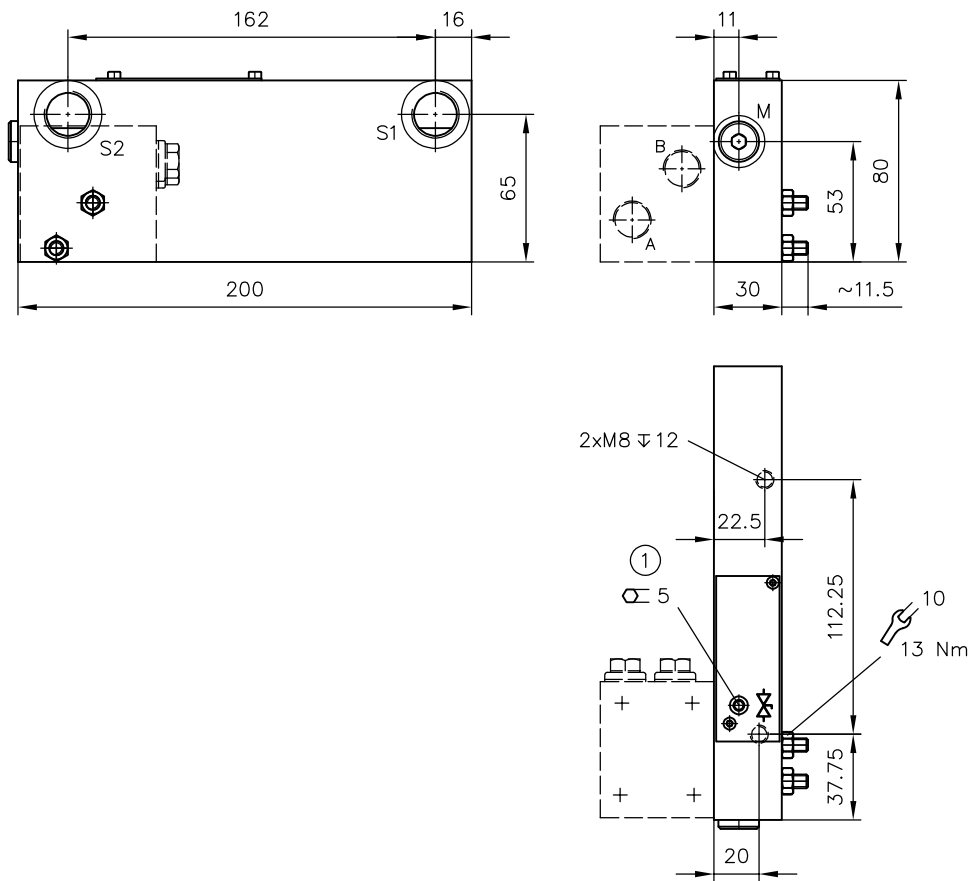

1 Drain valve

Coding 880, 88W

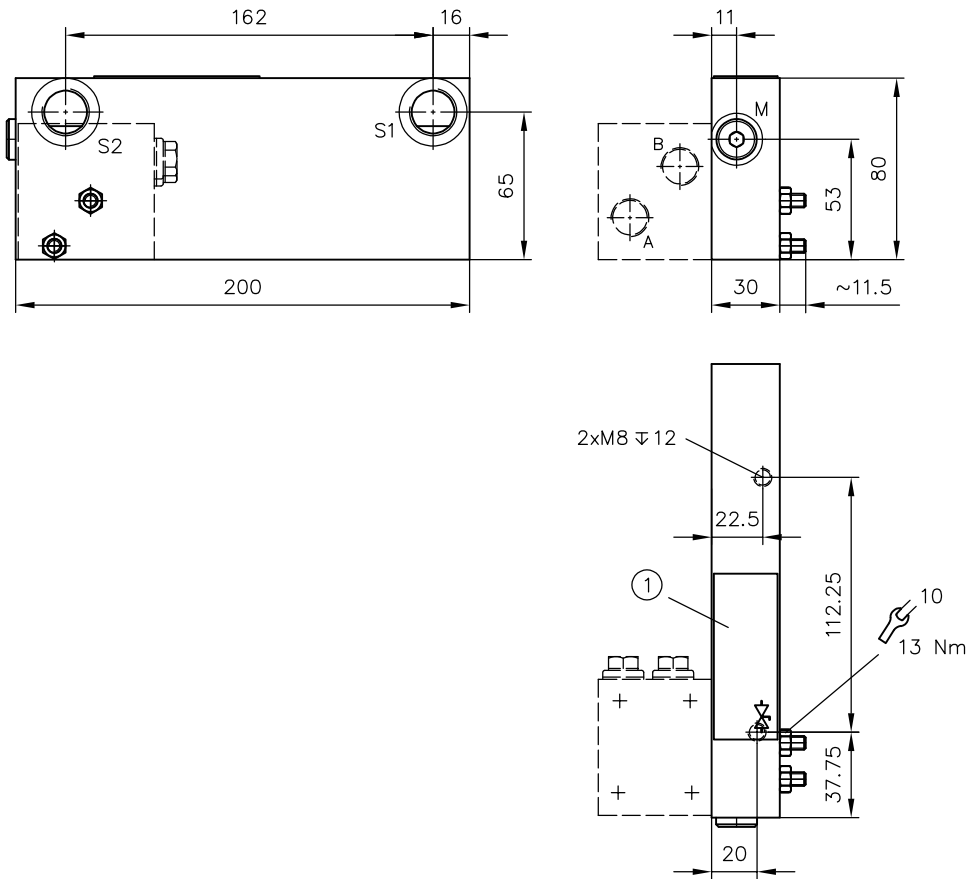

1 Adhesive label only coding 88W

Coding **880/EM 21 D(DS)**, **88W/EM 21 D(DS)**

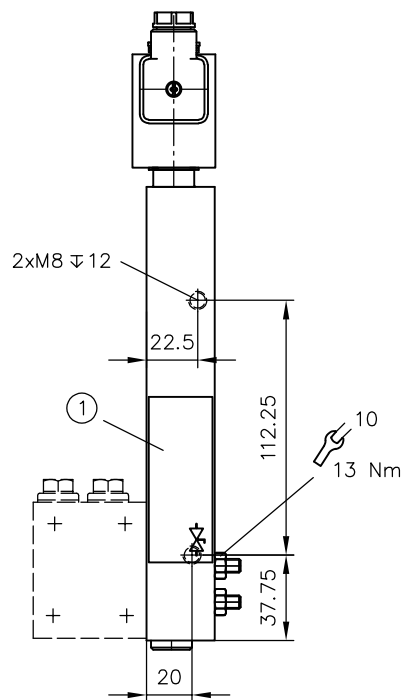
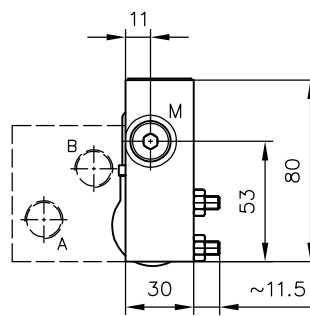
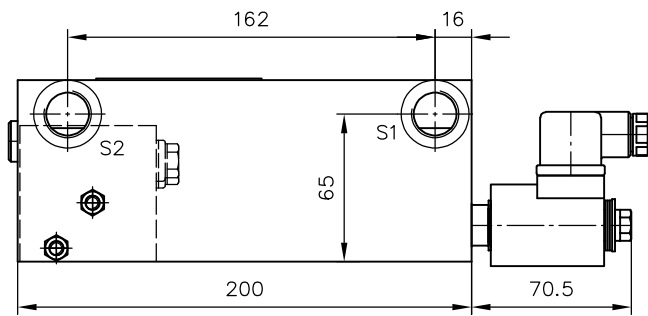

1 Adhesive label only coding 88W/EM(P) 21 D(DS)

Ports (ISO 228-1)	
M	G 1/4
S1, S2	G 1/2

### Extension

Coding 1

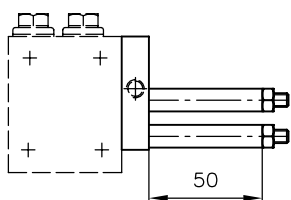

Coding 2

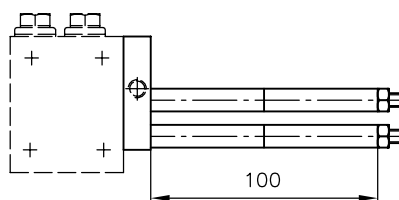

Observe the document B 5488 "General operating instructions for assembly, commissioning, and maintenance."

### 5.1 Intended use

This product is intended exclusively for hydraulic applications (fluid technology).

The user must observe the safety measures and warnings in this document.

**Essential requirements for the product to function correctly and safely:**

- ▶ All information in this documentation must be observed. This applies in particular to all safety measures and warnings.
- ▶ The product must only be assembled and put into operation by specialist personnel.
- ▶ The product must only be operated within the specified technical parameters described in detail in this document.
- ▶ All components must be suitable for the operating conditions when using an assembly.
- ▶ The operating instructions for the components, assemblies and the specific complete system must also always be observed.

**If the product can no longer be operated safely:**

1. Remove the product from operation and mark it accordingly.
  - ✓ It is then not permitted to continue using or operating the product.

### 5.2 Assembly information

The product must only be installed in the complete system with standard and compliant connection components (screw fittings, hoses, pipes, fixtures etc.).

The product must be shut down correctly prior to disassembly (in particular in combination with hydraulic accumulators).

**⚠ DANGER**  
**Sudden movement of the hydraulic drives when disassembled incorrectly**  
 Risk of serious injury or death

- ▶ Depressurise the hydraulic system.
- ▶ Perform safety measures in preparation for maintenance.

#### 5.2.1 Maximum adjustment travel of the throttle screw

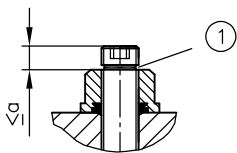

1 Red ring

When the throttle screw has been unscrewed to the extent of the maximum permissible adjustment travel (general figure  $a_{max} = 5 \text{ mm}$ ), a red marker ring is visible. The maximum adjustment travel must not be exceeded, because

- unscrewing further does not achieve any further change in the flow cross section that influences the  $\Delta p$  value.
- at high pressures there is a risk that the throttle screw will be ripped out (because there are too few turns of the thread engaged).

This risk must be pointed out in the operating manual or operating instructions for the system:

**⚠ DANGER**  
**Sudden movement of the hydraulic drives.**  
 Risk of serious injury or death.

- Do not unscrew the throttle screw via the red marking ring.

### Adjusting the throttle screw

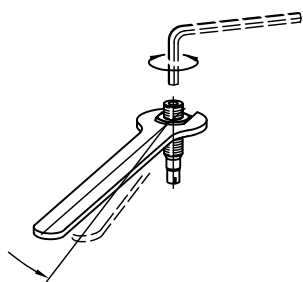

To avoid leakage of oil, proceed as follows:

1. Slightly slacken the seal-lock nut (17 mm).
2. Use a hex wrench (5 mm) to adjust the throttle screw.
3. Tighten the seal-lock nut.

## 5.3 Operating instructions

Observe product configuration and pressure/flow rate.

The statements and technical parameters in this document must be strictly observed.

The instructions for the complete technical system must also always be followed.

### ! NOTICE

- ▶ Read the documentation carefully before usage.
- ▶ The documentation must be accessible to the operating and maintenance staff at all times.
- ▶ Keep documentation up to date after every addition or update.

### ⚠ CAUTION

#### **Overloading components due to incorrect pressure settings.**

Risk of minor injury. Parts may burst or fly off, and uncontrolled leakage of hydraulic fluid.

- Pay attention to the maximum operating pressure of the pump, valves and fittings.
- Always monitor the pressure gauge when setting and changing the pressure.

## Purity and filtering of the hydraulic fluid

Fine contamination can significantly impair the function of the product. Contamination can cause irreparable damage.

### Examples of fine contamination include:

- Swarf
- Rubber particles from hoses and seals
- Dirt due to assembly and maintenance
- Mechanical debris
- Chemical ageing of the hydraulic fluid

### ! NOTICE

#### **New hydraulic fluid from the manufacturer may not have the required purity.**

Damage to the product is possible.

- ▶ Filter new hydraulic fluid to a high quality when filling.
- ▶ Do not mix hydraulic fluids. Always use hydraulic fluid that is from the same manufacturer, of the same type, and with the same viscosity properties.

For smooth operation, pay attention to the cleanliness level of the hydraulic fluid (cleanliness level see Chapter 3, "Parameters").

Additionally applicable document: [D 5488/1](#) oil recommendations

## 5.4 Maintenance information

Check regularly (at least once a year) by visual inspection whether the hydraulic connections are damaged. If external leakages are found, shut down and repair the system.

Clean the surface of the device regularly (at least once a year) (dust deposits and dirt).

## 6 Other information

### 6.1 Circuit example

#### Ordering example:

Combination with compact hydraulic power pack type HKF to D 7600-4

HKF 449 D/1 M - Z12,3	- AL 21 F2 - BA 2	- E50/60 - 5/150 - NSMD 2 K/GRK/B1,0/0 - NSMD 2 K/GRK/B1,0/0 - NSWP 2 G/02/B1,0/0 - 8 - G 24 - AC 2001
-----------------------	----------------------	--

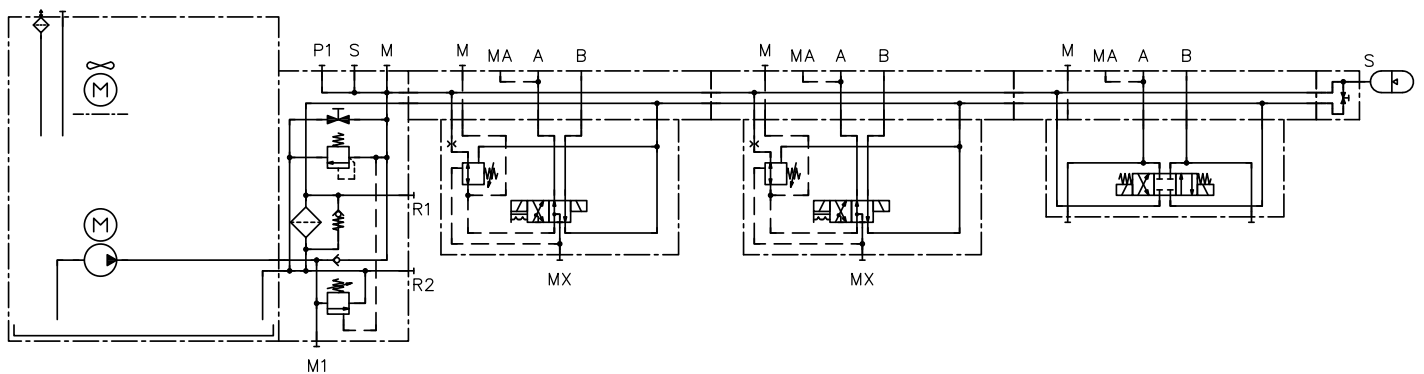
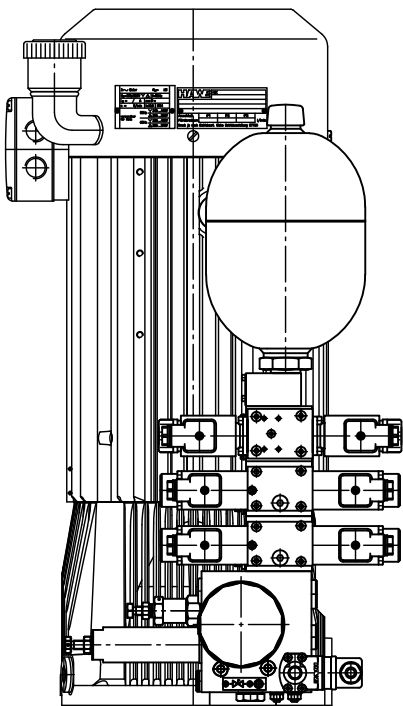

## 6.2 Accessories, spare and individual parts

To purchase spare parts, please see [HAWE Hydraulik interactive contact map](#).

### Order coding

Type / Coding	Designation	Order number
XP, XR	Disc	6905 018
XP 0.5, XR 0.5	Orifice disc	6905 018-0,5
XP 0.6, XR 0.6		6905 018-0,6
XP 0.8, XR 0.8		6905 018-0,8
XP 1.0, XR 1.0		6905 018-1,0
XP 1.5, XR 1.5		6905 018-1,5
XP 2.0, XR 2.0		6905 018-2,0
XP 2.5, XR 2.5		6905 018-2,5
XP 3.0, XR 3.0		6905 018-3,0
.1, .2	Spacer sleeve	7788 016

## References

### Additional versions

- Compact hydraulic power pack type KA and KAW size 2: D 8010
- Compact hydraulic power packs type KA size 4: D 8010-4
- Compact hydraulic power pack type INKA 1: D 8132-1
- Compact hydraulic power pack type MPN and MPNW: D 7207
- Compact hydraulic power pack type HK 3: D 7600-3
- Compact hydraulic power pack type HKL and HKLW: D 7600-3L
- Compact hydraulic power pack type HK 4: D 7600-4
- Hydraulic power pack type FXU: D 6020
- Connection blocks for single-circuit pumps types AB, AL: D 6905 AB
- Valve bank (directional seated valve) type VB: D 7302
- Valve bank (directional seated valve) type BWN and BWH: D 7470 B/1
- Valve bank type BNG: D 7788 BNG
- Valve bank (directional seated valve) type BVH: D 7788 BV
- Directional seated valve type NBVP 16: D 7765 N
- 4/2- and 4/3-way directional spool valves type SWPM (SAM, SBM, SCM): D 6420/1
- Directional spool valve type NSWP 2: D 7451 N
- Directional spool valve type CWPN: D 7451 CWPN
- Directional seated valve type ROLV: D 8144
- Proportional pressure-limiting valve type NPMVP: D 7485 N
- Clamping module type NSMD: D 7787
- Intermediate plate type NZP: D 7788 Z
- Directional spool valve type SG and SP: D 5650/1
- Fitting type X 84: D 7077
- Diaphragm accumulator type AC: D 7969
- Miniature accumulator type AC: D 7571

