

Radial piston pump type R, RG

Product documentation



Operating pressure p_{\max} :	700 bar
Displacement volume $V_{g \max}$:	64.2 cm ³ /rev
Flow rate Q_{\max} :	91.2 l/min



© by HAWE Hydraulik SE.

The reproduction and distribution of this document, as well as the use and communication of its contents to others without explicit authorization, is prohibited.

Offenders will be held liable for the payment of damages.

All rights reserved in the event of patent or utility model applications.

Brand names, product names and trademarks are not specifically indicated. In particular with regard to registered and protected names and trademarks, usage is subject to legal provisions.

HAWE Hydraulik respects these legal provisions in all cases.

HAWE Hydraulik cannot provide individual guarantees that the stated circuits or procedures (including in part) are not subject to the intellectual property rights of third parties.

Printing date / document generated on: 2026-02-11

Table of Contents

1	Overview of radial piston pump type R, RG.....	4
1.1	Design.....	4
1.2	Assemblies.....	4
1.3	Sectional model of a double radial pump (assembly 6012).....	5
2	Available versions.....	6
2.1	Basic type.....	6
2.2	Delivery flow coding.....	7
2.3	Versions.....	10
2.4	Seals.....	10
2.5	Supplement.....	10
3	Parameters.....	11
3.1	General data.....	11
3.2	Pressure and volumetric flow.....	12
3.3	Weight.....	12
3.4	Characteristic lines.....	13
4	Dimensions.....	14
4.1	Assembly 7631.....	14
4.2	Assembly 6010.....	15
4.3	Assembly 6011.....	16
4.4	Assembly 6012.....	16
4.5	Assembly 6014.....	17
4.6	Assembly 6016.....	18
5	Installation, operation and maintenance information.....	19
5.1	Intended use.....	19
5.2	Assembly information.....	19
5.2.1	Venting and commissioning.....	19
5.2.2	Version for slightly charged pumps (above approx. 0.4 to 0.5 bar).....	20
5.3	Operating instructions.....	20
5.4	Maintenance information.....	21
6	Other information.....	22
6.1	Accessories, spare and individual parts.....	22
6.2	Power consumption of the motor.....	22

1 Overview of radial piston pump type R, RG

Pump elements deliver lubricating hydraulic fluids while simultaneously generating a counter-pressure opposing the load resistance of a connected consumer.

The radial piston pump type R and RG is versatile and can be used not only as a motor pump outside an oil tank but also for installation in the tank of a hydraulic power pack (see D 6010 H).

The pumps are generally used to supply hydraulic oil to hydraulic consumers in oil-hydraulic systems. Maximum installable capacity of up to 30 kW, depending on size.

The radial piston pump type RG has plain bearings which have a longer service life. This type is therefore used in extreme operating conditions.

Extremely high flow rates can also be achieved by arranging up to 6 radials in parallel.

Features and advantages

- Good function even at low viscosity
- High level of efficiency
- Compact dimensions
- Fine flow rate gradation

Intended applications

- Any high-pressure application is basically possible.
- Areas in which a constant flow rate is necessary.
- Press construction
- Fixture design
- Testing and laboratory equipment
- Lubrication systems
- Agricultural engineering



Radial piston pump type R, RG

1.1 Design

The radial piston pumps are valve-controlled with cylinders in a radial arrangement. The cylinder radials, arranged in one, two or more superimposed layers (rows), are driven by bearings fitted eccentrically on the drive shaft (piston pressure stroke), and reset by springs (piston suction stroke). The flow rates of the individual cylinders are brought together in collecting plates feeding a joint pressure connection. The housing shells are load-bearing elements supporting the cylinders and shaft bearings. The pumps are largely statically and dynamically balanced, resulting in smooth running. With the exception of the 1 and 2-cylinder pumps, an uneven number of pistons is used per cylinder radial, so that the pulsation of the flow rate is minimised from three cylinders upwards.

1.2 Assemblies

7631

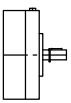

6010

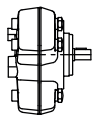

6011

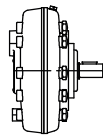

6012

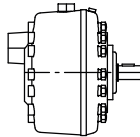

6014

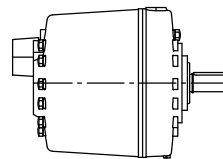

6016

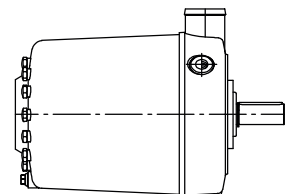

Type MPE.. cylinders are installed in assembly 7631. All other assemblies (type 6010 – 6016) are fitted with type PE.. cylinders.

1.3 Sectional model of a double radial pump (assembly 6012)

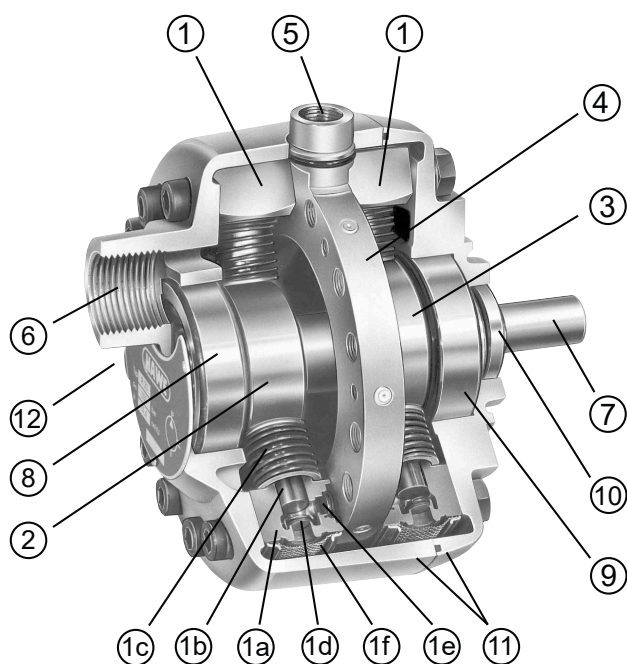

- 1 Pump cylinder, consisting of:
 - 1a Cylinder
 - 1b Piston
 - 1c Return spring for the suction stroke
 - 1d Integrated suction valve
 - 1e Integrated pressure valve
 - 1f Strainer insert, protects against coarse contamination
- 2 Rear eccentric bearing for the pressure stroke
- 3 Front eccentric bearing for the pressure stroke
- 4 Hydraulic oil manifold
- 5 Hydraulic oil outlet (pressure connection)
- 6 Suction port
- 7 Drive shaft
- 8 Rear shaft bearing
- 9 Front shaft bearing
- 10 Shaft seal
- 11 Housing
- 12 Type plate

2 Available versions

Circuit symbol

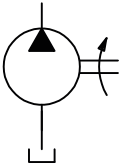

Ordering example

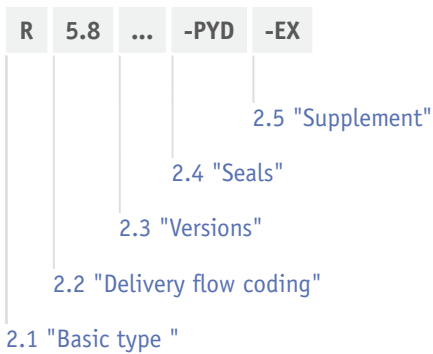

2.1 Basic type

Type	Description
R	<ul style="list-style-type: none"> Series Version with roller bearing as eccentric bearing Also suitable for lowest rotation speeds
RG	<ul style="list-style-type: none"> Version with plain bearings as eccentric bearing Highly suitable for media with low lubricity (e.g. HFC) Not suitable for low rotation speeds as the necessary lubricating film cannot then be established Not available for assembly 7631

Where the load duration is between 75% and 100% in successive work cycles, e.g. accumulator charging mode or similar, the maximum permissible operating pressure should not be fully utilised in order to preserve an economical bearing service life. It is better to select a pump with a similar displacement volume and smaller piston diameter.

2.2 Delivery flow coding

i INFORMATION

- The optimum area of application of the radial piston pump type R, RG is at a rotation speed of approx. 1450 min⁻¹.
- Individual variants can be operated at up to 3600 min⁻¹; see the column Flow rate (l/min) at 3600 min⁻¹, but not in conjunction with HFA version.
- Increase in the rotation speed results in a reduction in service life.

Coding delivery flow (l/min) at 1450 min ⁻¹	Displacement volume V _g (cm ³ /rev)	Operating pressure / operating pressure HFA version p _{max} (bar)	Assembly	Pump elements		Power range of motor (kW)	Flow rate (l/min) at 3600 min ⁻¹
				Number	Piston Ø (mm)		
0.18	0.13	700	7631	2	4	0.25 - 0.55	--
0.27	0.19	700	7631	3	4	0.25 - 0.75	--
0.28	0.2	550	7631	2	5	0.25 - 0.55	--
0.3	0.21	700 / 525	6010	1	6	0.25 - 2.2	0.74
0.41	0.29	700 / 450	6010	1	7	0.25 - 2.2	1.02
0.42	0.29	550	7631	3	5	0.25 - 0.75	--
0.43	0.28	450	7631	2	6	0.25 - 0.55	--
0.46	0.31	700	7631	5	4	0.25-1.5	--
0.5	0.38	700 / 410	6010	1	8	0.25 - 2.2	--
0.56	0.38	350	7631	2	7	0.25 - 0.55	--
0.6	0.43	700 / 525	6010	2	6	0.25 - 2.2	1.49
0.64	0.42	450	7631	3	6	0.25 - 0.75	--
0.7	0.49	550	7631	5	5	0.25-1.5	--
0.73	0.5	300	7631	2	8	0.25 - 0.55	--
0.8	0.6	500 / 335	6010	1	10	0.25 - 2.2	--
0.81	0.58	350	7631	3	7	0.25 - 0.75	--
0.83	0.58	700 / 450	6010	2	7	0.25 - 2.2	2.06
0.9	0.64	700 / 525	6010	3	6	0.25 - 3	2.23
0.92	0.64	250	7631	2	9	0.25 - 0.55	--
1	0.76	700 / 410	6010	2	8	0.25 - 2.2	--
1.08	0.71	450	7631	5	6	0.25-1.5	--
1.1	0.75	300	7631	3	8	0.25 - 0.75	--
1.2	0.86	350 / 260	6010	1	12	0.25 - 2.2	--
1.25	0.88	700 / 450	6010	3	7	0.25 - 3	3.10
1.35	0.95	250	7631	3	9	0.25 - 0.75	--
1.39	0.96	350	7631	5	7	0.25-1.5	--
1.4	1.07	700 / 525	6011	5	6	0.25 - 4	3.47
1.45	1.01	300	6010	1	13	0.25 - 2.2	--
1.5	1.15	700 / 410	6010	3	8	0.25 - 3	--
1.6	1.19	500 / 335	6010	2	10	0.25 - 2.2	--
1.7	1.17	250	6010	1	14	0.25 - 2.2	--
1.77	1.26	300	7631	5	8	0.25-1.5	--

Coding delivery flow (l/min) at 1450 min ⁻¹	Displacement volume V _g (cm ³ /rev)	Operating pressure / operating pressure HFA version p _{max} (bar)	Assembly	Pump elements		Power range of motor (kW)	Flow rate (l/min) at 3600 min ⁻¹
				Number	Piston ∅ (mm)		
1.9	1.34	200	6010	1	15	0.25 - 2.2	--
2.08	1.46	700 / 450	6011	5	7	0.25 - 4	--
2.1	1.5	700 / 525	6011	7	6	0.55 - 5.5	--
2.2	1.53	200	6010	1	16	0.25 - 2.2	--
2.27	1.59	250	7631	5	9	0.25-1.5	--
2.4	1.72	350 / 260	6010	2	12	0.25 - 2.2	--
2.5	1.79	500 / 335	6010	3	10	0.25 - 3	--
2.6	1.91	600 / 410	6011	5	8	0.25 - 4	--
2.7	2.15	700 / 525	6012	10	6	2.2 - 7.5 (9)	6.70
2.8	2.02	300	6010	2	13	0.25 - 2.2	--
2.9	2.05	600 / 450	6011	7	7	0.55 - 5.5	--
3.3	2.34	250	6010	2	14	0.25 - 2.2	--
3.6	2.58	350 / 260	6010	3	12	0.25 - 3	--
3.7	2.67	550 / 410	6011	7	8	0.55 - 5.5	--
3.8	2.69	200	6010	2	15	0.25 - 2.2	--
4	3.01	700 / 525	6012	14	6	2.2 - 11	--
4.15	2.92	700 / 450	6012	10	7	2.2 - 7.5 (9)	--
4.2	2.98	450 / 335	6011	5	10	0.25 - 4	--
4.3	3.03	300	6010	3	13	0.25 - 3	--
4.4	3.06	200	6010	2	16	0.25 - 2.2	--
5.1	3.51	250	6010	3	14	0.25 - 3	--
5.3	3.82	600 / 410	6012	10	8	2.2 - 7.5 (9)	--
5.6	4.03	200	6010	3	15	0.25 - 3	--
5.8	4.18	450 / 335	6011	7	10	0.55 - 5.5	--
5.85	4.09	600 / 450	6012	14	7	2.2 - 11	--
6	4.3	350 / 260	6011	5	12	0.25 - 4	--
6.1	4.3	700 / 525	6014	20	6	5.5 - 18.5	15.13
6.5	4.58	200	6010	3	16	0.25 - 3	--
7	5.04	300	6011	5	13	0.25 - 4	--
7.4	5.35	550 / 410	6012	14	8	2.2 - 11	--
8	6.02	700 / 525	6014	28	6	5.5 - 22	19.84
8.2	5.97	450 / 335	6012	10	10	2.2 - 7.5 (9)	--
8.3	5.85	250	6011	5	14	0.25 - 4	--
8.35	5.85	700 / 450	6014	20	7	5.5 - 18.5	20.71
8.4	6.02	350 / 260	6011	7	12	0.55 - 5.5	--
9.5	6.72	200	6011	5	15	0.25 - 4	--
9.8	7.06	30	6011	7	13	0.55 - 5.5	--
10.9	7.64	160	6011	5	16	0.25 - 4	--
11	7.64	700 / 450	6014	20	8	5.5 - 18.5	--

Coding delivery flow (l/min) at 1450 min ⁻¹	Displacement volume V _g (cm ³ /rev)	Operating pressure / operating pressure HFA version p _{max} (bar)	Assembly	Pump elements		Power range of motor (kW)	Flow rate (l/min) at 3600 min ⁻¹
				Number	Piston ∅ (mm)		
11.6	8.36	450 / 335	6012	14	10	2.2 - 11	--
11.65	8.19	700 / 450	6014	28	7	5.5 - 22	--
11.8	8.19	250	6011	7	14	0.55 - 5.5	--
12	8.6	350 / 260	6012	10	12	2.2 - 7.5 (9)	--
12.7	9.03	700 / 525	6016	42	6	11 - 30	31.50
13.3	9.4	200	6011	7	15	0.55 - 5.5	--
14.2	10.09	300	6012	10	13	2.2 - 7.5 (9)	--
15	10.7	600 / 410	6014	28	8	5.5 - 22	--
15.3	10.7	160	6011	7	16	0.55 - 5.5	--
16.8	11.7	250	6012	10	14	2.2 - 7.5 (9)	--
17	12.03	350 / 260	6012	14	12	2.2 - 11	--
17.4	11.94	500 / 335	6014	20	10	5.5 - 18.5	--
17.45	12.28	700 / 450	6016	42	7	11 - 30	43.28
19.3	13.43	200	6012	10	15	2.2 - 7.5 (9)	--
20	14.12	300	6012	14	13	2.2 - 11	--
21.7	15.28	160	6012	10	16	2.2 - 7.5 (9)	--
22	16.04	700 / 410	6016	42	8	11 - 30	--
23 *	16.71	450 / 335	6014	28	10	5.5 - 22	--
23.5	16.38	250	6012	14	14	2.2 - 11	--
25	17.19	350 / 260	6014	20	12	5.5 - 18.5	--
26.5	18.8	200	6012	14	15	2.2 - 11	--
30	20.18	300	6014	20	13	5.5 - 18.5	--
30.4	21.39	160	6012	14	16	2.2 - 11	--
34 *	24.07	350 / 260	6014	28	12	5.5 - 22	--
34.5	25.07	500 / 335	6016	42	10	11 - 30	--
35	23.4	250	6014	20	14	5.5 - 18.5	--
38	26.86	250	6014	20	15	5.5 - 18.5	--
40 *	28.24	300	6014	28	13	5.5 - 22	--
43.4	30.56	200	6014	20	16	5.5 - 18.5	--
47 *	32.76	250	6014	28	14	5.5 - 22	--
51	36.1	350 / 260	6016	42	12	11 - 30	--
53 *	37.6	200	6014	28	15	5.5 - 22	--
60	42.37	300	6016	42	13	11 - 30	--
60.8 *	42.79	160	6014	28	16	5.5 - 22	--
70 *	49.14	250	6016	42	14	11 - 30	--
80	56.41	200	6016	42	15	11 - 30	--
91.2	64.18	200	6016	42	16	11 - 30	--

* Pump type not suitable for continuous operation. Calculations can be performed by indicating the working cycle.

i **INFORMATION**

The variants shown display a wide range of possible versions. Further combinations are available upon request.

i **INFORMATION**

Since the service life of a hydraulic pump is affected by a wide range of factors, it can only be calculated approximately. Operating pressure, rotation speed, flow rate, working cycle, selection and purity of the hydraulic fluid, temperatures and environmental conditions are key variables.

2.3 Versions

Coding	Description
Without coding	Series
A	Mounting type of the shaft seals, e.g. R 3.6 A (see Chapter 5.2.2, "Version for slightly charged pumps (above approx. 0.4 to 0.5 bar)")
H	Hollow shaft version; available assembly 6010
HFA	Version for water-based media, available assemblies 6010 to 6016; only with piston diameter 6, 7, 8, 10 and 12 see Chapter 3, "Parameters", "Hydraulic fluid", only in combination with type RG

! NOTICE
Due to the operating medium, the maximum operating pressure is reduced, see Chapter 2.2, "Delivery flow coding". For more information on the maximum rotation speed, see Chapter 3.1, "General data".

2.4 Seals

Coding	Description
Without coding	NBR series
PYD	FKM seals (VITON)
AT	EPDM seals

2.5 Supplement

Coding	Description
Without coding	Series
EX	Explosion-proof version (other applicable document to be noted: B ATEX)
HC	Hard coat (housing) Only in conjunction with type RG and version HFA

3 Parameters

3.1 General data

i INFORMATION

The following conditions may result in efficiency losses:

- Viscosities > 500 mm²/s and < 10 mm²/s
- Operating pressures < 20 bar
- Rotation speeds > 2000 min⁻¹; especially with a small piston diameter

Designation	Radial piston pump, constant pump
Attachment	On the front side via the flange
Installation position	Horizontal to vertical; see also D 6010 H
Line connection	Pipe thread ISO 228-1, port sizes see Chapter 4, "Dimensions"
Drive	Via flexible coupling
Rotation direction	As desired
Speed range (min ... max)	<p>Continuous:</p> <ul style="list-style-type: none"> ▪ R = 100 to 2000 min⁻¹ ▪ RG = 1000 to 2000 min⁻¹ <p>2800 min⁻¹ admissible for brief periods, please note in this connection that bell housings, flanges, couplings etc. (D 6010 H) are only available for standard motor sizes 71 to 132 M. The assigned motor power in accordance with DIN 42677 applies to the standard range, see Chapter 2.2, "Delivery flow coding". If the motor is used under increased speed conditions, a reduction of the maximum pump pressure should be expected, see Chapter 6.2, "Power consumption of the motor". Defined pump types permissible up to 3600 min⁻¹, see Chapter 2.2, "Delivery flow coding", however not in conjunction with HFA version.</p>
Flow direction	Determined by suction and pressure connection, independent of the rotation direction
Hydraulic fluid	<p>Hydraulic fluid, according to DIN 51524 Parts 1 to 3; ISO VG 10 to 68 according to DIN ISO 3448 Optimal operating range: approx. 10 - 500 mm²/s</p> <p>Viscosity range:</p> <ul style="list-style-type: none"> ▪ R 0.18 to R 2.27: 4 - 800 mm²/s ▪ R 0.3 to R 91.2: 4 - 1500 mm²/s <div style="border: 1px solid black; padding: 5px; margin-top: 10px;"> <p>! NOTICE Viscosity range for pumps up to 3600 min⁻¹ : 5 - 250 mm²/s.</p> </div> <p>Also suitable for biologically degradable hydraulic fluids type HEPG (polyalkylene glycol) and HEES (synthetic ester) at operating temperatures up to approx. +70°C.</p> <p>Version type R..-HFA is also suitable for water-based hydraulic fluids. Due to the limited lubricity of the hydraulic fluid, the pump should only be operated in standby mode in order to preserve a reasonable service life. The maximum operating pressure should not exceed approx. 75% of the specified p_{max}, see Chapter 2.2, "Delivery flow coding".</p>

Cleanliness level	ISO 4406 <hr/> 21/18/15...19/17/13 see oil recommendation D 5488/1
Temperatures	Environment: approx. -40 to +80 °C, hydraulic fluid: -25 to +80 °C, pay attention to the viscosity range. Start temperature: down to -40 °C is permissible (take account of the start viscosities!), as long as the steady-state temperature is at least 20 K higher during subsequent operation. Biologically degradable hydraulic fluids: note manufacturer specifications. With consideration for the seal compatibility, not above +70°C.

3.2 Pressure and volumetric flow

Operating pressure	Pressure side (outlet): depending on piston diameter, see Chapter 2, "Available versions" Suction side: - 0.3 bar to + 1 bar (approx. 0.7 bar abs. to approx. 2 bar abs.) + 2 bar (3 bar abs.) with type R(G) ... - A, see Chapter 5.2.2, "Version for slightly charged pumps (above approx. 0.4 to 0.5 bar)"
Flow rate	see Chapter 2.2, "Delivery flow coding" Reference value depending on rotation speed: $Q_{Pu} = V_g n \cdot \eta_{Vol} \cdot 10^{-3} \text{ l/min}$ where: V_g in cm ³ /rev Displacement volume, see Chapter 2.2, "Delivery flow coding" n in min ⁻¹ rotation speed $\eta_{Vol} \approx 0.98$ volumetric efficiency

3.3 Weight

Assembly	Number of cylinders	
7631	2	= 3.0 kg
	3	= 3.1 kg
	5	= 3.2 kg
6010	1	= 2.8 kg
	2	= 2.5 kg
	3	= 3.1 kg
6011	5	= 5.6 kg
	7	= 5.8 kg
6012	10	= 8.7 kg
	14	= 10.5 kg
6014	20	= 21.5 kg
	28	= 24.2 kg
6016	42	= 39.1 kg

3.4 Characteristic lines

Running noise

The specified noise level ranges include the results obtained from practical measurements in a test workroom with the identifiable scattering. Pumps with small flow rates (smaller piston diameters) within an assembly usually tend to be in the lower range, pumps with larger flow rates (13 to 16 mm piston diameters) are usually closer to the middle to upper range.

Measuring conditions: quiet workroom with noise level at approx. 37 dB (A); measured 1 m above the ground and 1 m away from the object

Measurement device: precision noise level measurement device DIN IEC 651 Class I

Viscosity of the hydraulic fluid: approx. 50 mm²/s

Assembly 7631

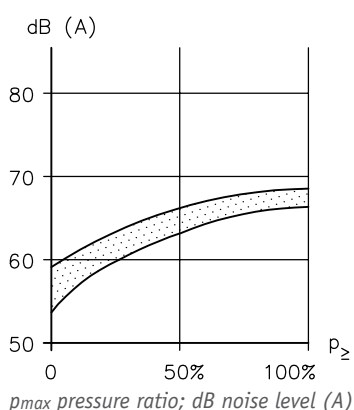

Assembly 6010

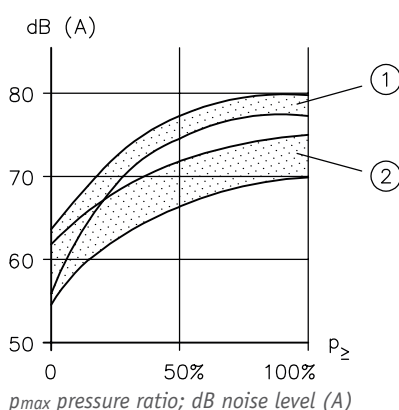

- 1 1-cylinder pump
- 2 2-cylinder pump

Assembly 6011

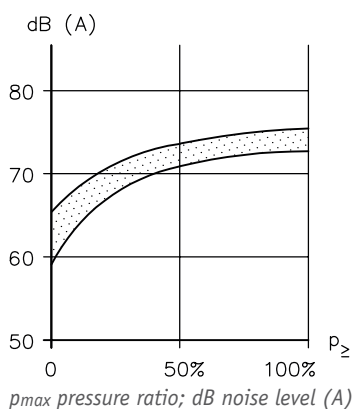

Assembly 6012

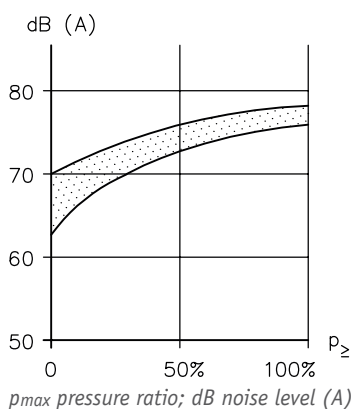

Assembly 6014

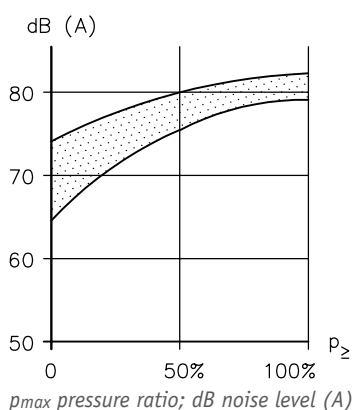

Assembly 6016

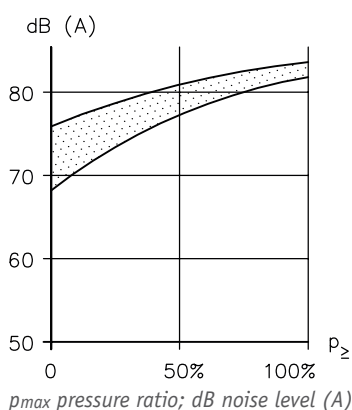

4 Dimensions

All dimensions in mm, subject to change.

4.1 Assembly 7631

2, 3, and 5-cylinder pump

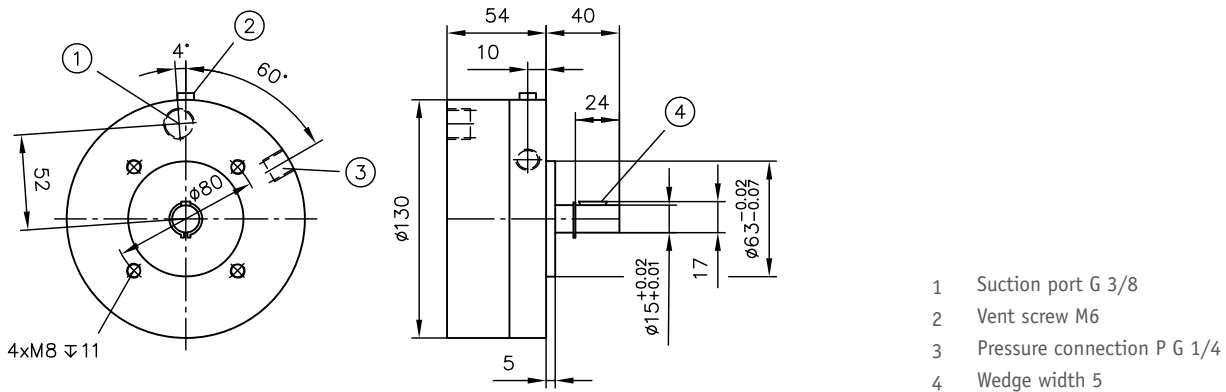

4.2 Assembly 6010

1 and 2-cylinder pump

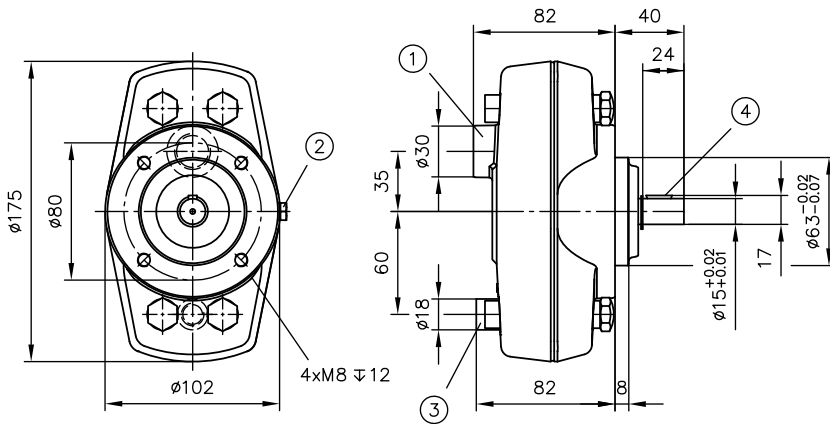

- 1 Suction port G 1/2
- 2 Vent screw M6
- 3 Pressure connection P G 1/4
- 4 Wedge width 5

3-cylinder pump



- 1 Suction port G 1/2
- 2 Vent screw M6
- 3 Pressure connection P G 1/4
- 4 Wedge width 5

2(3)-cylinder pump

Coding H

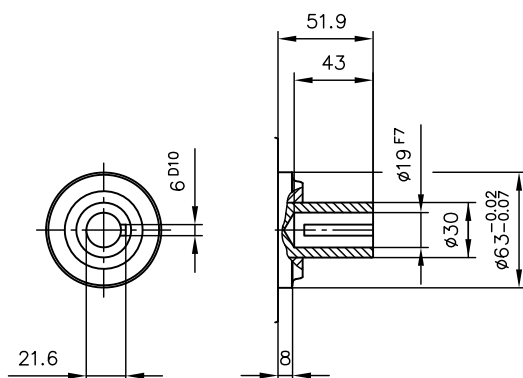

4.5 Assembly 6014

4-radial pump

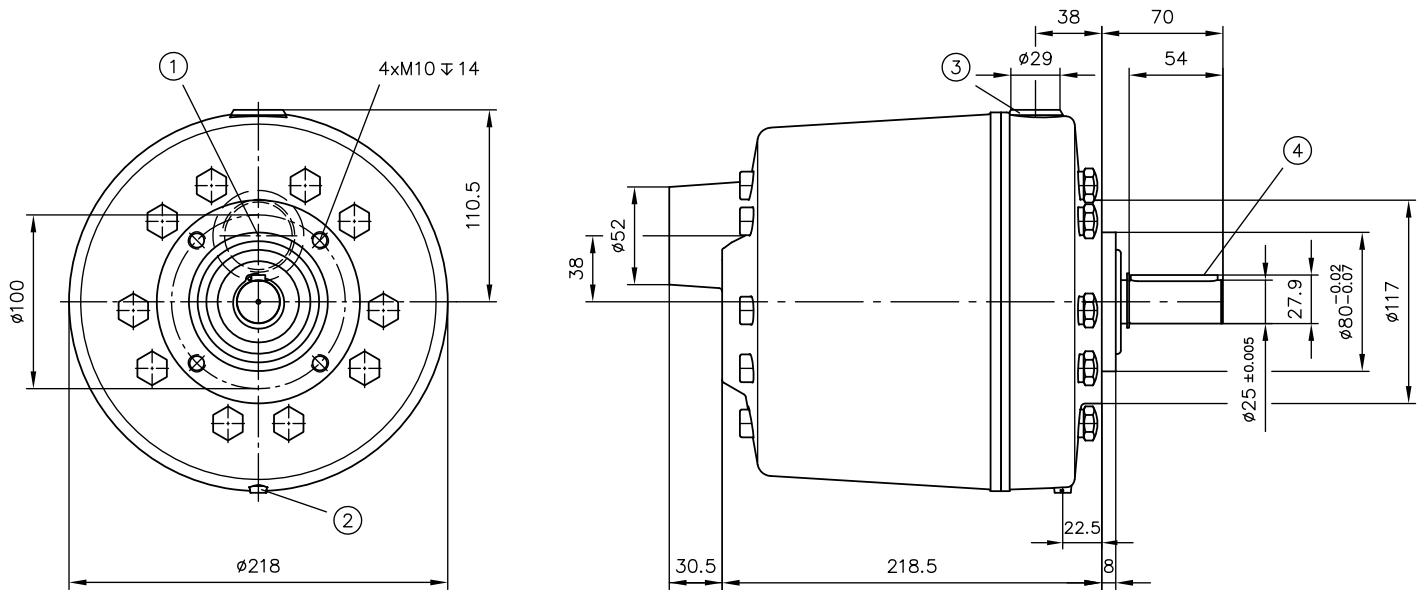

- 1 Suction port G 1 1/4
- 2 Vent screw M6
- 3 Pressure connection P G 1/2
- 4 Wedge width 8

4.6 Assembly 6016

6-radial pump

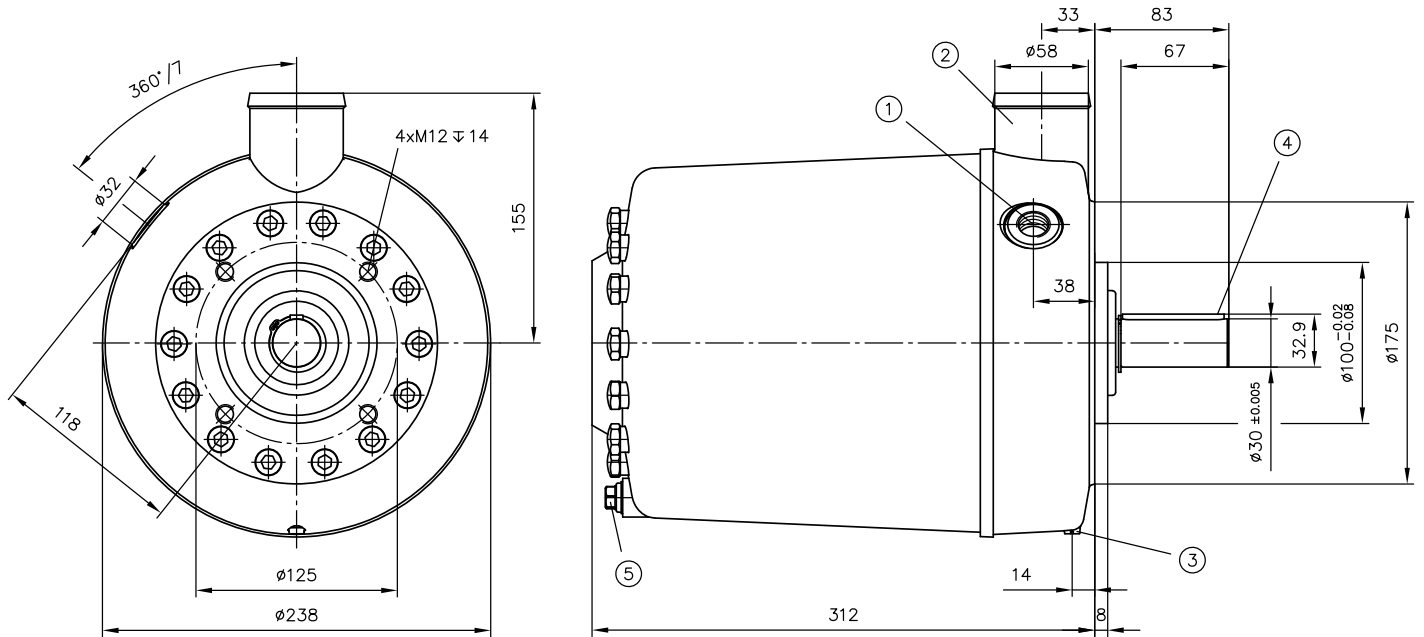

- 1 Pressure connection P
G 1/2 for R 12.7 to R 22.0
G 3/4 for R 34.5 to R 91.2
- 2 Suction port G 1 1/2
- 3 Vent screw M6
- 4 Wedge width 8
- 5 Oil drain screw G 1/4

5 Installation, operation and maintenance information

Observe the document B 5488 "General operating instructions for assembly, commissioning, and maintenance."

Observe the document B 6010 H "Assembly instructions for hydraulic pump / hydraulic power pack type R, RG".

5.1 Intended use

This product is intended exclusively for hydraulic applications (fluid technology).

The user must observe the safety measures and warnings in this document.

Essential requirements for the product to function correctly and safely:

- ▶ All information in this documentation must be observed. This applies in particular to all safety measures and warnings.
- ▶ The product must only be assembled and put into operation by specialist personnel.
- ▶ The product must only be operated within the specified technical parameters described in detail in this document.
- ▶ All components must be suitable for the operating conditions when using an assembly.
- ▶ The operating instructions for the components, assemblies and the specific complete system must also always be observed.

If the product can no longer be operated safely:

1. Remove the product from operation and mark it accordingly.
 - ✓ It is then not permitted to continue using or operating the product.

5.2 Assembly information

The product must only be installed in the complete system with standard and compliant connection components (screw fittings, hoses, pipes, fixtures etc.).

The product must be shut down correctly prior to disassembly (in particular in combination with hydraulic accumulators).



DANGER

Sudden movement of the hydraulic drives when disassembled incorrectly

Risk of serious injury or death

- ▶ Depressurise the hydraulic system.
- ▶ Perform safety measures in preparation for maintenance.

5.2.1 Venting and commissioning

When commissioning the pump for the first time and after each oil change, vent the pumps to prevent problems with the suction and air from entering the consumers. See operating instructions B 6010 H.

5.2.2 Version for slightly charged pumps (above approx. 0.4 to 0.5 bar)

Series

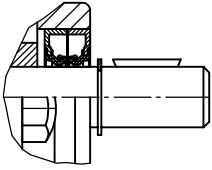

Sealing lips facing each other - no marking

Version R...A

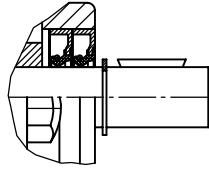

Sealing lips facing inwards for suction pressures exceeding approx. 0.4 bar

The drive shaft is sealed to the outside on the shaft journal by two radial sealing rings arranged one behind the other. The sealing lips are installed as standard so that they face each other. This ensures that, when the pump is operating, no air can penetrate during suction (negative pressure in the pump housing) and no oil can escape outside even if the pump is located underneath the oil tank (slight overpressure in the pump housing due to the weight of the oil column).

For applications where the oil tank is installed much higher than the pump (e.g. several meters) or a closed oil tank is kept (charged) under constant low overpressure $p_s > 0.4$ bar, the pumps can also be supplied with both sealing lips facing inwards.

However, it should be noted that charging pressures above 1 bar (2 to 3 bar still permissible) can greatly reduce the service life of the sealing lips and can only be tolerated in systems with low switching frequency, i.e. long downtimes.

5.3 Operating instructions

Observe product configuration and pressure/flow rate.

The statements and technical parameters in this document must be strictly observed.

The instructions for the complete technical system must also always be followed.

NOTICE

- ▶ Read the documentation carefully before usage.
- ▶ The documentation must be accessible to the operating and maintenance staff at all times.
- ▶ Keep documentation up to date after every addition or update.

CAUTION

Overloading components due to incorrect pressure settings.

Risk of minor injury. Parts may burst or fly off, and uncontrolled leakage of hydraulic fluid.

- Pay attention to the maximum operating pressure of the pump, valves and fittings.
- Always monitor the pressure gauge when setting and changing the pressure.

Purity and filtering of the hydraulic fluid

Fine contamination can significantly impair the function of the product. Contamination can cause irreparable damage.

Examples of fine contamination include:

- Swarf
- Rubber particles from hoses and seals
- Dirt due to assembly and maintenance
- Mechanical debris
- Chemical ageing of the hydraulic fluid

! NOTICE

New hydraulic fluid from the manufacturer may not have the required purity.

Damage to the product is possible.

- ▶ Filter new hydraulic fluid to a high quality when filling.
- ▶ Do not mix hydraulic fluids. Always use hydraulic fluid that is from the same manufacturer, of the same type, and with the same viscosity properties.

For smooth operation, pay attention to the cleanliness level of the hydraulic fluid (cleanliness level see Chapter 3, "Parameters").

Additionally applicable document: [D 5488/1](#) oil recommendations

5.4 Maintenance information

Check regularly (at least once a year) by visual inspection whether the hydraulic connections are damaged. If external leakages are found, shut down and repair the system.

Clean the surface of the device regularly (at least once a year) (dust deposits and dirt).

6 Other information

6.1 Accessories, spare and individual parts

To purchase spare parts, please see [HAWE Hydraulik interactive contact map](#).

- For spare parts (pump elements), please see [D 5600](#).

6.2 Power consumption of the motor

Power consumption:

$$P_{kW} = \frac{p_{bar} \cdot Q_{l/min} \cdot k}{600 \eta_T} \quad \text{Reference value per customary calculation}$$

where:

P_{kW} = required drive power at the pump shaft in kW

p_{bar} = pressure in bar against which the pump should operate
(consumer pressure + flow resistances)

$Q_{l/min}$ = flow rate in l/min, at $1450 \text{ min}^{-1} \approx$ delivery flow coding see [Chapter 2.2, "Delivery flow coding"](#);
at different rotation speeds n_x , $Q_{l/min} \approx$ delivery flow coding multiplied by $n_x / 1450$

k = theoretical factor that takes the pulsation of the pump into account

3 to 42 cylinders: $k = 1$

2-cylinder pump: $k \approx 1.3$ to 1.5

1-cylinder pump: $k \approx 2.7$ to 3.1 (highest value where piston diameter is 12 to 16 mm)

η_T = overall efficiency of the pump ≈ 0.8 to 0.85

i INFORMATION

The overall efficiency of the pump may vary depending on the pump element version.

References

Additional versions

- Motor pump and hydraulic power pack type R and RG: D 6010 H
- Radial piston pump type R and RG with several pressure connections: D 6010 D
- Hydraulic power pack type R and RG: D 6010 DB
- Radial piston pump type R and RG with one main pressure connection and one or two ancillary pressure connections: D 6010 S

