



Hydraulic pilot control valves and Feed units

TECHNICAL CATALOGUE



Additional information

This catalogue shows the product in the most standard configurations.
Please contact our Sales Department for more detailed information or special requests.

WARNING!

All specifications of this catalogue refer to the standard product at this date.
Walvoil, oriented to a continuous improvement, reserves the right to discontinue, modify or revise the specifications, without notice.

**WALVOIL IS NOT RESPONSIBLE FOR ANY DAMAGE CAUSED BY AN
INCORRECT USE OF THE PRODUCT.**

5th edition November 2021

System description page 4

SVM hydraulic joysticks

- Working conditions page 7
 - SVM100 - SVM101 page 8
 - SVM400 - SVM430 series page 16
 - SVM400-EMD page 23
 - Pressure control curves page 27
 - SVM405 page 31
 - Pressure control curves page 35
 - SVM320 page 37
 - Pressure control curves page 41

SVM hydraulic joysticks with differential area

- Working conditions page 41
 - Features page 42
 - SVM980 page 43
 - Pressure control curves page 47
 -

SVM hydraulic joysticks with electromagnetic detent

- Working conditions page 49
 - SVM150 page 50
 - SVM450 page 55
 - SVM600 page 59
 - Pressure control curves page 63

SVM hydraulic joysticks with pedal and other actuations

- Working conditions page 65
 - SVM510 - SVM520 - SVM521 page 66
 - SVM500 series page 70
 - SVM540 series page 75
 - SVM702 - SVM710 page 80
 - Pressure control curves page 82

Feed units and accessories

- Working conditions page 87
 - AVN020 unit page 89
 - FU/1 unit - one stage page 92
 - FU/2 unit - two stages page 93
 - FU/3 unit - three stages page 94
 - FU/4 unit - four stages page 95
 - DHV080 diverter valve page 96

Appendix

- Suggested pressure control curve page 98
 - Installation notes page 99

System description

This is an ideal hydraulic proportional remote control system when max. movement precision and long-lasting reliability are required.

The system needs a secondary circuit with low pressure pilotage, fed separately by a dedicated pump and in derivation to the primary one. In this last case, it is necessary to include a feeding unit with eventual accumulator for emergency interventions into the circuit.

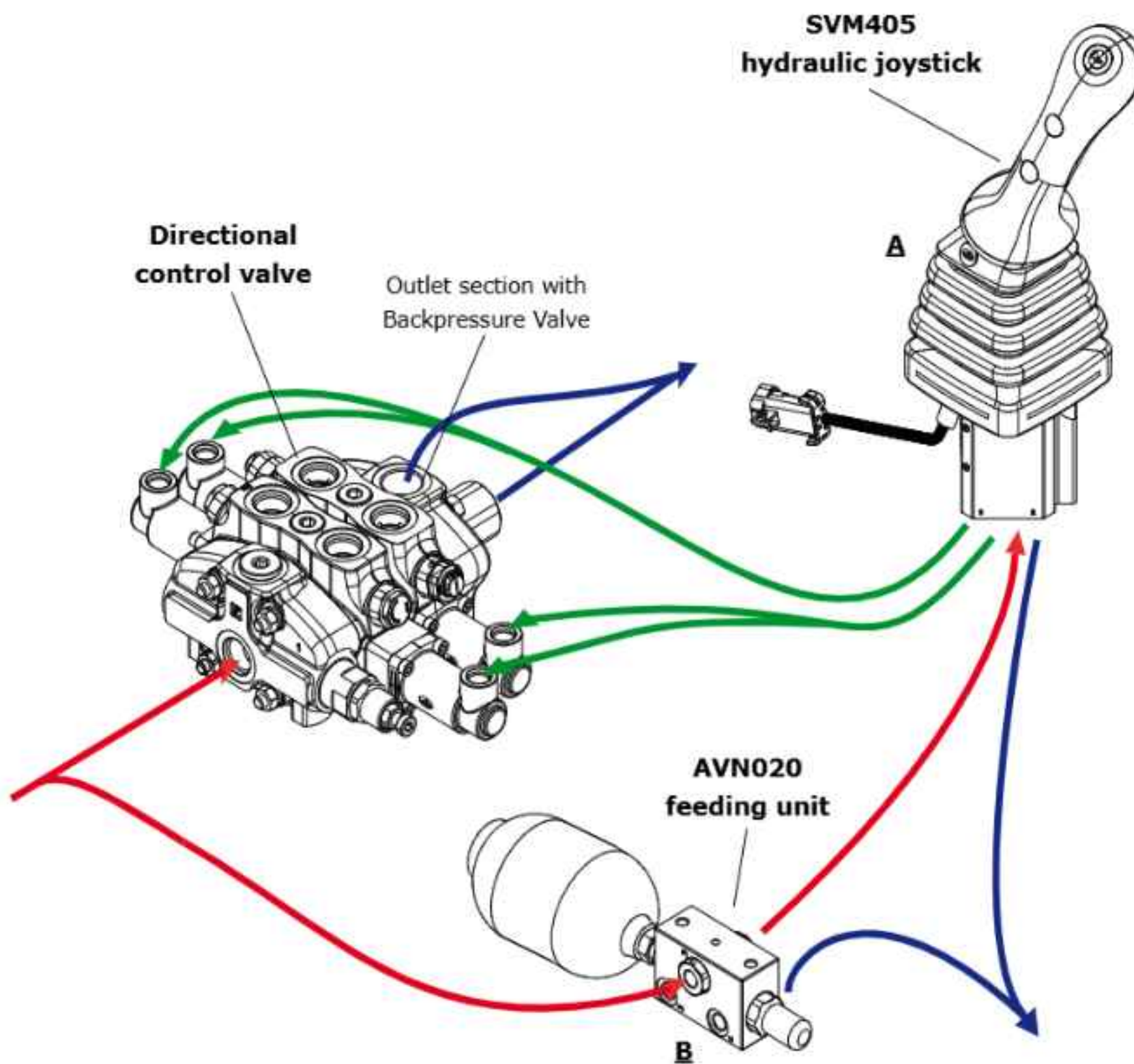

A - SVM hydraulic pilot control valve

Walvoil offers a wide range of hydraulic control valves.

The main product lines are:

1) Hydraulic joysticks

- SVM100 - SVM101

Hydraulic joysticks, single function available with wide range of handles. Hydraulic control valves available single or assembled from 1 to 10 sections.

- SVM400

Hydraulic joystick, double function available with wide range of handles. Single lever joystick to control two directional control valve working sections.

- SVM430 series (SVM430 - SVM431 - SVM432)

Special version operation of translation motors and hydrostatic transmission.

- SVM400-EMD

Single electromagnetic detent on all ports or double on opposite ports.

- SVM405

Configuration with damping system.

- SVM320

Hydraulic joystick with low operating effort.

2) Hydraulic joysticks with differential area

- SVM980

Hydraulic joystick, double function, with low operating effort and possibility to manage and regulate high flow rates.

3) Hydraulic joysticks with electromagnetic detent

- SVM150

Hydraulic joystick, single axis with electromagnetic detent available in every acting directions. It can be assembled up to 5 sections.

- SVM450

Hydraulic joystick, double axis available with a wide range of handles. It can be configured with up to 3 electromagnetic detents.

- SVM600

Combined joystick single axis-double axis for three working sections. It can be configured with up to 4 electromagnetic detents.

4) Hydraulic joysticks with pedal and other actuations

- SVM510 - SVM520 - SVM521

Pedal joystick to control one or two directional control valve working sections, reduced dimensions and weight.

- SVM500 series

Pedal hydraulic pilot valves, available in different configurations. High sensitivity and low force, reduced weight. For agricultural machines and earth moving machines.

- SVM540

Double pedal hydraulic pilot valves for mini-excavator application.

- SVM702 - SVM710

Unit with single work port, handwheel or pusher operating.

B - Feed unit and accessories

Feed unit can be chosen between two distinct series available:

1) AVN020

2 way series with or without unloader valve

2) FU series

Range from 1 to 4 stages, with or without hydraulic accumulator.





SVM hydraulic joysticks

SVM100-SVM101 / SVM400 / SVM430 series/SVM405/ SVM320

- Single and double function
- Special configuration for hydrostatic transmission
- Wide range of handles available

Working conditions

This catalogue shows technical specifications and diagrams measured through mineral oil of 46mm²/s - 46 cSt viscosity at 40°C - 104°F temperature.

Nominal flow rating		from 5 to 20 l/min - from 1.32 to 5.28 USgpm (12 l/min for SVM320 - 3.17 USgpm for SVM320)
Max. feeding pressure	on P inlet port	from 30 to 100 bar - from 435 to 1450 psi
Max. backpressure	on T outlet port	3 bar - 43.5 psi
Max. hysteresis		0.5 bar - 7.25 psi
Internal leakage (all ports)	at 30 bar - 435 psi, P⇒T	from 2.5 to 4.5 cm ³ /min - from 0.15 to 0.27 in ³ /min
Fluid		Mineral oil
Fluid temperature	with NBR (BUNA-N) seals	from -10°C to 80°C - from 14 °F to 176 °F
	operating range	from 15 to 75 mm ² /s - from 15 to 75 cSt
Viscosity	min.	12 mm ² /s - 12 cSt
	max.	400 mm ² /s - 400 cSt
Max. contamination level		-/15/12 - ISO 4406 - NAS1638 class 6
Ambient temperature	without electric devices	from -40°C to 60°C - from 40 °F to 140 °F
	with electric devices	from -20°C to 50°C - from -4 °F to 122 °F
Tie rod tightening torque (wrench 13)	only for SVM100-101	24 Nm - 17.7 lbft

NOTE - for different conditions please contact our Sales Dpt.

REFERENCE STANDARD

	BSP	UN-UNF
THREAD ACCORDING TO	ISO 228/1	ISO 263
	BS 2779	ANSI B1.1 unified
CAVITY DIMENSION ACCORDING TO	ISO 1179	11926
	SAE	J11926
	DIN 3852-2 shape X or Y	

PORT THREADING

PORTS	Threads		Fitting tightening torque	
	UNI EN ISO 1179	UNI EN ISO 11926-2	Nm	lbft
P Inlet	G 1/4	7/16-20 (SAE 4)	30	22.1
Ports	G 1/4	7/16-20 (SAE 4)	30	22.1
T Outlet	G 1/4	7/16-20 (SAE 4)	30	22.1

NOTE - These torques are recommended. Assembly tightening torque depends on many factors, including lubrication, coating and surface finishing. The manufacturer has to be consulted.

Dimensions and hydraulic circuit

Single acting version

Single function configuration with side P and T ports.

Hydraulic circuit

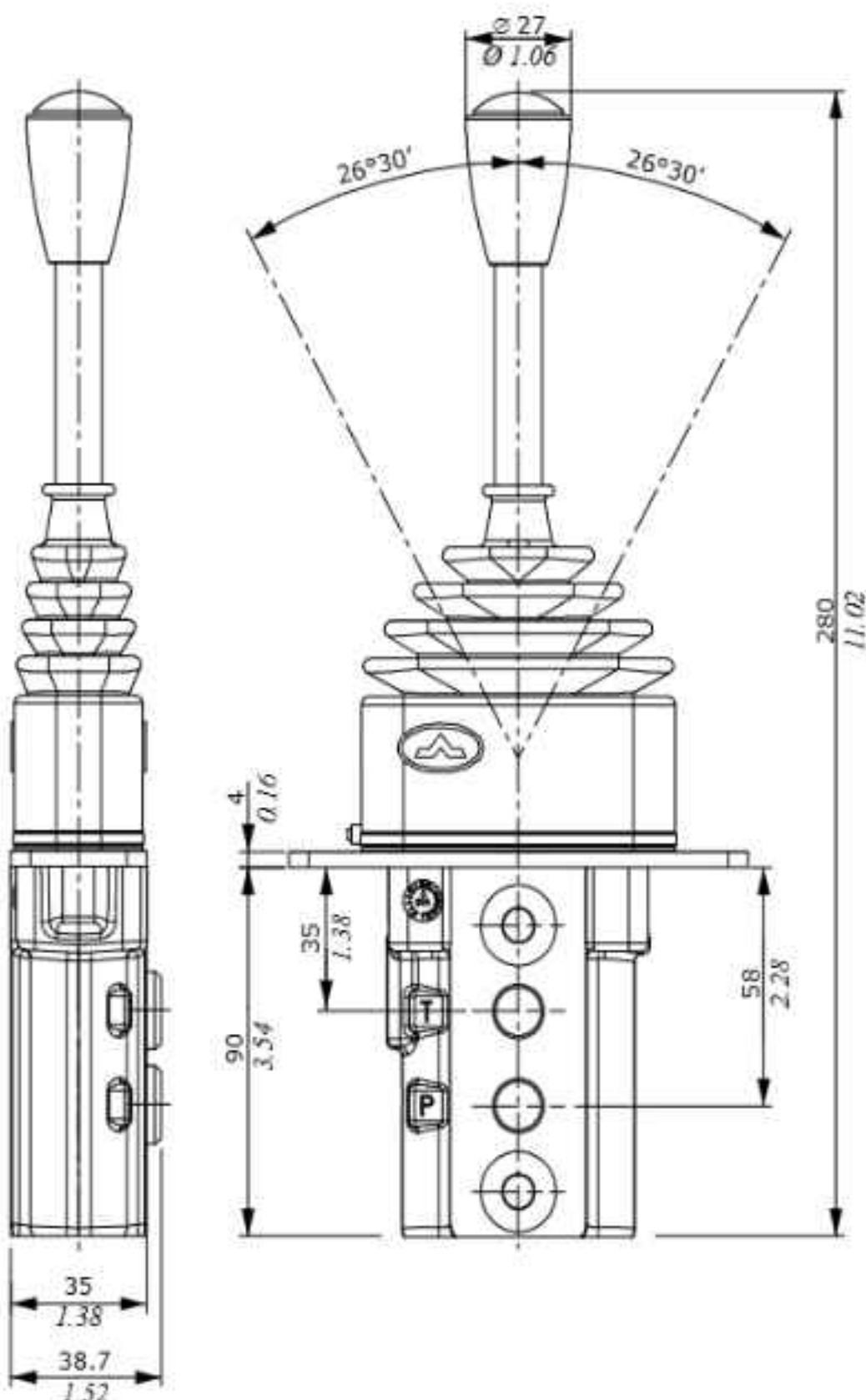
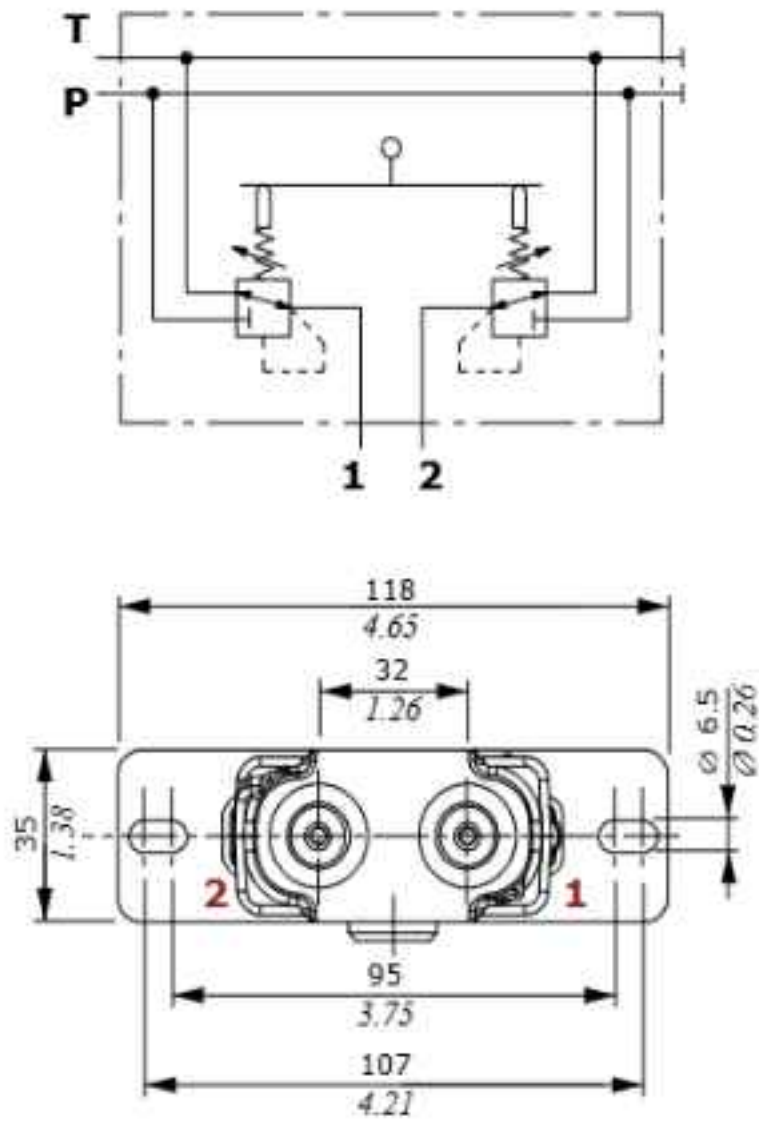

SVM100/n version

Multiple function configuration with side P and T ports.

Hydraulic circuit

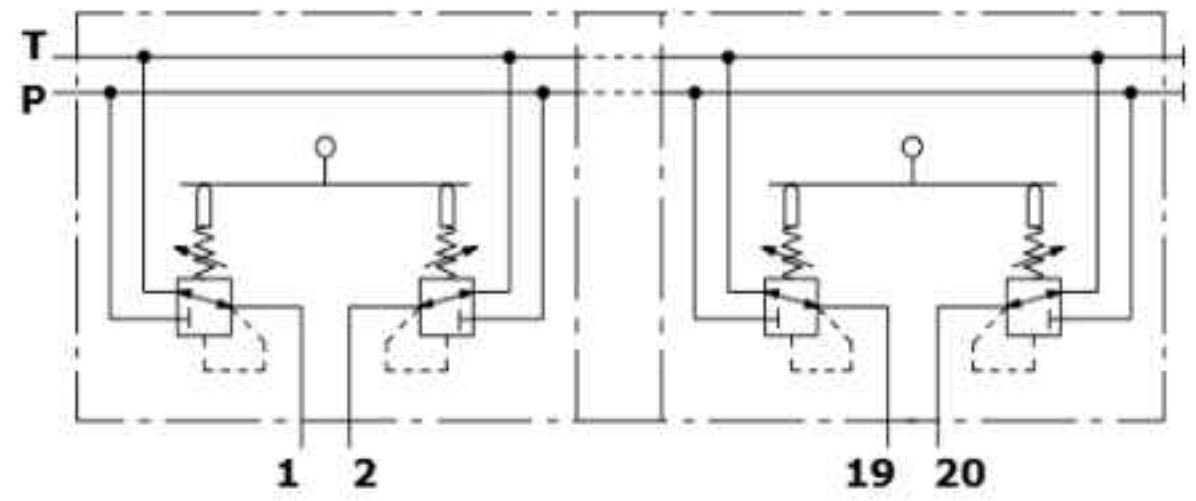

TYPE	E		F		TYPE	E		F	
	mm	in	mm	in		mm	in	mm	in
SVM100/2	70	2.76	75.2	2.96	SVM100/7	245	9.65	250.2	9.85
SVM100/3	105	4.13	110.2	4.34	SVM100/8	280	11.02	285.2	11.23
SVM100/4	140	5.51	145.2	5.72	SVM100/9	315	12.40	320.2	12.61
SVM100/5	175	6.89	180.2	7.09	SVM100/10	350	13.78	355.2	13.98
SVM100/6	210	8.27	215.2	8.27					

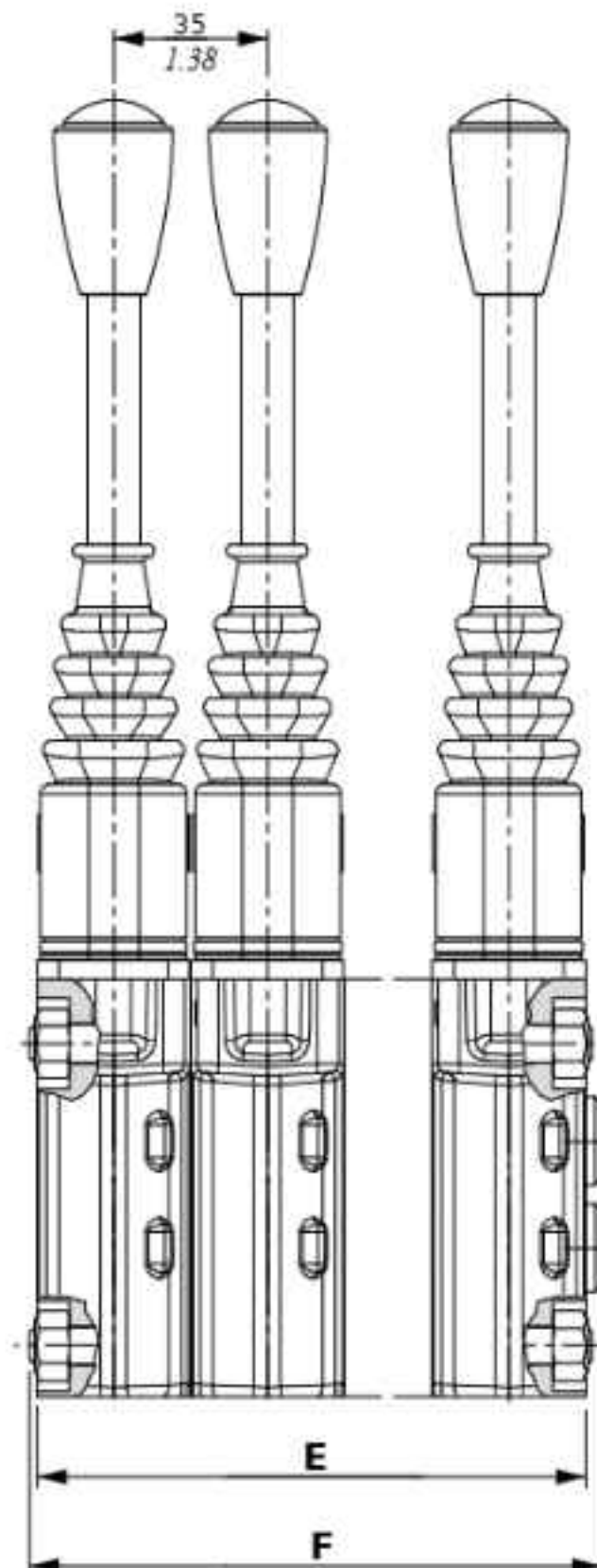

Dimensions and hydraulic circuit

SVM101 version

Single function configuration with bottom P and T ports.

Hydraulic circuit

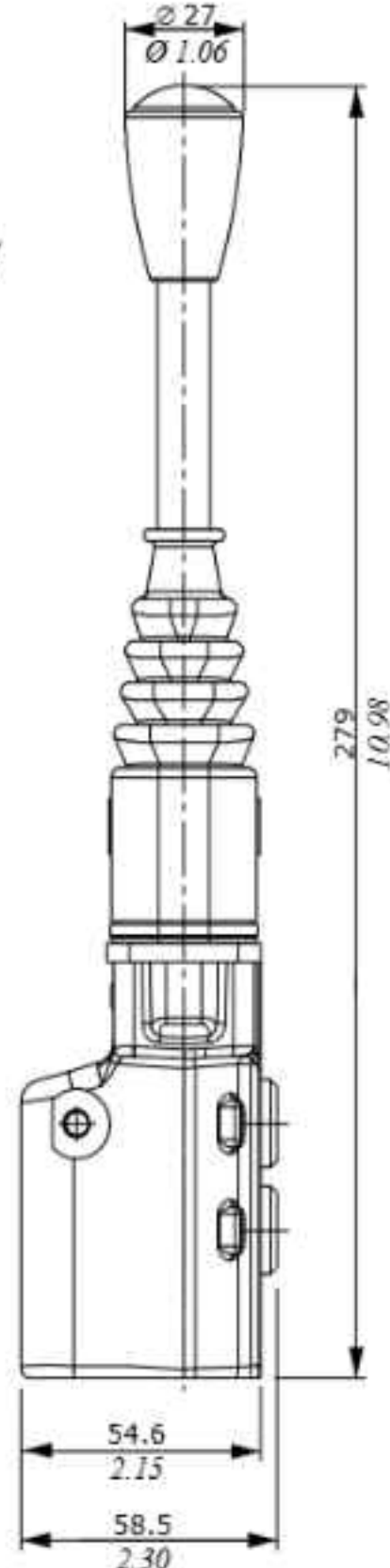
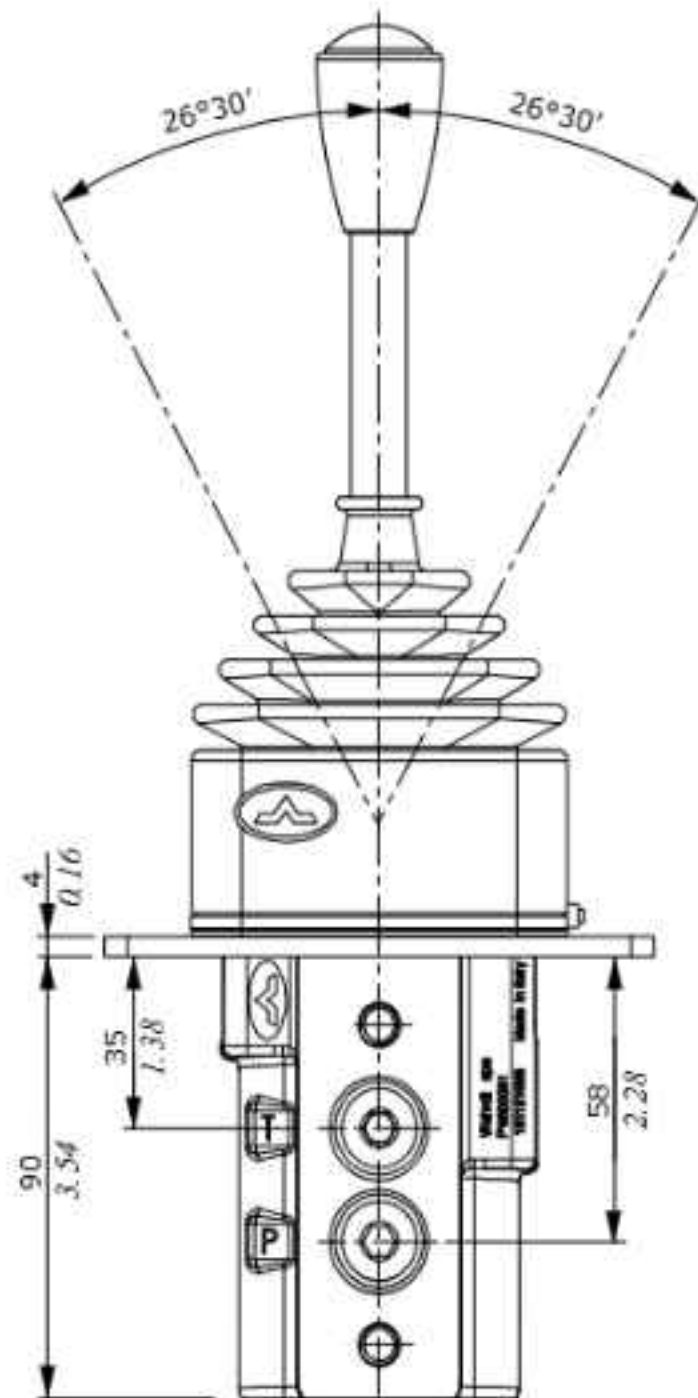
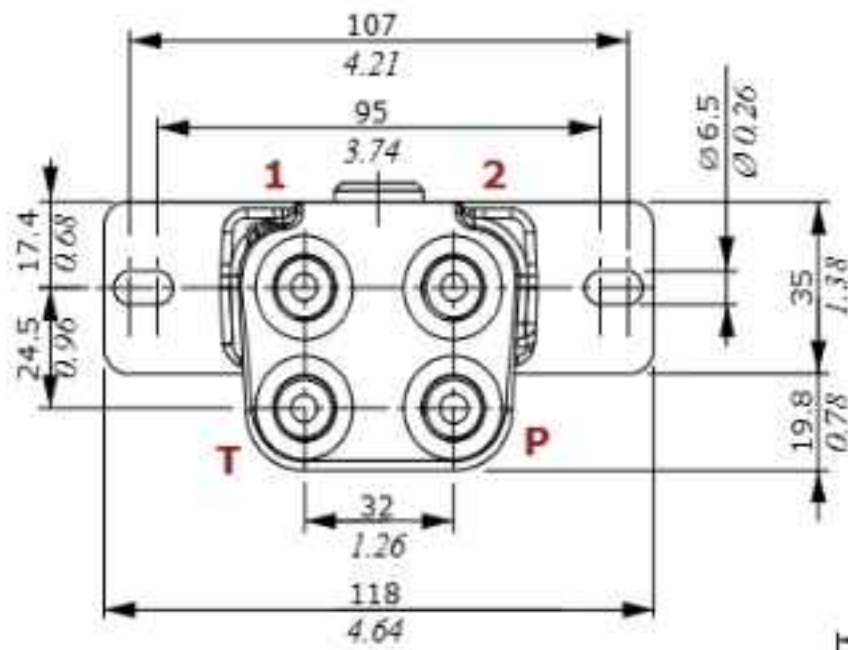
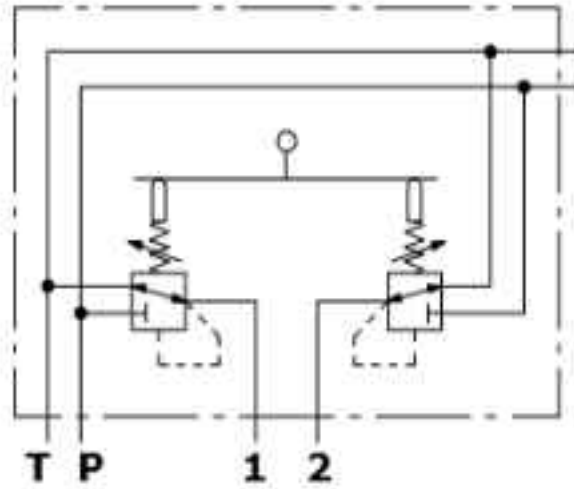

SVM101/n version

Multiple function configuration with bottom P and T ports.

Hydraulic circuit

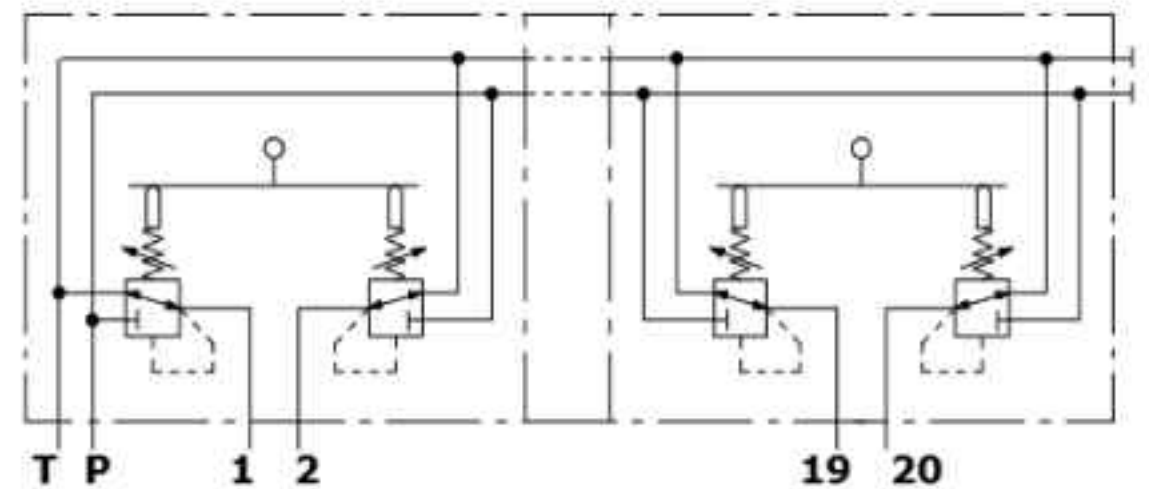

TYPE	E		F		TYPE	E		F	
	mm	in	mm	in		mm	in	mm	in
SVM101/2	89.6	3.53	93.3	3.67	SVM101/7	264.6	10.42	268.3	10.56
SVM101/3	124.6	4.91	128.3	5.05	SVM101/8	299.6	11.79	303.3	11.94
SVM101/4	159.6	6.28	163.3	6.43	SVM101/9	334.6	13.17	338.3	13.32
SVM101/5	194.6	7.66	198.3	7.81	SVM101/10	369.6	14.55	373.3	14.70
SVM101/6	229.6	9.04	233.3	9.18					

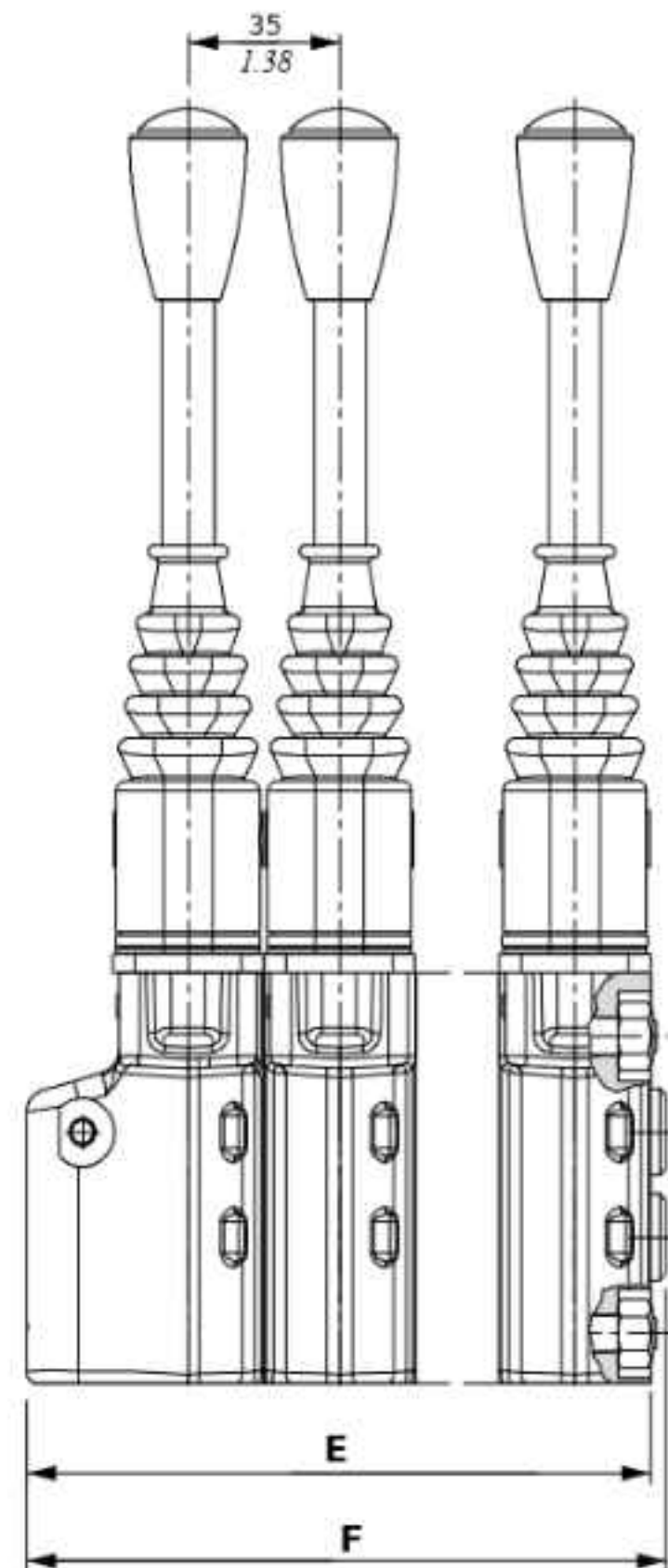

Ordering codes

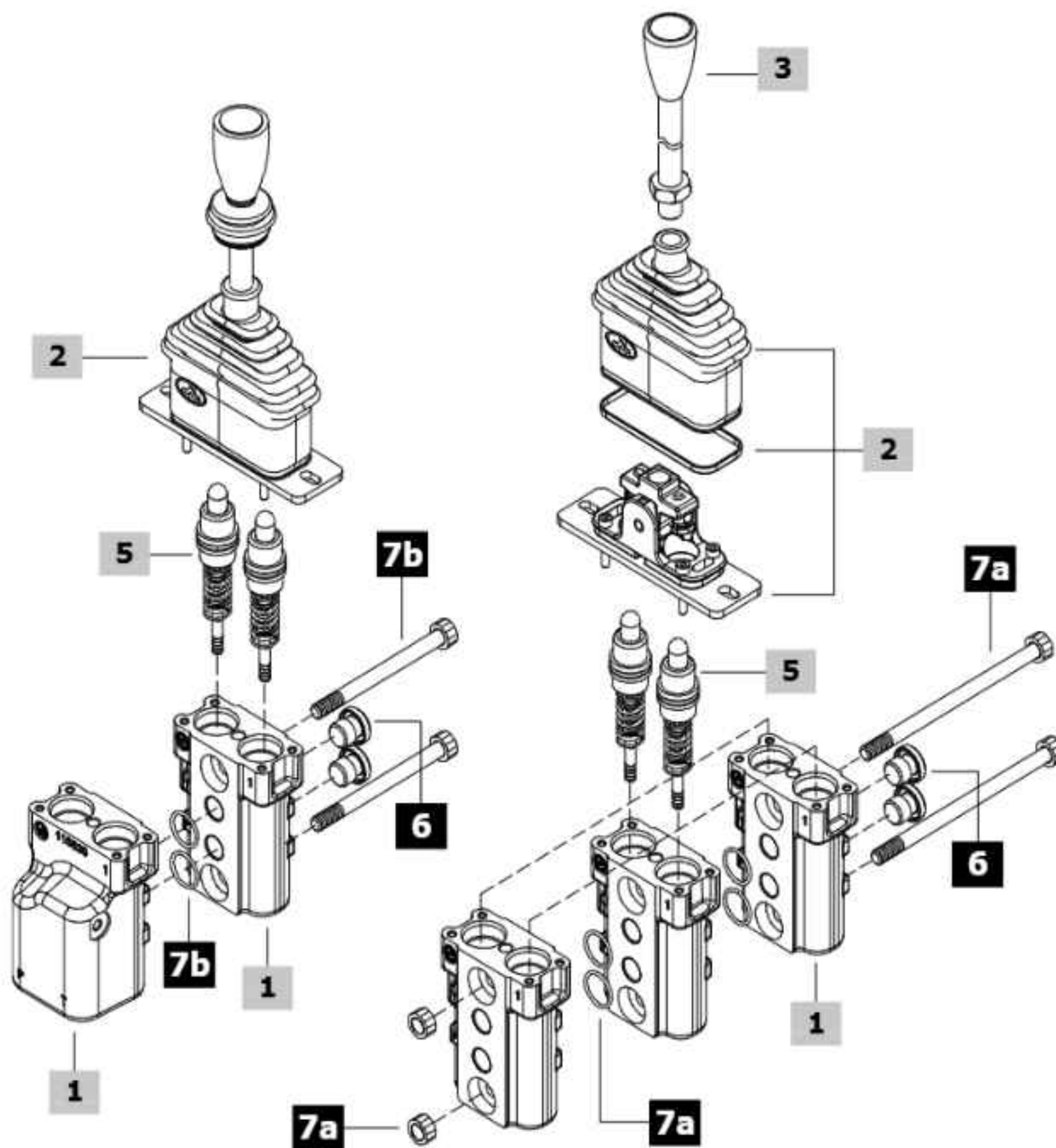
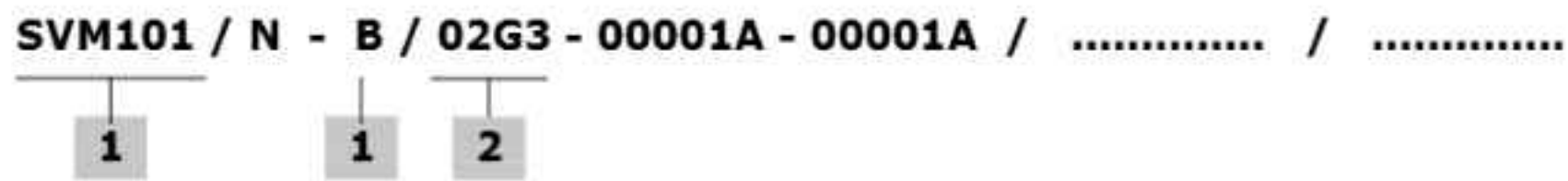
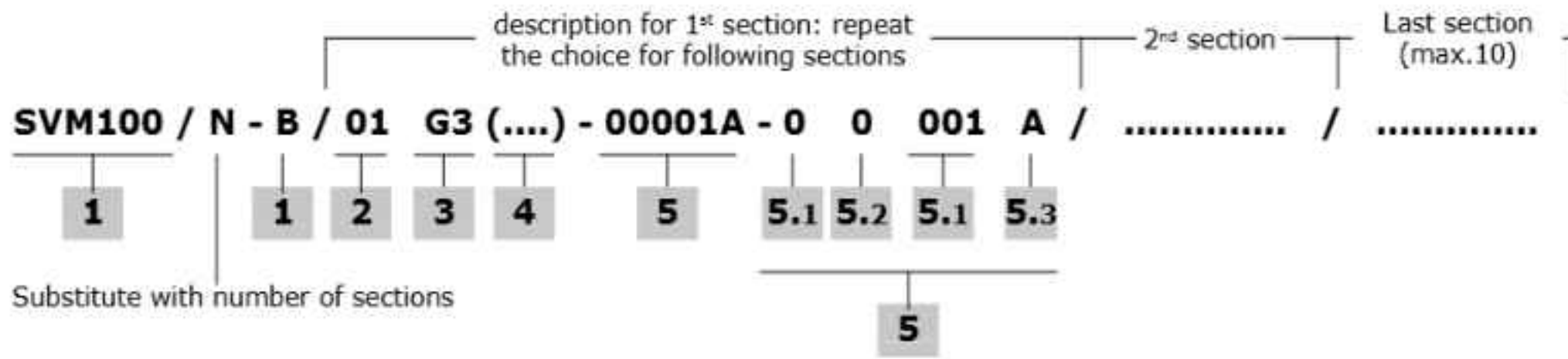

1 Body kit *

TYPE	CODE	DESCRIPTION
SVM100-B	3CO3122300	With side P and T ports
SVM101-B	3CO3122310	With bottom P and T ports

2 Control option

Complete with rubber bellow and fixing wrapper

Without handlever (for standard handlever see 3)

TYPE	CODE	DESCRIPTION
01	5CIN101000	Spring return to neutral position
03S	5CIN103008	With friction and neutral sensing, for 10, V, H, P and S series handles
05	5CIN105000	With detent in pos. 1 and spring return in neutral position
06	5CIN106000	With detent in pos. 2 and spring return in neutral position
07	5CIN107000	With detent in pos. 1 and 2; spring return in neutral position

Controls with handlevers

For assembling reasons, the under listed control kits must be supplied complete with handle. Please contact our Sales Department for use with different handles.

TYPE	CODE	DESCRIPTION
02G3	5CIN102000	With detent in neutral position, spring return in neutral position and type G knob; can not be used on two adjacent sections
03G3	5CIN103000	With friction and neutral sensing, G knob
03E3	5CIN103005	As previous one, E knob, 15° bending rod
03JL3	5CIN103004	As previous one, JL knob
10G3	5CIN110000	With friction and detent in neutral position, G knob; can not be used on two adjacent sections
11G3	5CIN111000	Detent in 3 positions, G knob; can not be used on two adjacent sections
16G3	5CIN116000	With (NO) microswitch operation in either directions, neutral sensing, spring return in neutral position, G knob
16TM3G3	5CIN116005	With (NC) microswitch operation in either directions, spring return in neutral position, G knob, Heavy Duty configuration
16TM1G3	5CIN116004	As 16TM3G3, microswitch operation with lever towards port 1
16TM2G3	5CIN116004	As 16TM3G3, microswitch operation with lever towards port 2
20G3	5CIN120000	Detent in position 1 and 2, friction, neutral sensing, G knob
22G3	5CIN122000	With (NO) microswitch operation in either directions, friction, G knob

3 Standard handlevers**Without microswitch:**

TYPE	CODE	DESCRIPTION
G3	5AST271218G	Ogival with portlight, straight rod (STANDARD)
G3(15)	5AST371227G	Ogival with portlight, 15° sloping rod
G3(30)	5AST371228G	Ogival with portlight, 30° sloping rod
E	5AST371215E	Spherical with portlight, 15° sloping rod

With microswitch: Not available with control type 07-16-20-22

CAUTION: for assembly requirements these handlevers, if ordered as a spare parts, will be supplied complete with rubber bellow

TYPE	CODE	DESCRIPTION
JJ3	5AST271218J	With spring return
JM3	5AST271218M	With detent rocker switch

For J handle specifications see the "handles and handlevers" catalogue

4 Handle position**Only for sloping rod**

TYPE	DESCRIPTION
(0)	Handlever oriented towards plugged P and T ports
(90)	Handlever oriented towards port 1
(180)	Handlever oriented towards open P and T ports
(270)	Handlever oriented towards port 2

5 Pressure control curves

For list available see from page 27

5.1 Curve type

TYPE	DESCRIPTION
0	Standard

5.2 Typology of curves

TYPE	DESCRIPTION
0	With step
1	Without step
2	Piecewise with step
3	Piecewise without step

5.3 Curve identification

Progressive number

5.4 Return springs

TYPE	DESCRIPTION
M	Operation range from 18 to 25.5 N - <i>from 4.04 to 5.73 lbf</i>
A	Operation range from 23 to 35.2 N - <i>from 5.17 to 7.91 lbf</i>
B	Operation range from 23 to 68.1 N - <i>from 5.17 to 15.31 lbf</i>
C	Operation range from 89 to 176 N - <i>from 20 to 39.56 lbf</i>
D	Operation range from 110 to 220 N - <i>from 24.73 to 49.46 lbf</i>
E	Operation range from 137.8 to 276.1 N - <i>from 31 to 62.07 lbf</i>

6 Closing plugs *

CODE	DESCRIPTION
3XTAP719150	G1/4 plug for rear ports (n. 2 plugs)

7b Assembling kit for SVM100

Only for SVM100/2 or higher: this kit contains tie rods, nuts and O-ring seal.

CODE	DESCRIPTION	CODE	DESCRIPTION
5TIR108073	For SVM100/2	5TIR108248	For SVM100/7
5TIR108108	For SVM100/3	5TIR108283	For SVM100/8
5TIR108143	For SVM100/4	5TIR108319	For SVM100/9
5TIR108178	For SVM100/5	5TIR108353	For SVM100/10
5TIR108213	For SVM100/6		

7b Assembling kit for SVM101

Only for SVM101/2 or higher: this kit contains tie rods, nuts and O-ring seal.

CODE	DESCRIPTION	CODE	DESCRIPTION
5TIR108050	For SVM101/2	5TIR108225	For SVM101/7
5TIR108085	For SVM101/3	5TIR108261	For SVM101/8
5TIR108122	For SVM101/4	5TIR108295	For SVM101/9
5TIR108156	For SVM101/5	5TIR108330	For SVM101/10
5TIR108190	For SVM101/6		

NOTE (*) - Codes are referred to **BSP** thread.

Configuration option

Controls without handlevers

Controls type

01: Spring return to neutral position

05: With detent in position 1 and spring return in neutral position

06: With detent in position 2 and spring return in neutral position

07: With detent in positions 1 and 2; spring return in neutral position

03S: With friction and neutral sensing, arranged for handles with M14x1.5 thread (see the "handles and handlevers" catalogue)

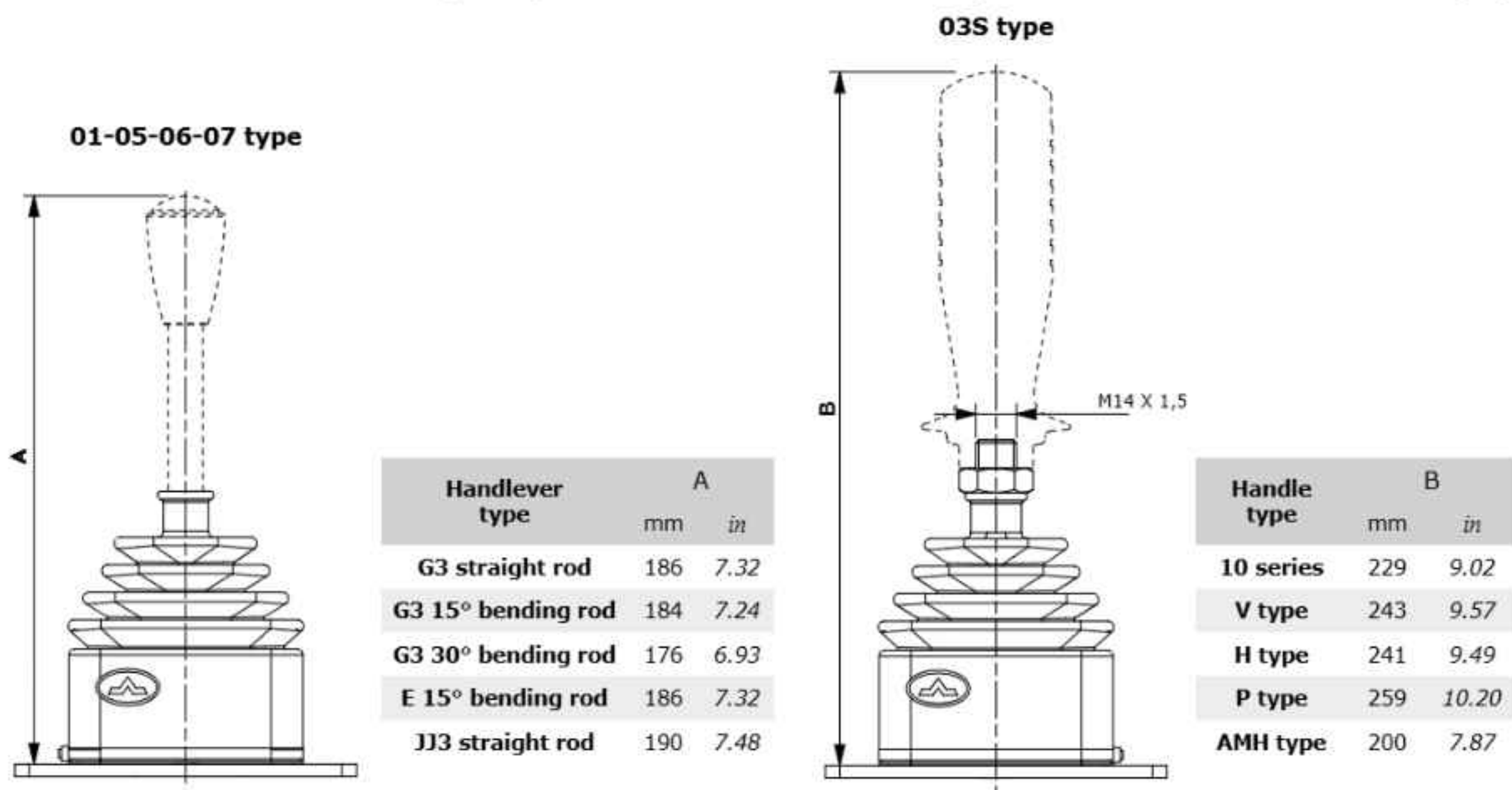

Handlevers

Without microswitch

G type: Ogival knob with customizable portlight. It's possible to insert labels with specific machine functions (for example: lifting function): please contact our Sales Department.

E type: Spherical handle customizable as G type.

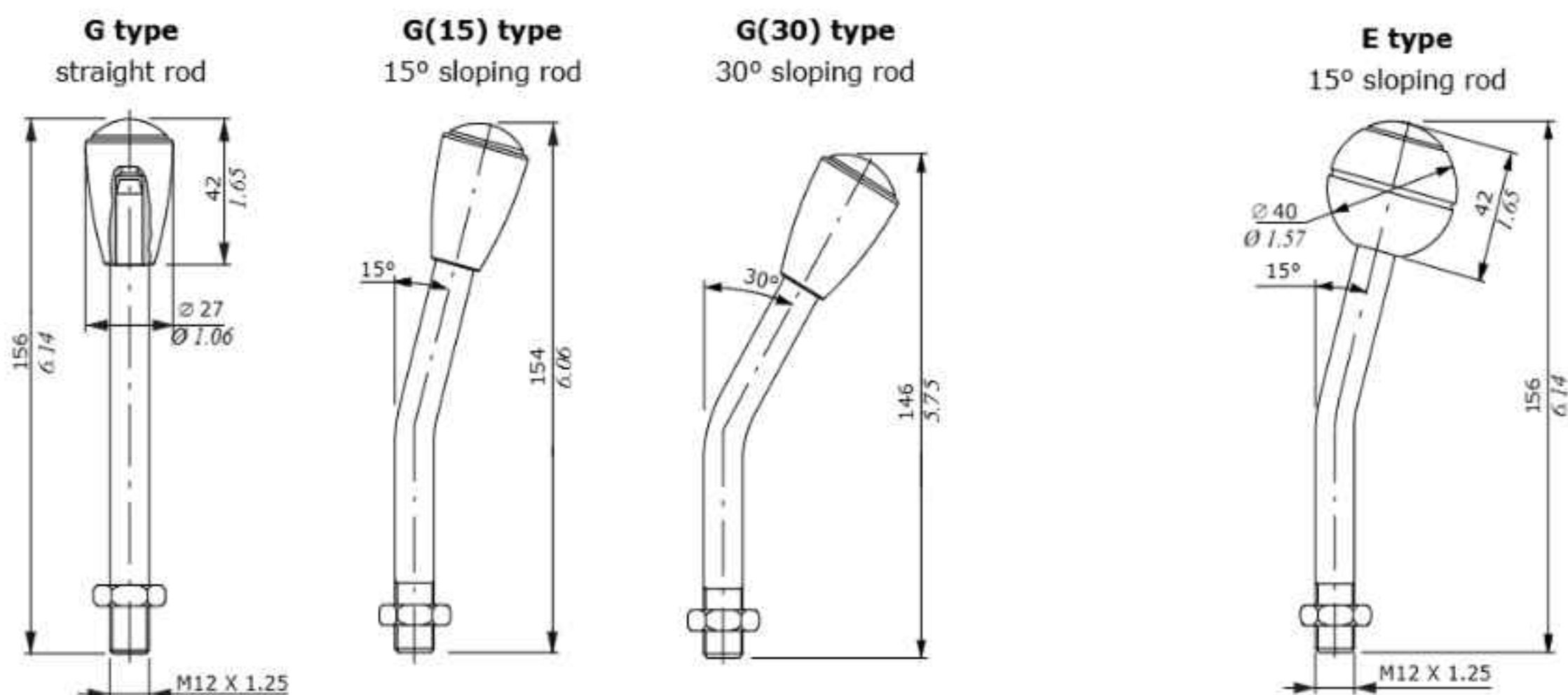

Handlevers

With microswitch

JM type: Ogival knob, small dimensions, available with detent rocker microswitch.

JJ type: As previous one, available with spring return push-button microswitch.

For technical features see catalogue D1WWEH01I.

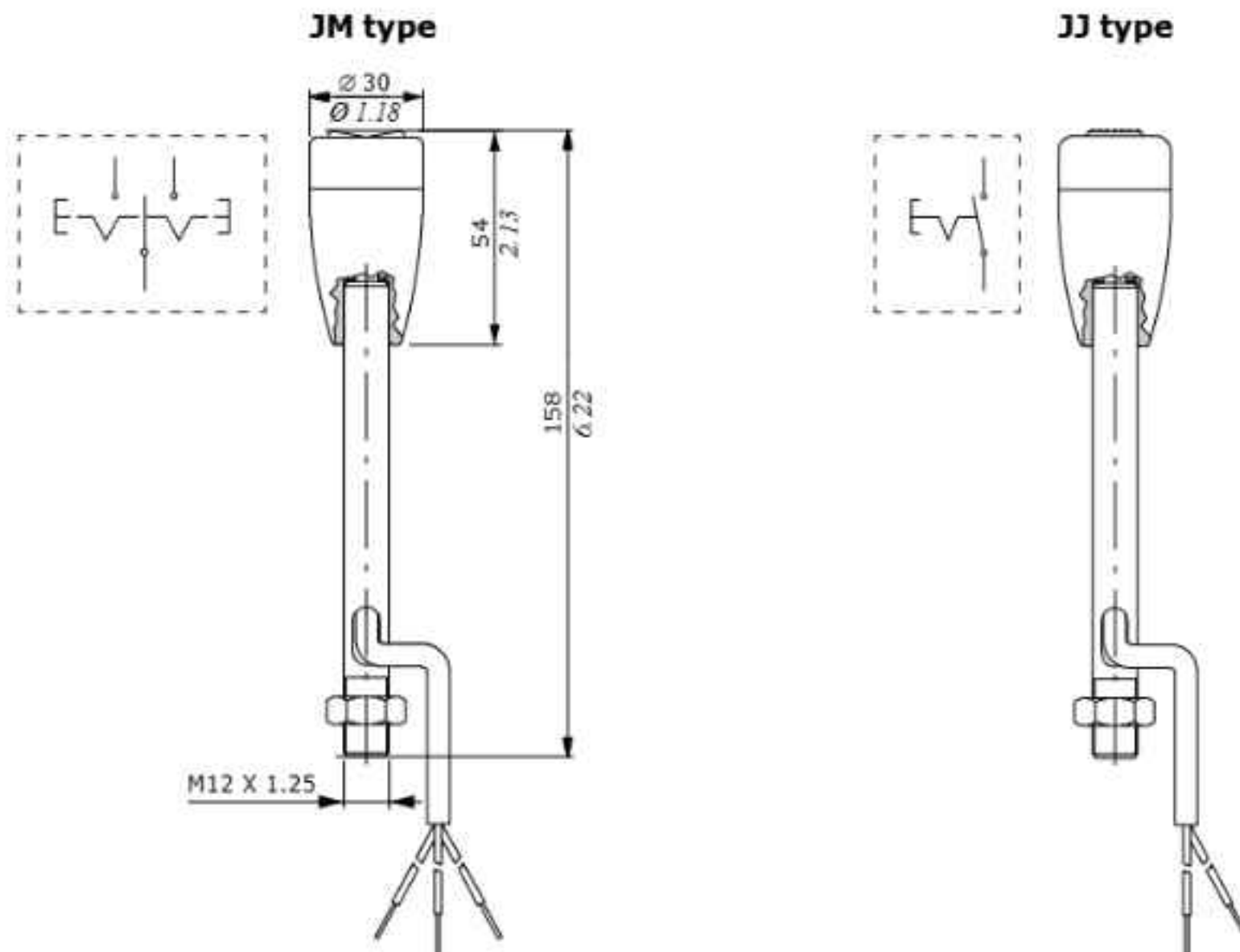

Mounting and orientation examples

G type
on 3 sections
pilot control valve

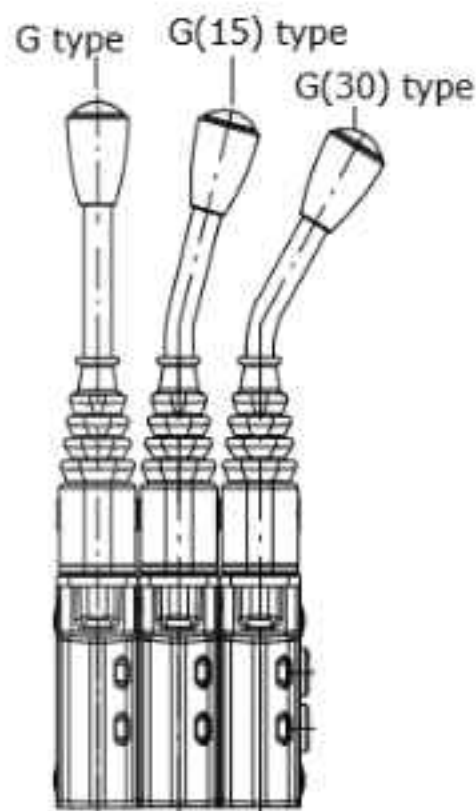

E type
on 2 sections
pilot control valve

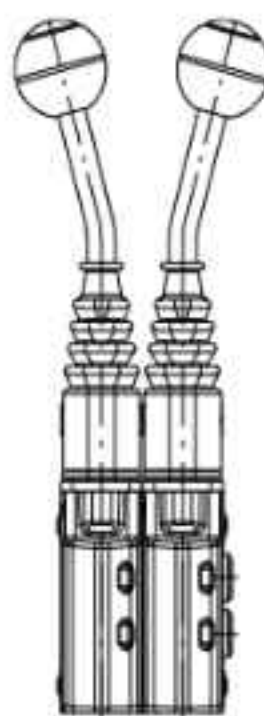

Sloping rod position

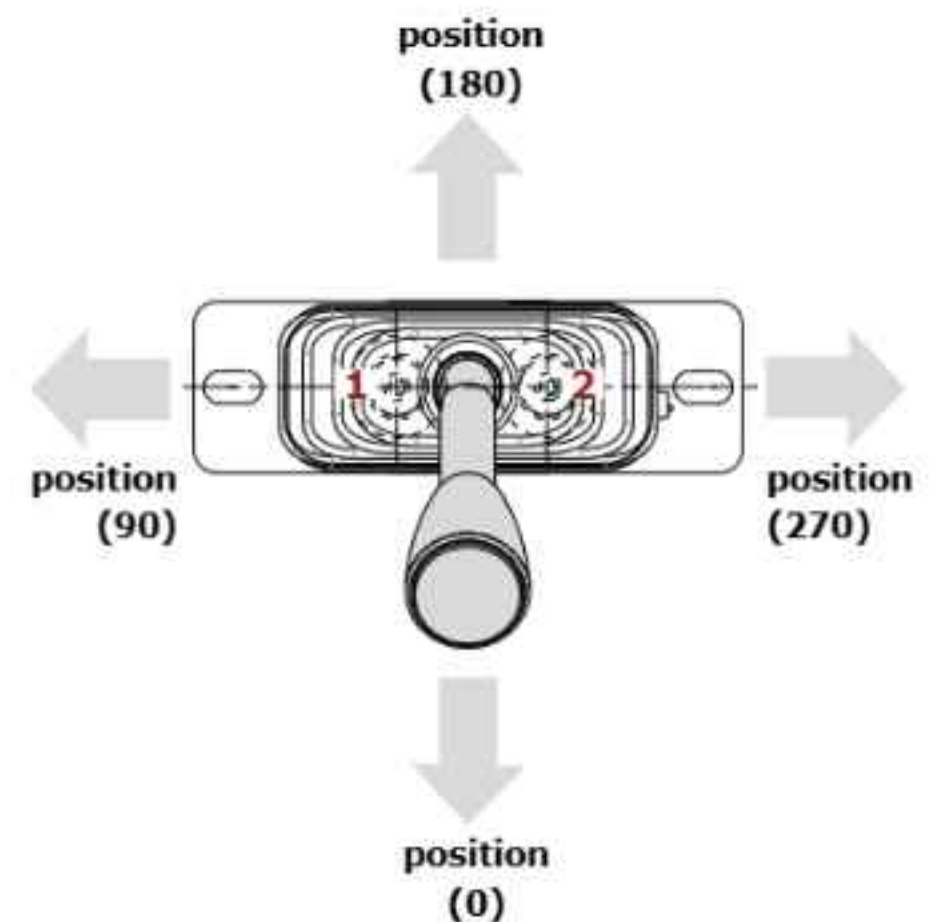

Configuration option

Controls with levers

Without microswitch

02G3: With detent in neutral position; it can not be used on two adjacent sections.

03G3: With friction: stop in any positions and neutral sensing. Ogival with portlight G type knob.

03E3: As type 03G3 control, E knob and 15° bending rod.

03JL3: As type 03G3 control, JL knob with spring return microswitch push-button.

10G3: With friction and detent in neutral position; it can not be used on two adjacent sections.

11G3: Detent in neutral position, 1 and 2; it can not be use in adjacent sections.

20G3: With friction, stop in any positions and neutral sensing, with detent in positions 1 and 2.

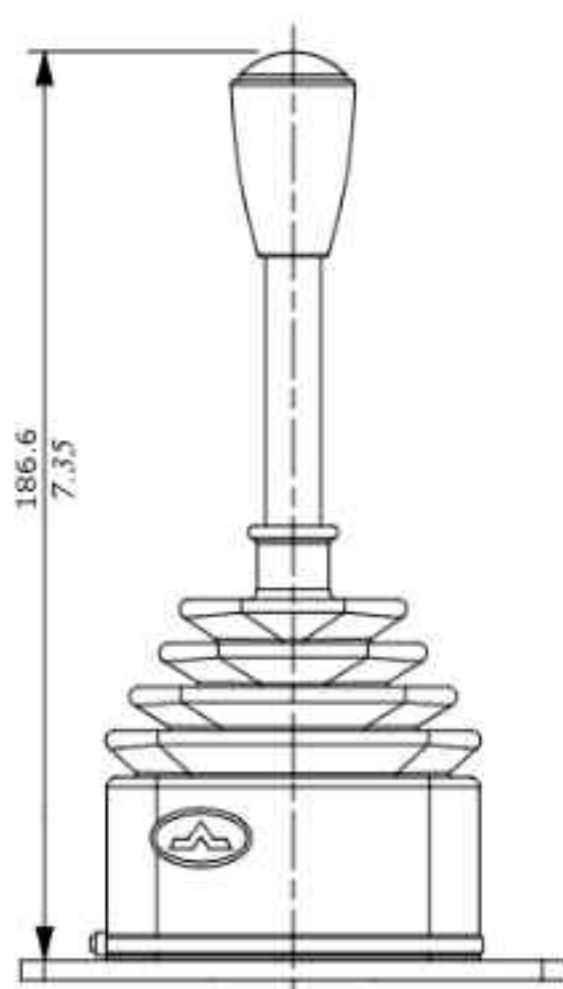
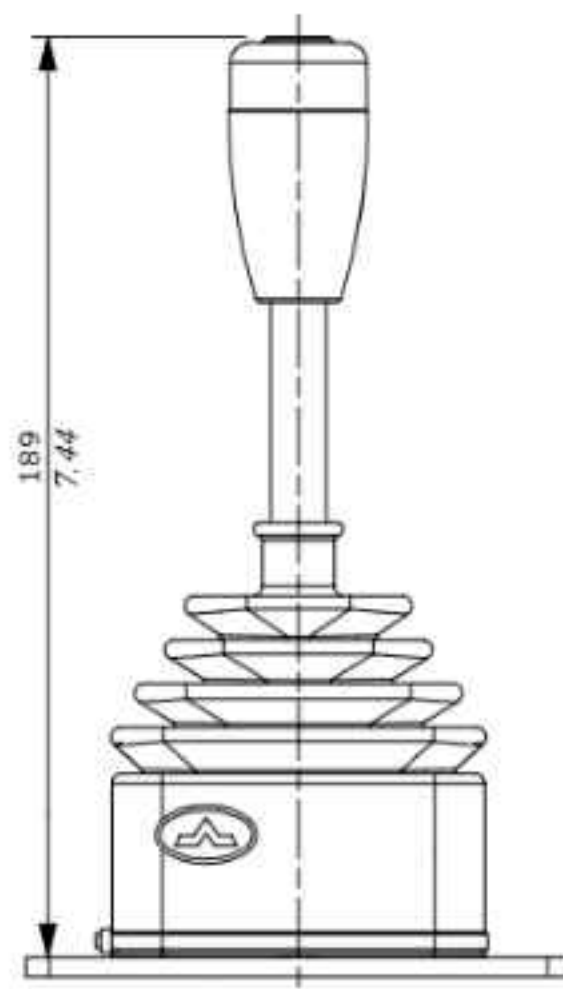
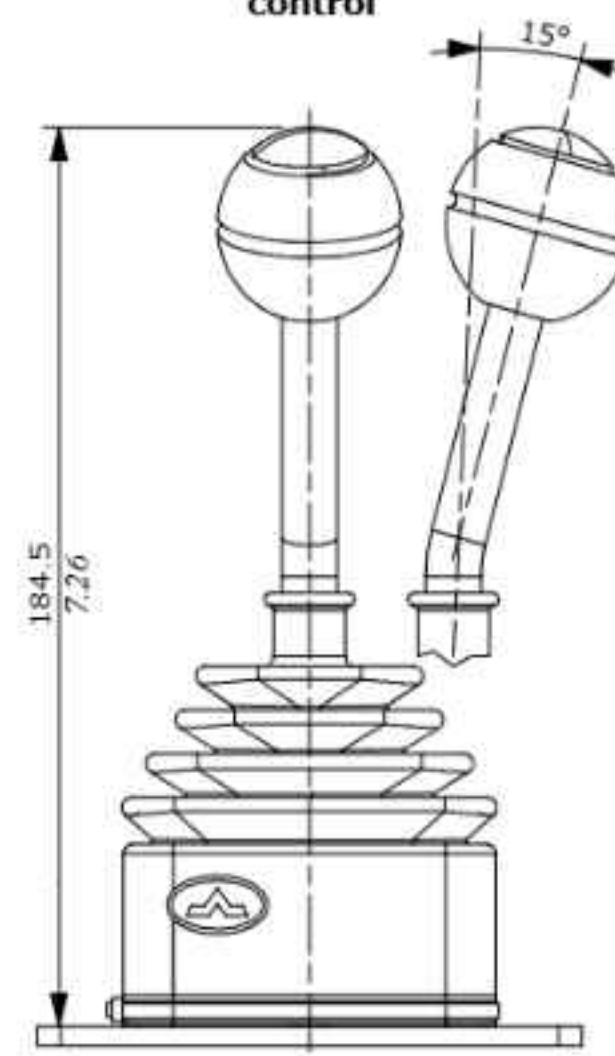
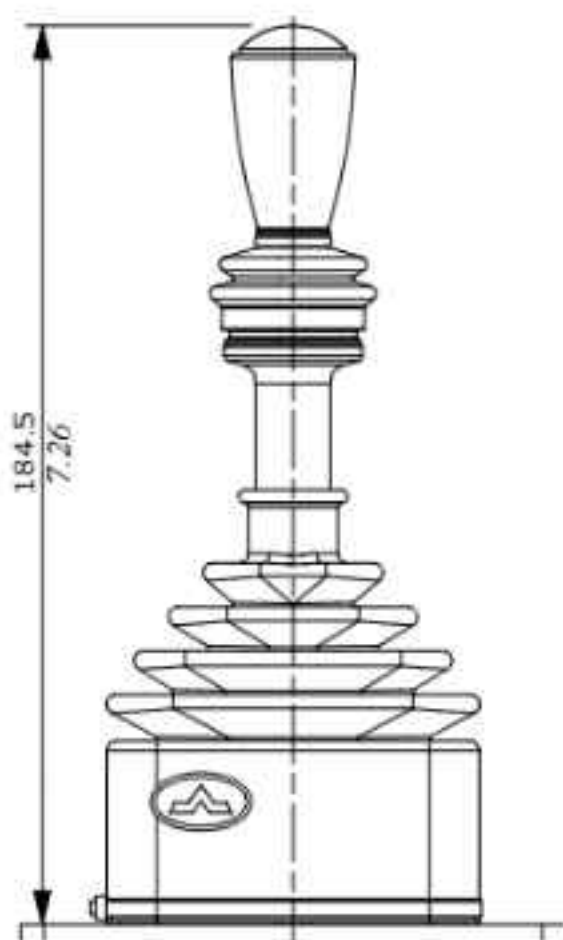
03G3-20G3
control03JL3
control03E3
control02G3-10G3-11G3
control

Controls with handlevers**Controls with microswitch**

16G3(NO): With (NO) microswitch operation in either directions, neutral sensing, spring return in neutral position.

16TM3G3(NC): With (NC) microswitch operation in either directions, protective shell and dust-proof seals

16TM1G3(NC): With (NC) microswitch operation towards port 1, protective shell and dust-proof seals

16TM2G3(NC): With (NC) microswitch operation towards port 2, protective shell and dust-proof seals

22G3(NO): With (NO) microswitch operation in either directions and friction (stop in any position)

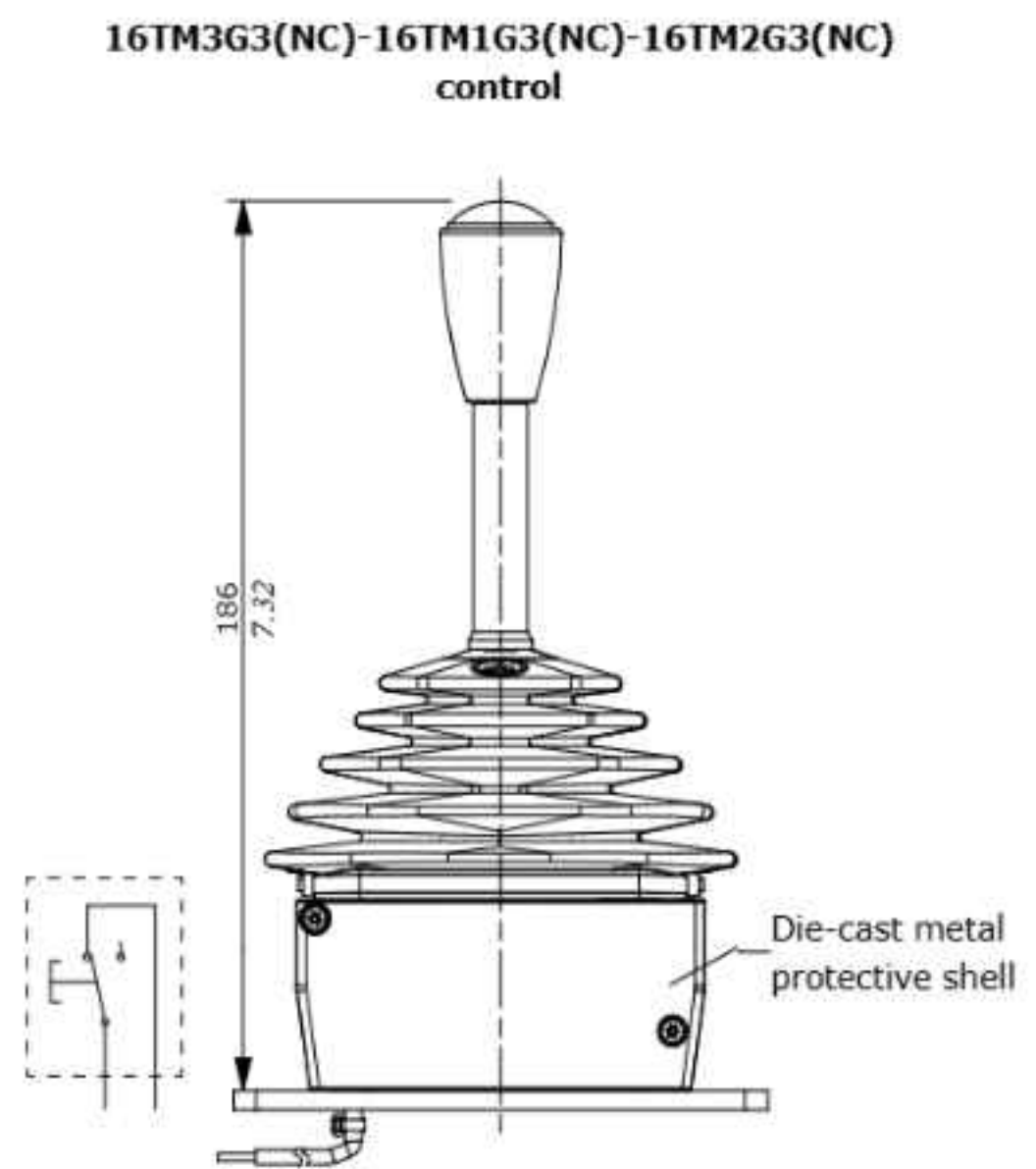
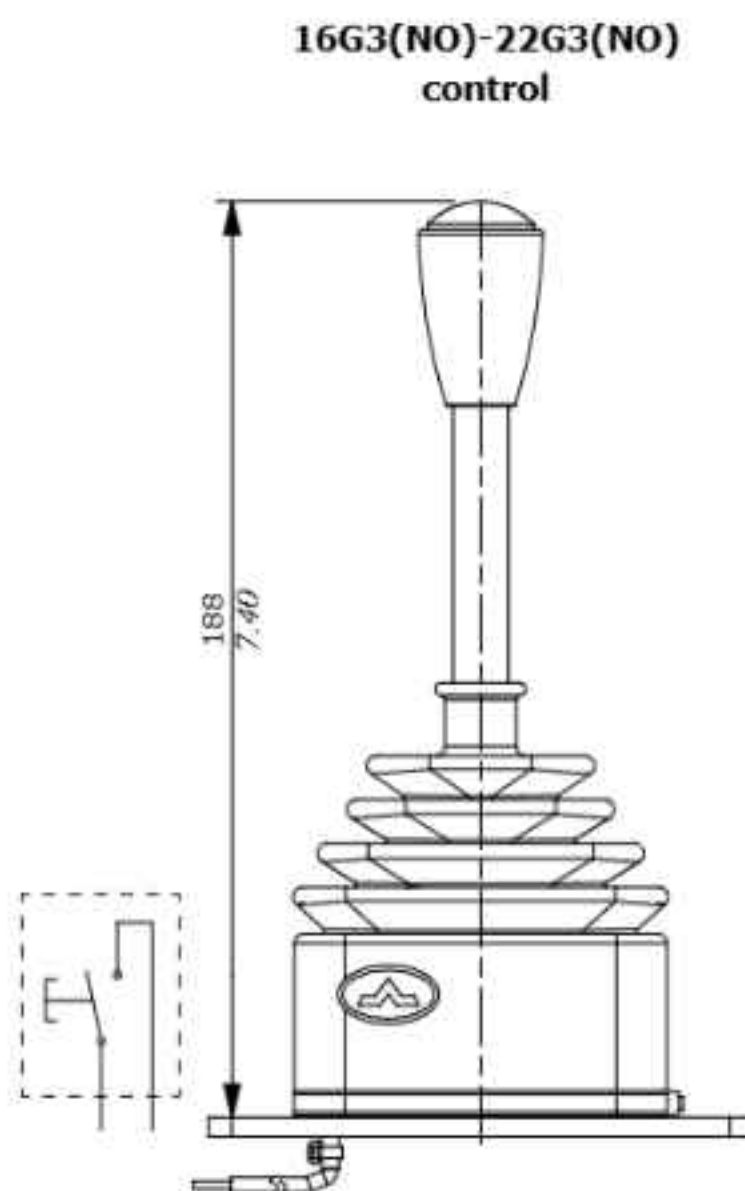

Dimensions and hydraulic circuit

SVM400

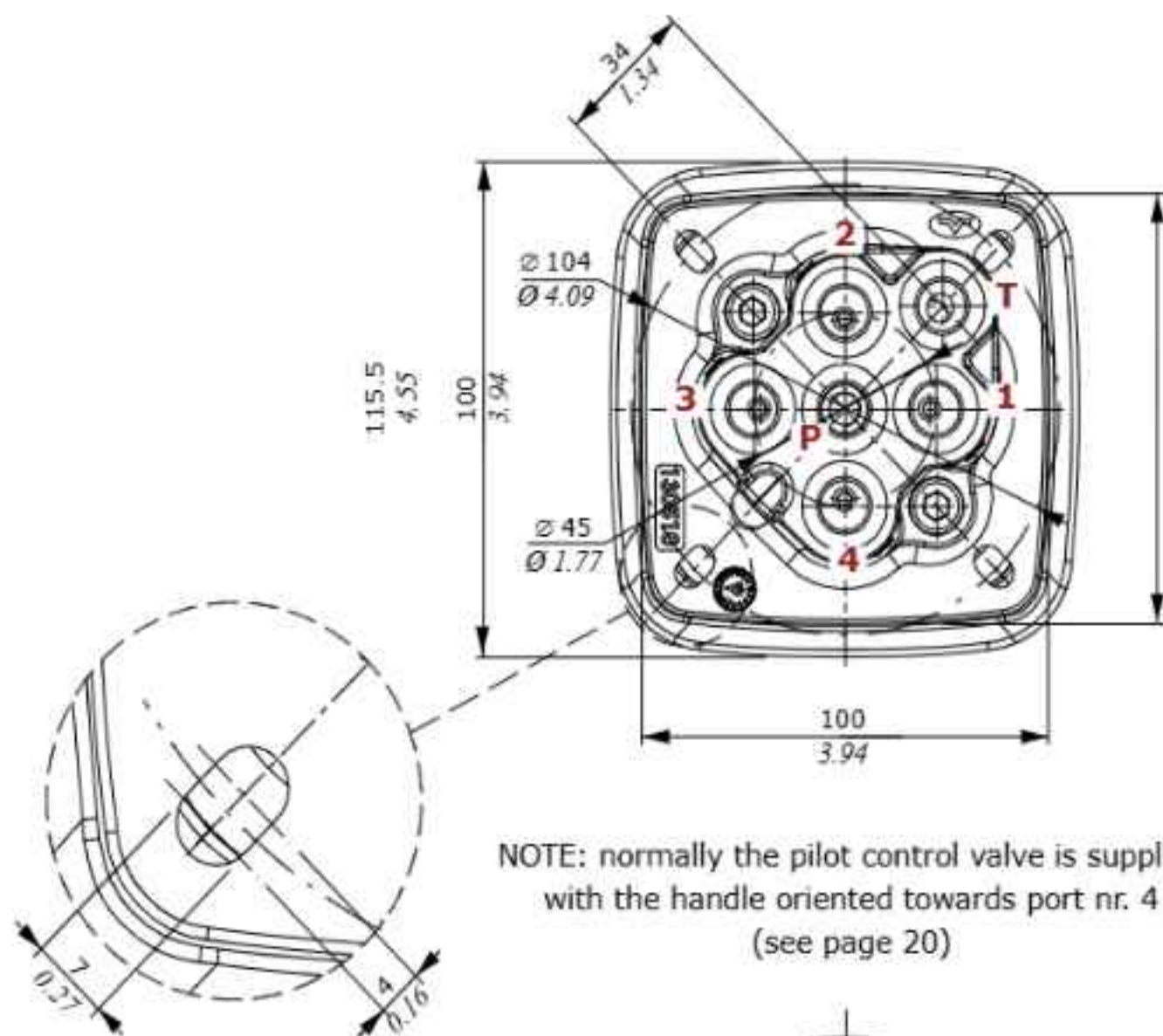

Configuration with one open ring

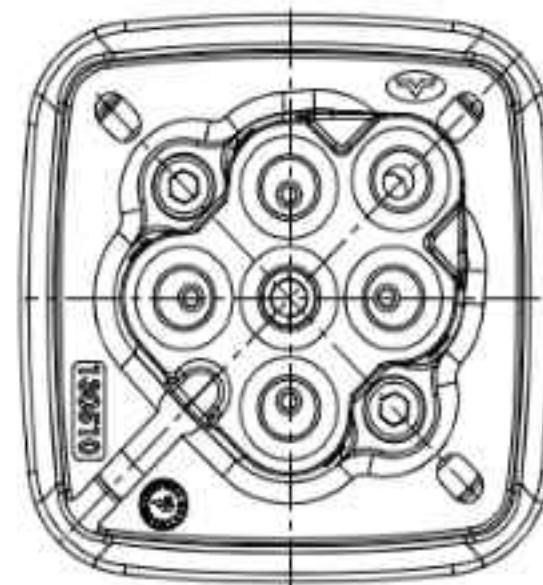

NOTE: normally the pilot control valve is supplied with the handle oriented towards port nr. 4 (see page 20)

Hydraulic circuit

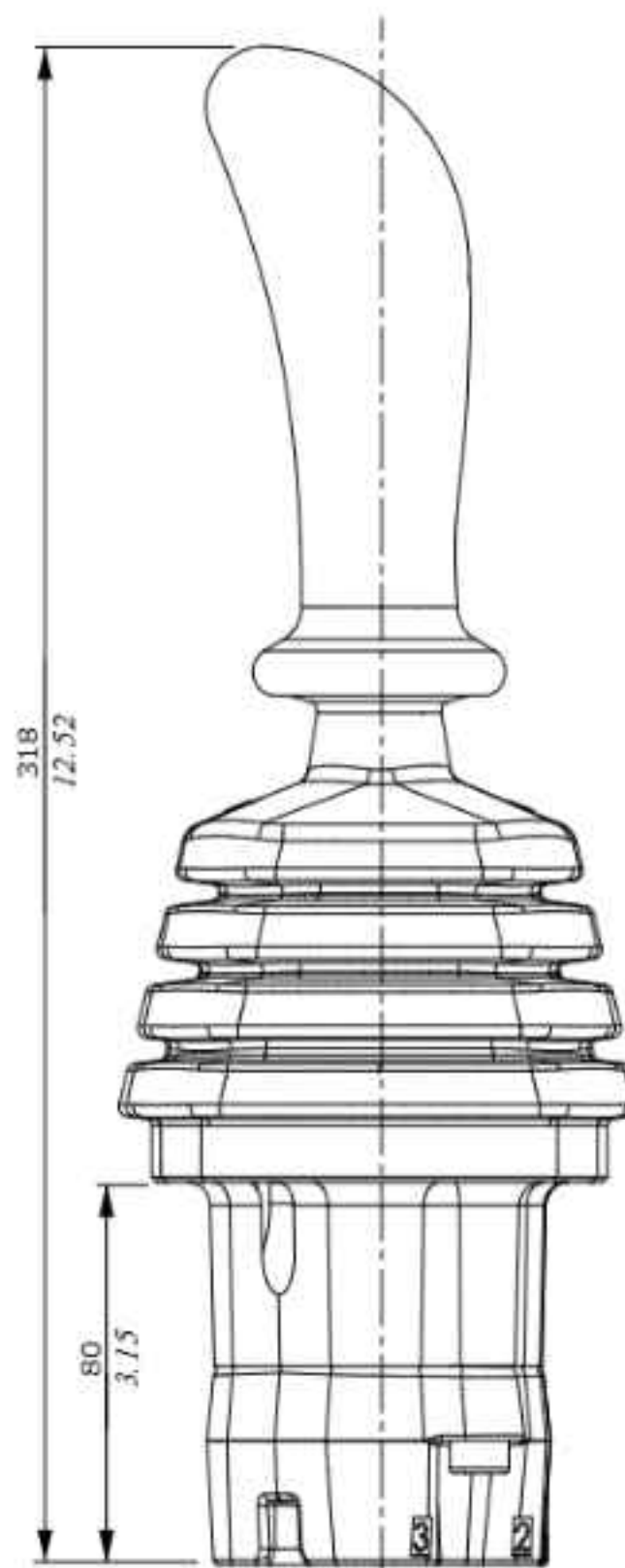
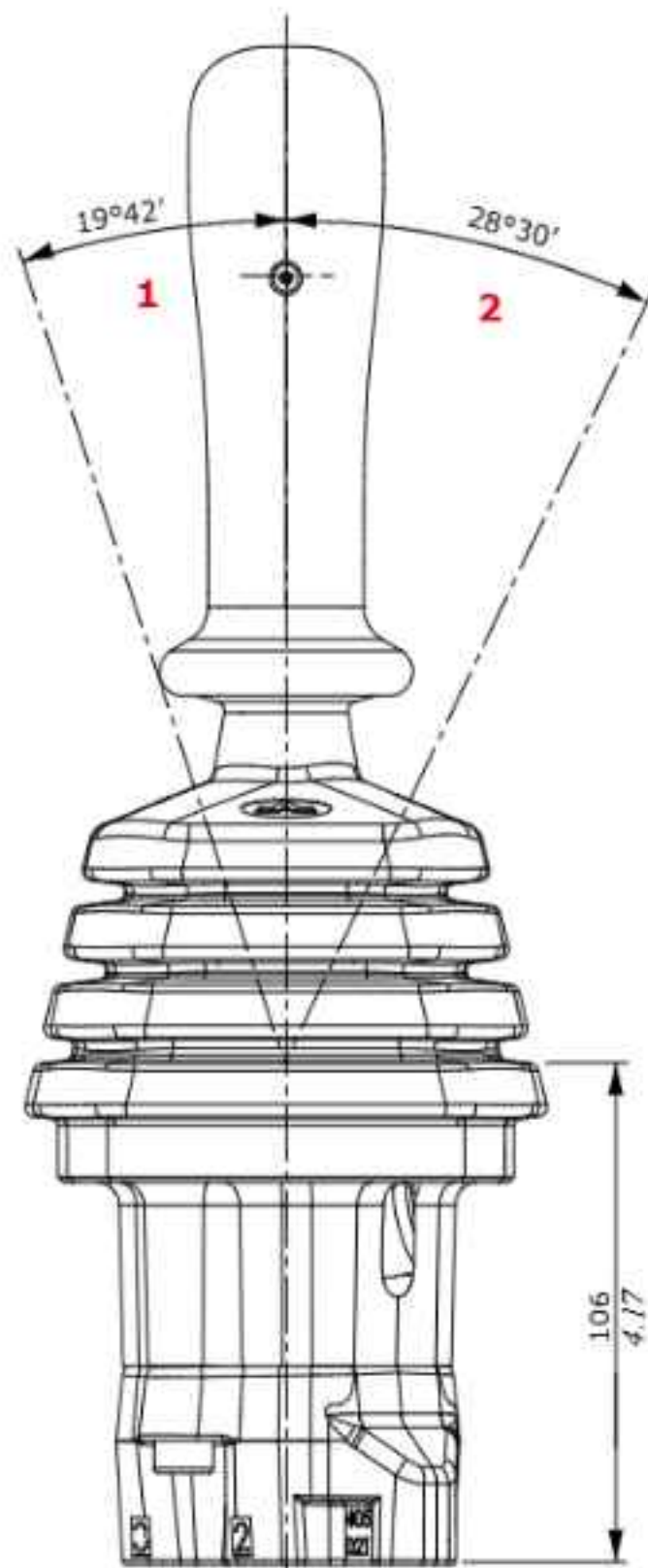
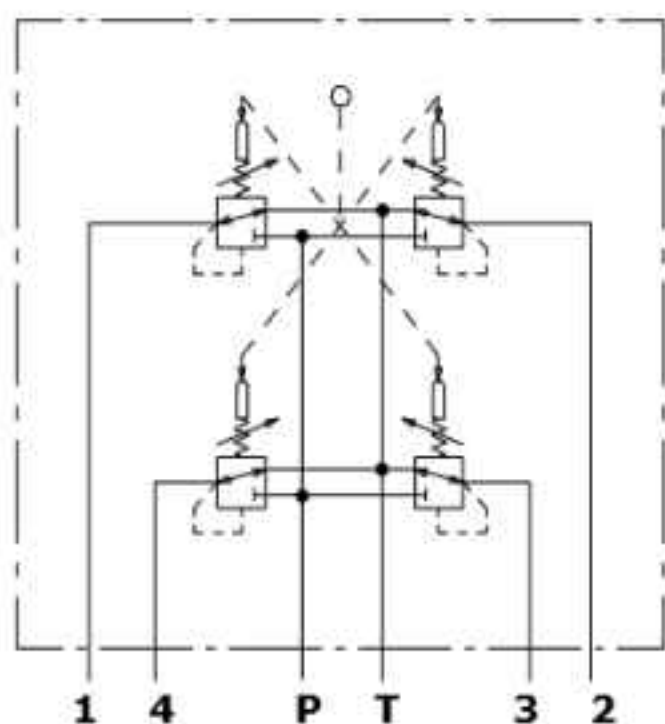

1 : Single work port
2 : Two simultaneous work ports

Dimensions and hydraulic circuit

SVM430

It's configured with pressure gauges (5) to get an additional output signal (ex. back-up alarm).

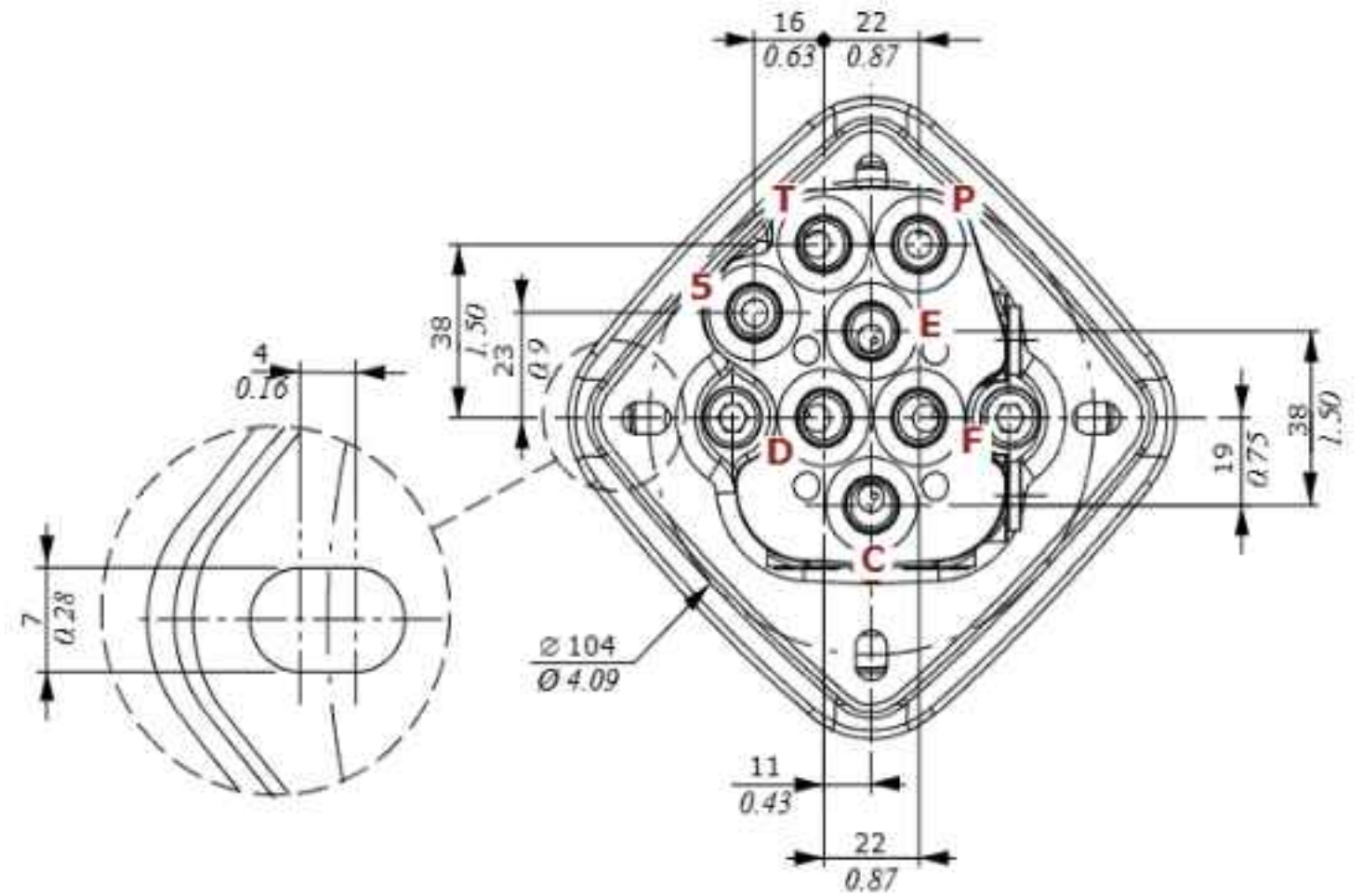

Hydraulic circuit

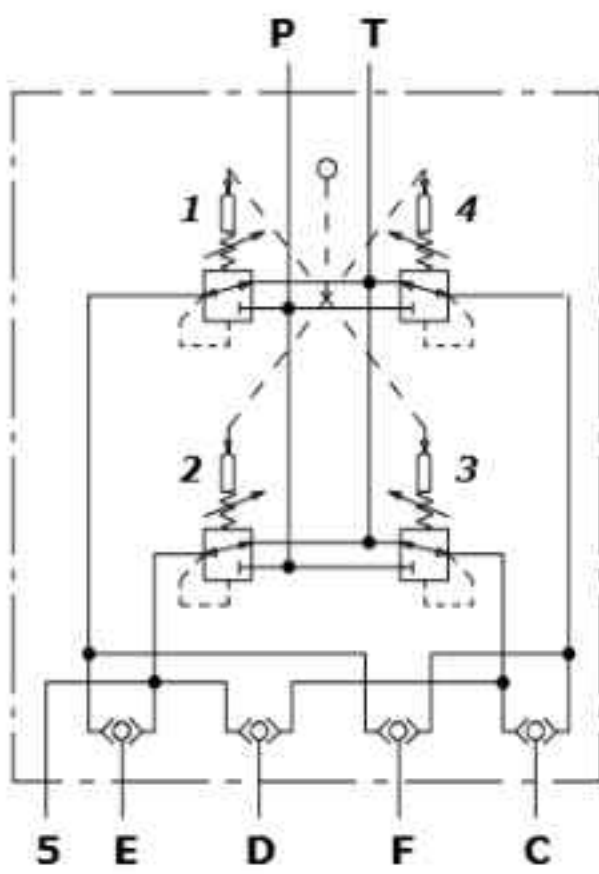

Work port 1 ⇒ EF port ⇒ right
 Work port 2 ⇒ ED port ⇒ back
 Work port 3 ⇒ CD port ⇒ left
 Work port 4 ⇒ CF port ⇒ forward

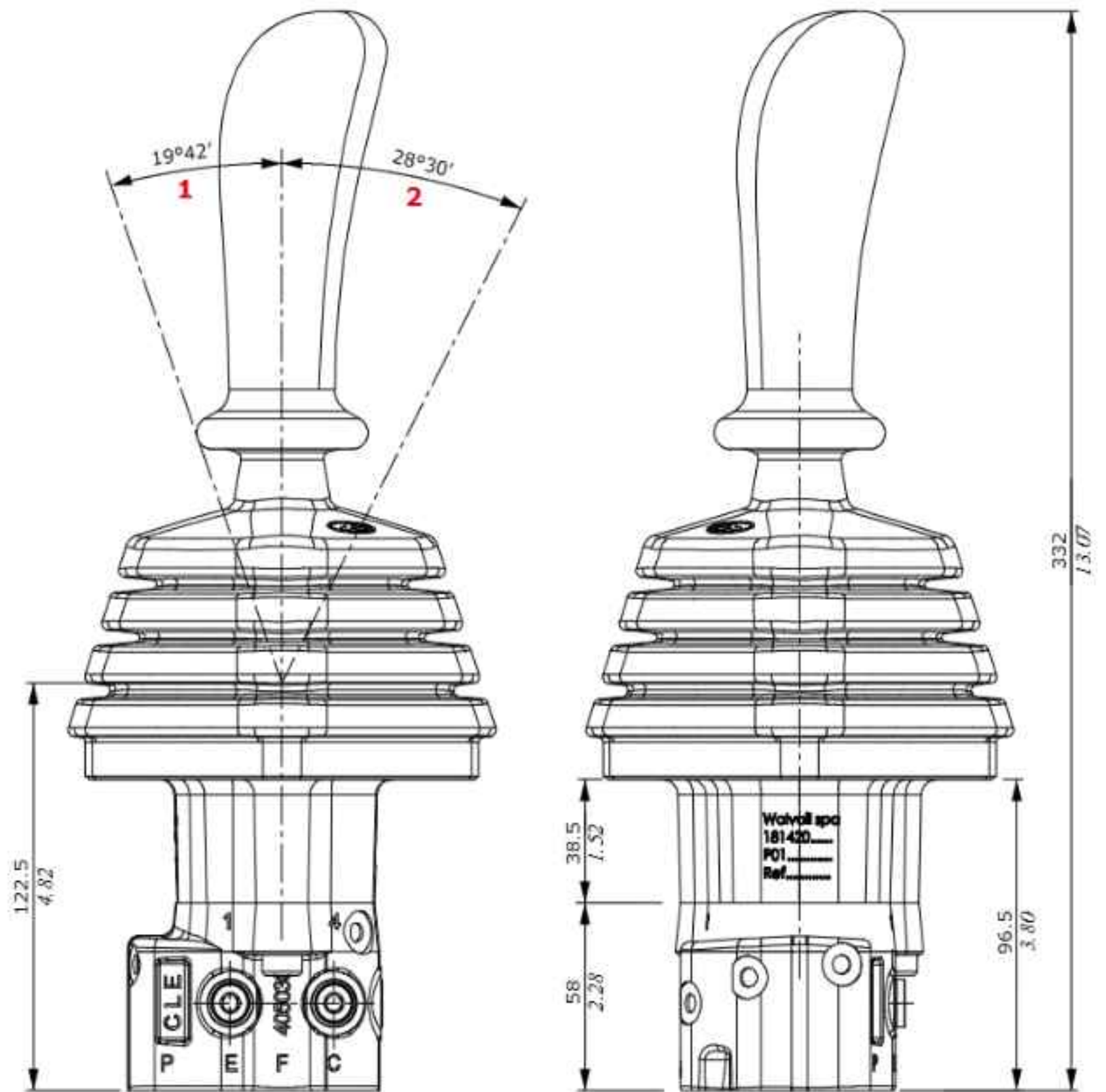

1 : Single work port
 2 : Two simultaneous work ports

Dimensions and hydraulic circuit

SVM431

SVM431 it's configured with pressure gauges (5) to get an additional output signal with safety solenoid valve.

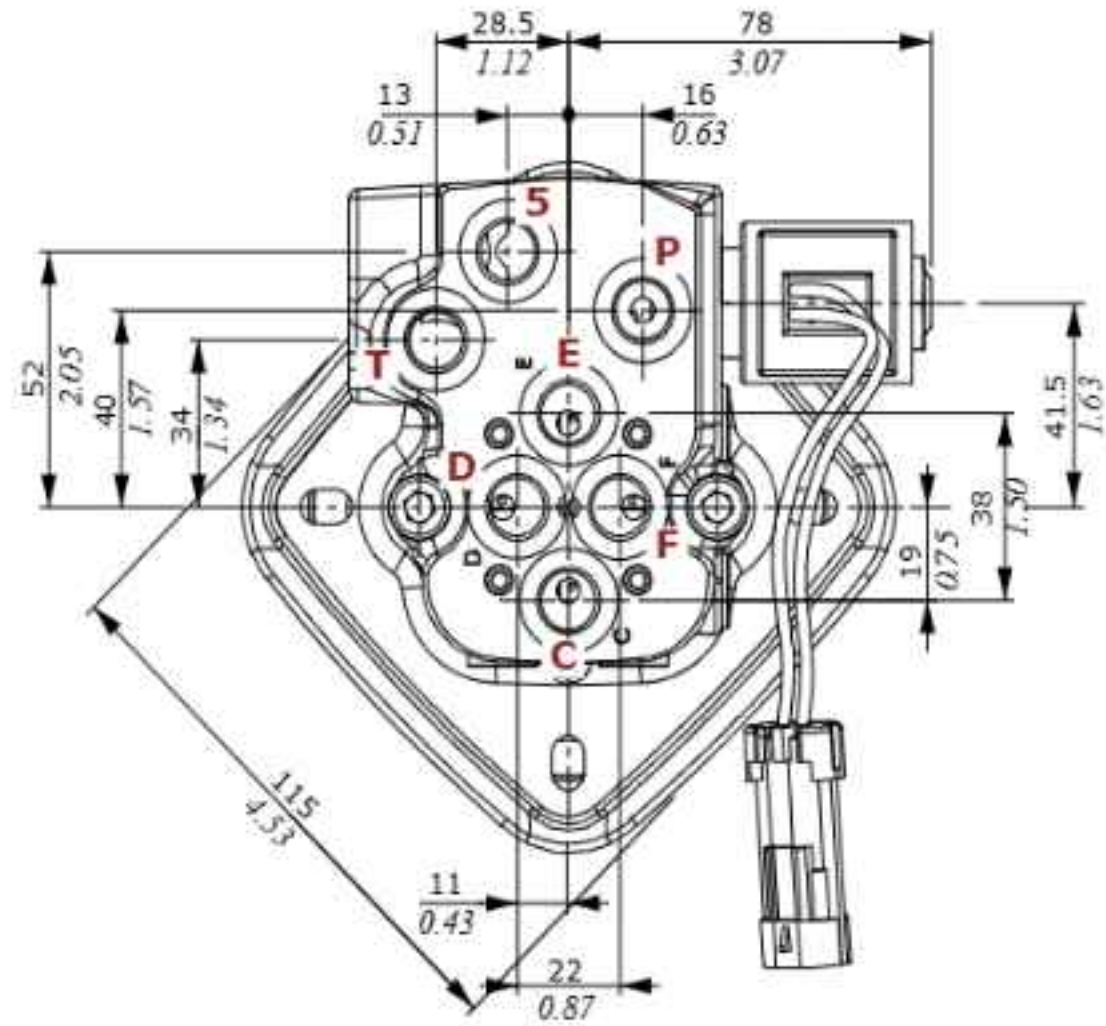

Hydraulic circuit

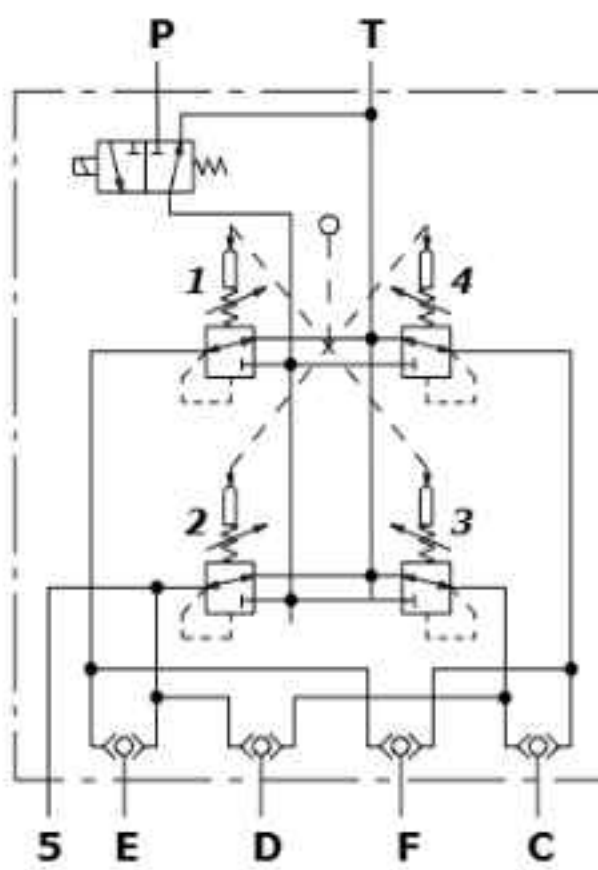

- Work port 1 ⇒ EF port ⇒ right
- Work port 2 ⇒ ED port ⇒ back
- Work port 3 ⇒ CD port ⇒ left
- Work port 4 ⇒ CF port ⇒ forward

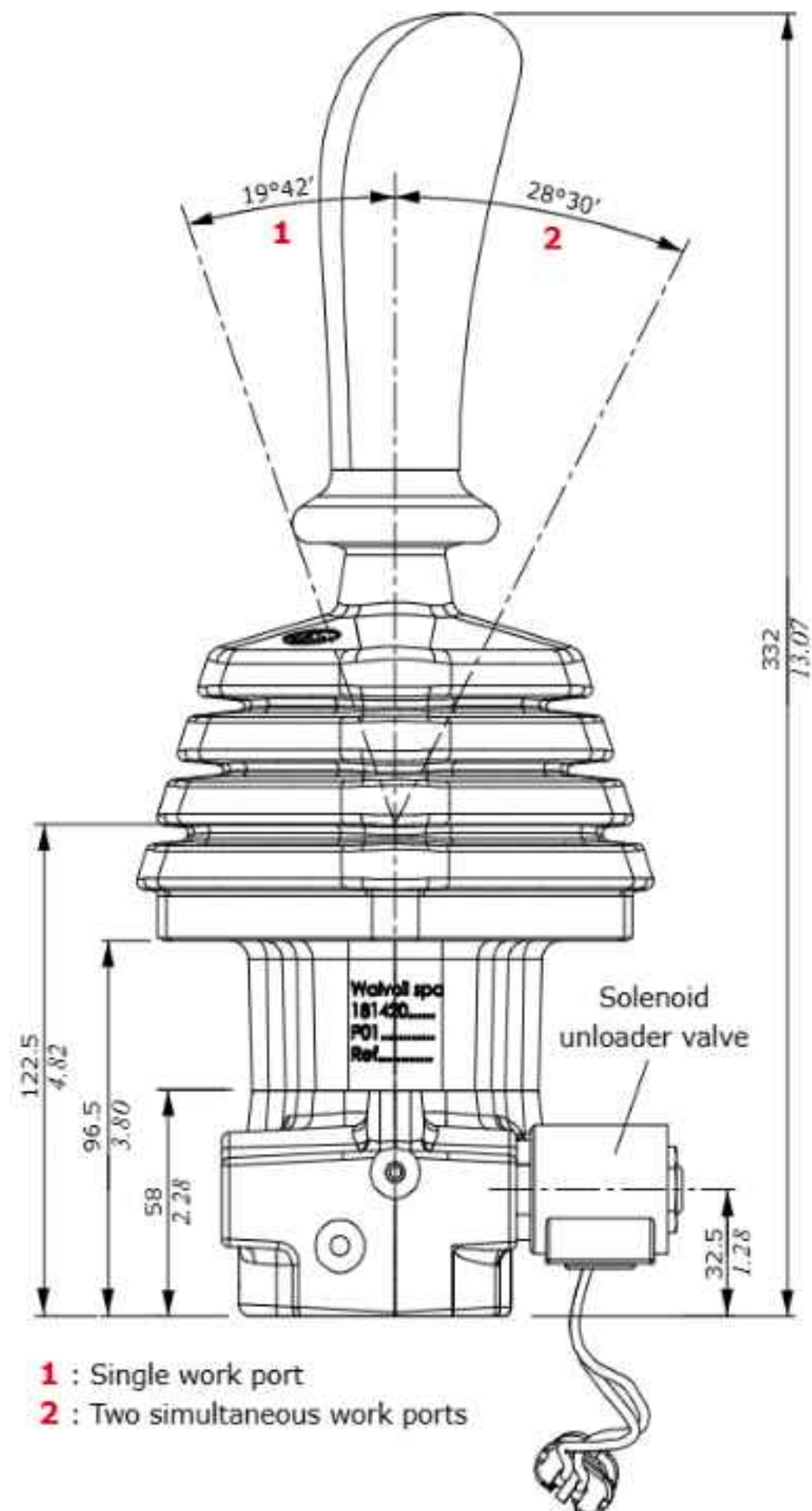

Dimensions and hydraulic circuit

SVM432

SVM432 it's configured with solenoid unloader valve and auxiliary under safety pressure gauge port (P1).

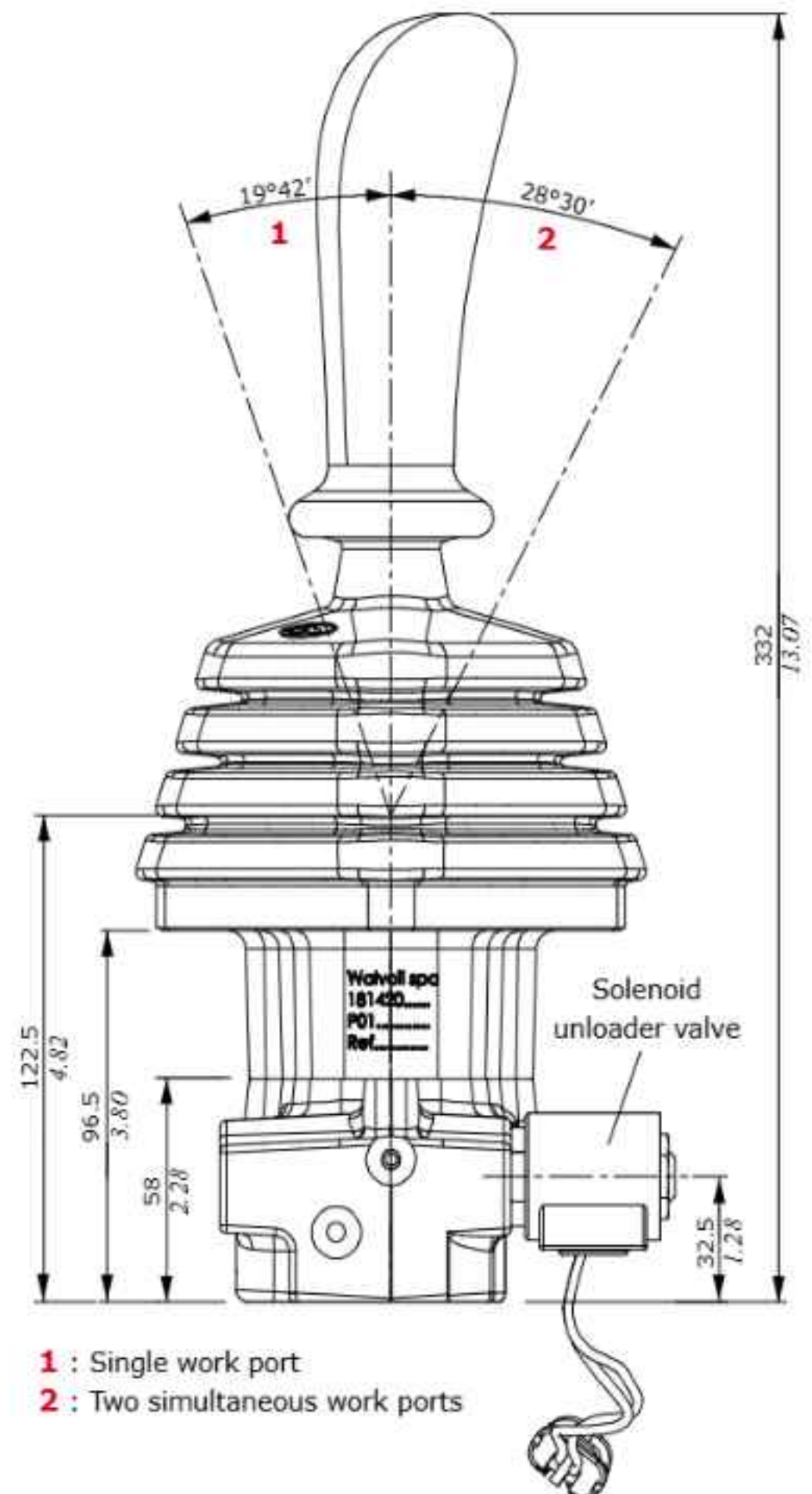
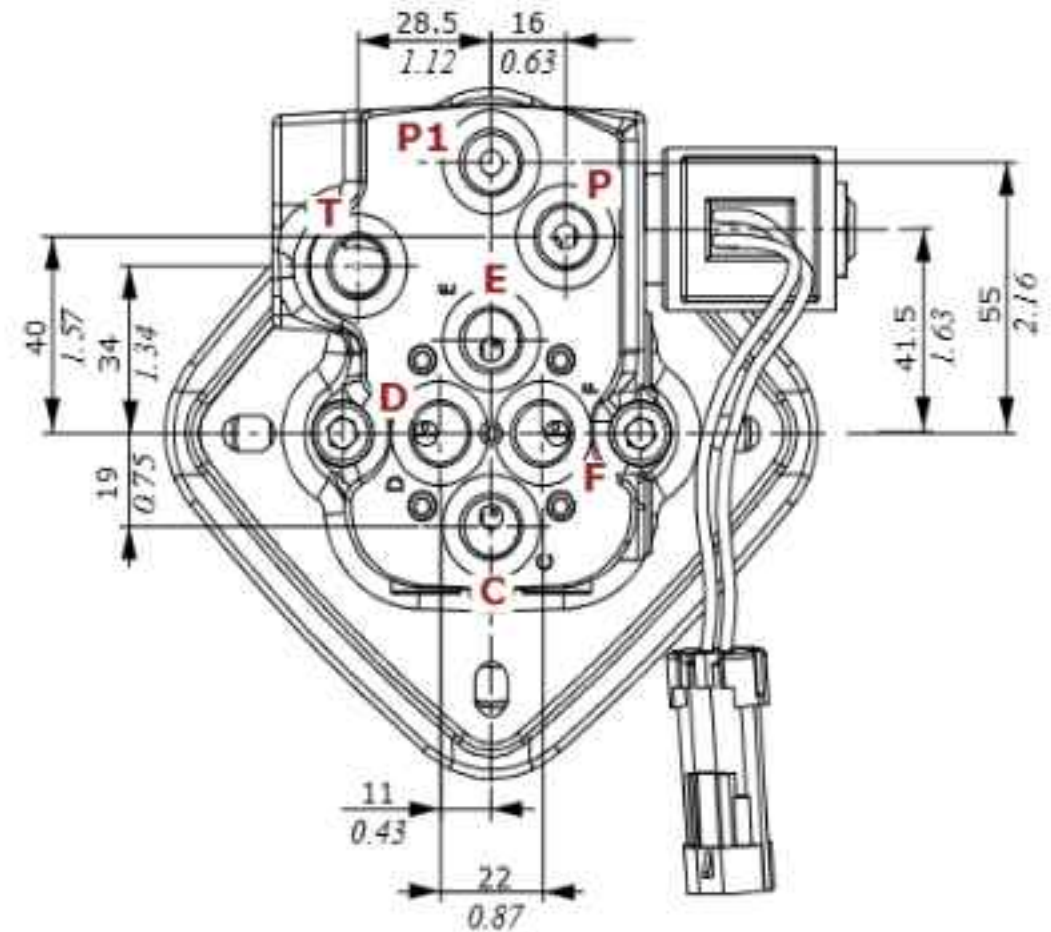

Hydraulic circuit

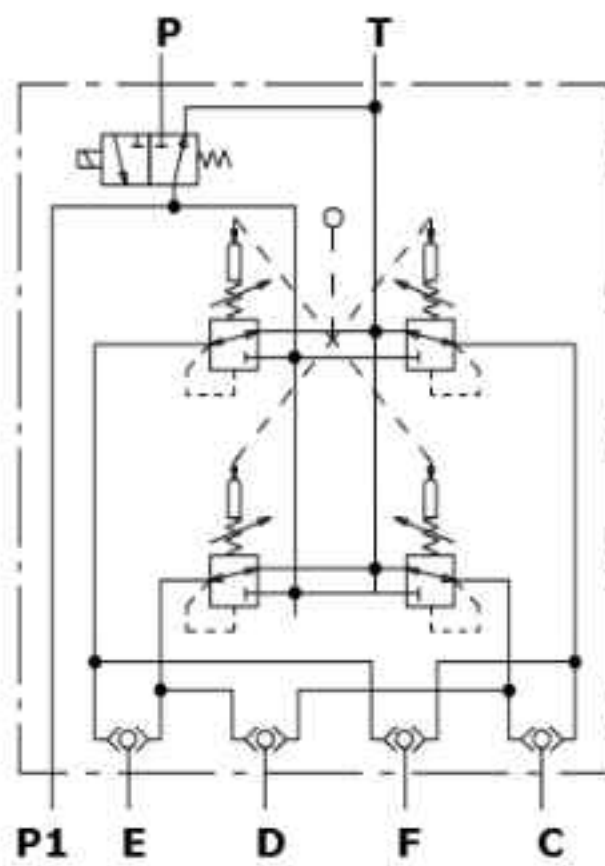

- Work port 1 ⇒ EF port ⇒ right
- Work port 2 ⇒ ED port ⇒ back
- Work port 3 ⇒ CD port ⇒ left
- Work port 4 ⇒ CF port ⇒ forward

Ordering codes

SVM400 / 0 1 - B / 01 V009 (90) - 0 0 001 A X 4 - <CRVN>

1 2 1 3 4 5 6

Body is painted as standard, with one coat of primer black antirust paint

SVM431 / 0 1 - B / 01 V009 (90) - 0 0 001 A - ELN (W1F02)-12VDC - <CRVN>

6.1 6.2 6.3 6.4 7 8

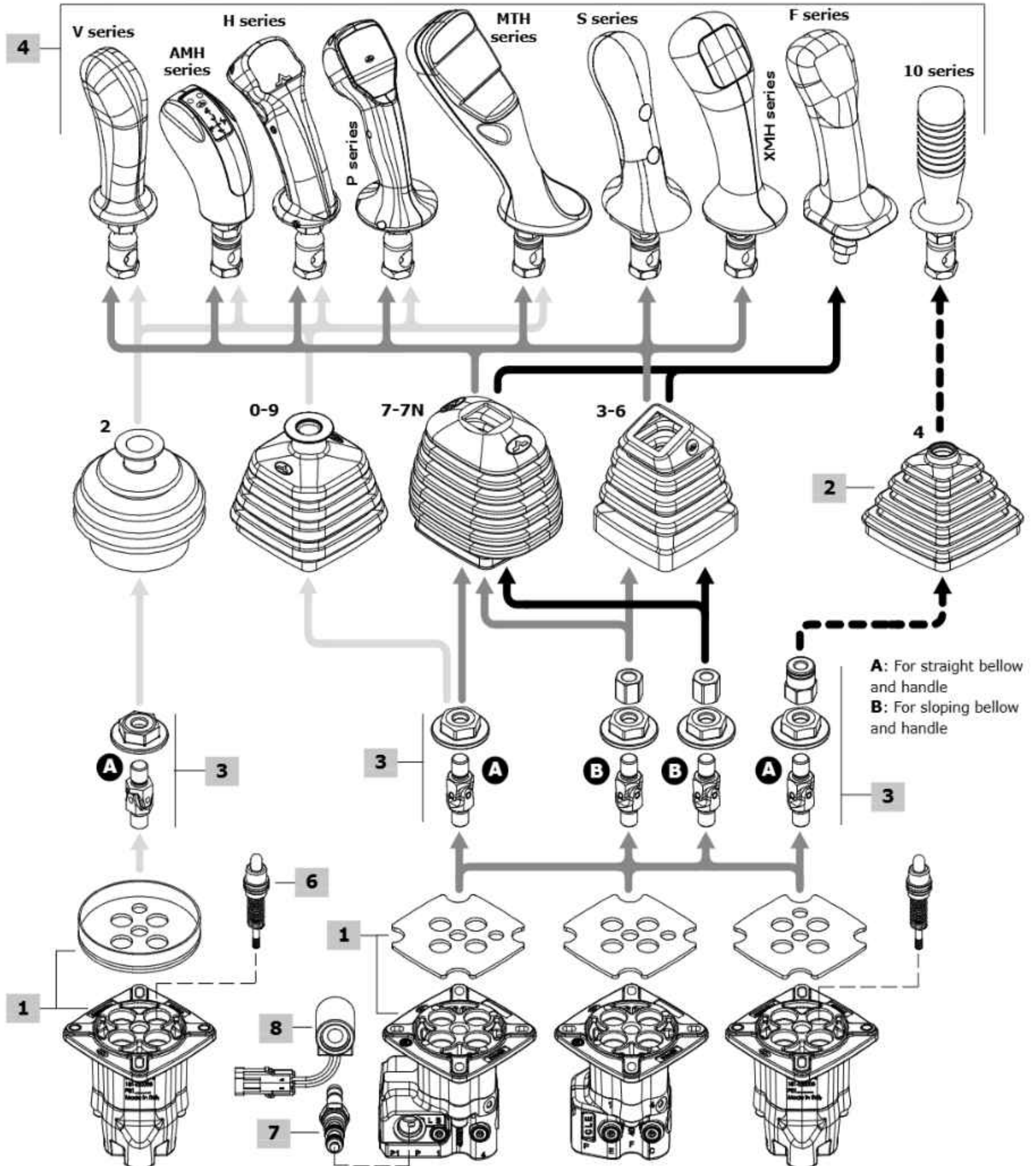

1 Body kit *

TYPE	CODE	DESCRIPTION
With arrangement for circular base rubber bellow		
SVM400/3-B	5C03422300C	For circular base rubber bellow
With arrangement for square base rubber bellow		
SVM400/1-B	5C03422300	For square base rubber bellow
SVM400/1-B	5C03422301	As previous one, arranged for control type 16
SVM400/1A-B	5C03422305	For square base rubber bellow, with one open ring
SVM430/1-B	5C03432302	With auxiliary pressure gauge port
SVM431/1-B	5C03432310	With auxiliary pressure gauge port and solenoid unloader valve
SVM432/1-B	5C03432320	With auxiliary under-safety pressure gauge port and solenoid unloader valve

2 Rubber bellow

TYPE	CODE	DESCRIPTION
Circular base type		
2	3SOF110100	Straight type; it can be used with sloping handles
Square base type		
0	3SOF111130	Straight type with logo
3	3SOF111113	Sloping type with logo, only for 19° sloping handles. Not available for type 16 control
6	3SOF111114	As type 3, without logo. Not available for type 16 control
7	3SOF111135	General purpose type with logo; it can be used straight or up to 30° sloping in all directions
7N	3SOF111137	As type 7 without logo.
9	3SOF111131	As type 0 without logo.
4	3SOF111100	Straight type

3 Control option

TYPE	CODE	DESCRIPTION
With spring return in neutral position		
01	5CIN4003	For handles with straight rubber bellow (not for Series 10 and F handles)
	5CIN4001	For handles with sloping rubber bellow (not for Series 10 and F handles)
01GP	5CIN4002	For series 10 handles
01	5CIN401F00	For series F handles
With microswitches for movement detection on each port: It needs type 7/7N rubber bellow and dedicated body kit (see ch.1)		
16	5CIN4023	For handles with straight rubber bellow (not for Series 10 and F handles)
	5CIN4021	For handles with sloping rubber bellow (not for Series 10 and F handles)

4 Handles

Some handles as examples are listed below: for technical specifications and full range of handles and other types of joint see the "Handles and hand levers" catalogue.

V series handle

TYPE: **V007-(Q)** CODE: 5IMP030071
DESCRIPTION: Without switches, with sloping 19° left joint and square seat bellow adapter

AMH series handle

TYPE: **AMH0400A9-6R2035(T)-7R2035(T)-8R2035(T)-9R2035(T)-(E2)** CODE: 2IM3000004
DESCRIPTION: 4 spring return push-buttons, protection diode, flying leads, straight joint and square seat bellow adapter

H series handle

TYPE: **HA029-ORD040-2RD040-4RD040** CODE: 2IM4100109
DESCRIPTION: 2 microswitch push-buttons on the operator side, "dead man" switch, flying leads, straight joint, for circular seat bellow

P series handle

TYPE: **PZTA4100D9-ORD035-3R1D035-4R1D035-5R1D035-6R1D035-WN130035** CODE: 2IM8600007
DESCRIZIONE: 1 proportional roller and 4 spring return push-buttons on operator side, "dead man" switch, flying leads, straight joint for circular seat bellow

NOTE (*) - Codes are referred to **BSP** thread.

4(bis) Handles**MTH series handle**

TYPE: **MTH-R00-ZTM31009-00-3N2035-5R2035-6N2035-7N2035-8N2035-DY2035-WG130035-(D2F12)**
CODE: 2IM2000012

DESCRIPTION: 1 proportional roller and 3 spring return push-buttons on the operator side, 3 push buttons on the opposite side, straight joint, for circular seat bellow, Deutsch connector

XMH series handle

TYPE: **XMHZTA21008-2G2035-4G2035-7G2035-VG171035**
CODE: 2IM1000004

DESCRIPTION: 1 proportional roller and 2 spring return push-buttons on the operator side, 1 push button with spring return on the opposite side, Deutsch connector, 19° sloping right joint, for square seat bellow

S series handle

TYPE: **SZTA8-0G4045-XG122045** CODE: 2IM5310003

DESCRIPTION: With prop. roller on the operator side and spring return push-button on the opposite side, 19° sloping right joint, for square seat bellow

F series handle

TYPE: **F02F-02R(1=8)** CODE: 320000251

DESCRIPTION: 2 microswitch push-buttons on the operator side and 2 on the opposite side, flying leads, 15° sloping joint, square seat bellow adapter, requires dedicated control

5 Handle position

TYPE	DESCRIPTION
(-)	STANDARD configuration, forward operation to port 4: omitted in description
(90)	Mounted with 90° rotation step: forward operation towards port 1
(180)	Mounted with 180° rotation step: forward operation towards port 2
(270)	Mounted with 270° rotation step: forward operation towards port 3

6 Pressure control curves

For list available see from page 27

6.1 Curve type

TYPE	DESCRIPTION
0	Standard

6.2 Typology of curves

TYPE	DESCRIPTION	TYPE	DESCRIPTION
0	With step	2	Piecewise with step
1	Without stepp	3	Piecewise without step

6.3 Curve identification

Progressive number

6.4 Return springs

TYPE	DESCRIPTION
M	Operation range from 18 to 25.5 N - <i>from 4.04 to 5.73 lbf</i>
A	Operation range from 23 to 35.2 N - <i>from 5.17 to 7.91 lbf</i>
B	Operation range from 23 to 68.1 N - <i>from 5.17 to 15.31 lbf</i>
C	Operation range from 89 to 176 N - <i>from 20 to 39.56 lbf</i>
D	Operation range from 110 to 220 N - <i>from 24.73 to 49.46 lbf</i>
E	Operation range from 137.8 to 276.1 N - <i>from 31 to 62.07 lbf</i>

7 Solenoid unloader valve

TYPE	CODE	DESCRIPTION
ELN	2X4800100	Without emergency operation
ELT	2X4800200	With emergency operation

8 Coil

TYPE	CODE	DESCRIPTION
(D1F02)-12VDC	4SL6001200	12VDC, integrated Deutsch connector
(D1F02)-24VDC	4SL6002400	As previous one, 24VDC
(W1F02)-12VDC	4SL6001204	12VDC, WP Packard connector with flying leads (L= 210 mm - 8.27 in)

Configuration option

Control and handle options

01 type: Spring return in neutral position.

16 type: With microswitches for movement detection on each port. It needs type 7 rubber bellow and special body: please contact our Sales Department.

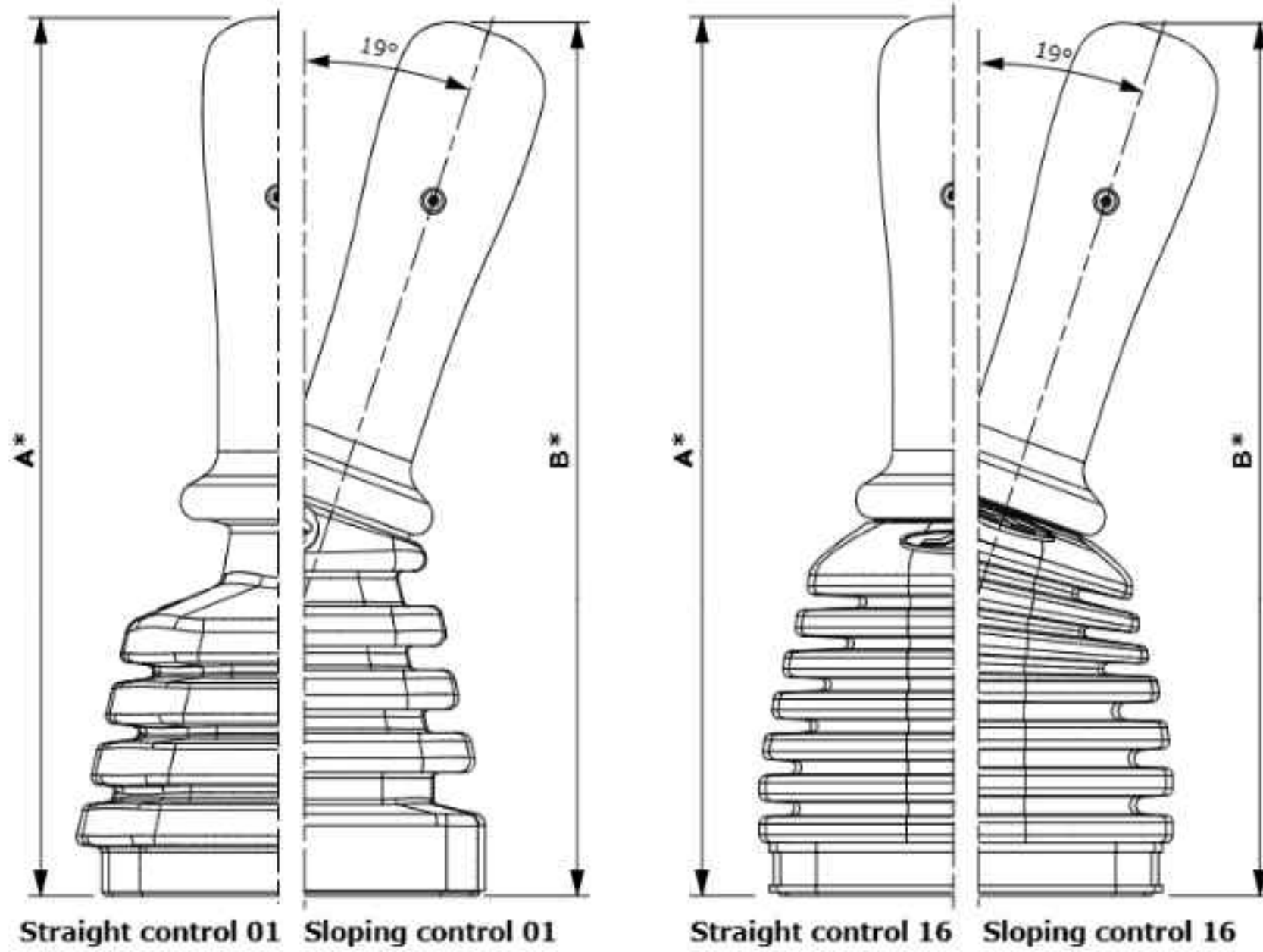

Type	A*		B*	
	mm	in	mm	in
V series	238	9.71	236	9.29
AMH series	194	7.64	194	7.64
H series	236	9.29	234	9.21
P series	255	10.04	253	9.96
MTH series	262	10.31	250	9.84
S series	251	9.88	248	9.76
XMH series	260	10.24	256	10.08
F series	242	9.52	238	9.37
10 series	222	8.74	/	/

(*) The overall dimensions are indicative

Control type 16 electrical diagram

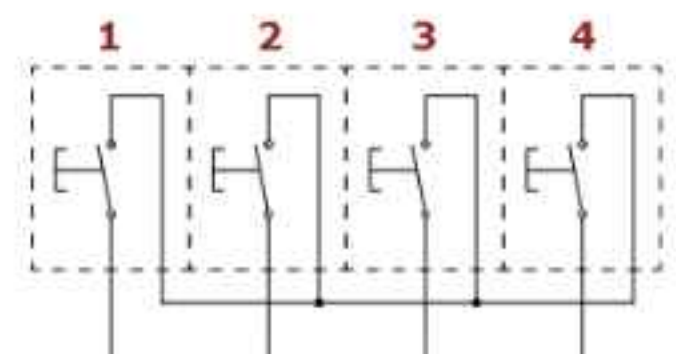

Handles positions

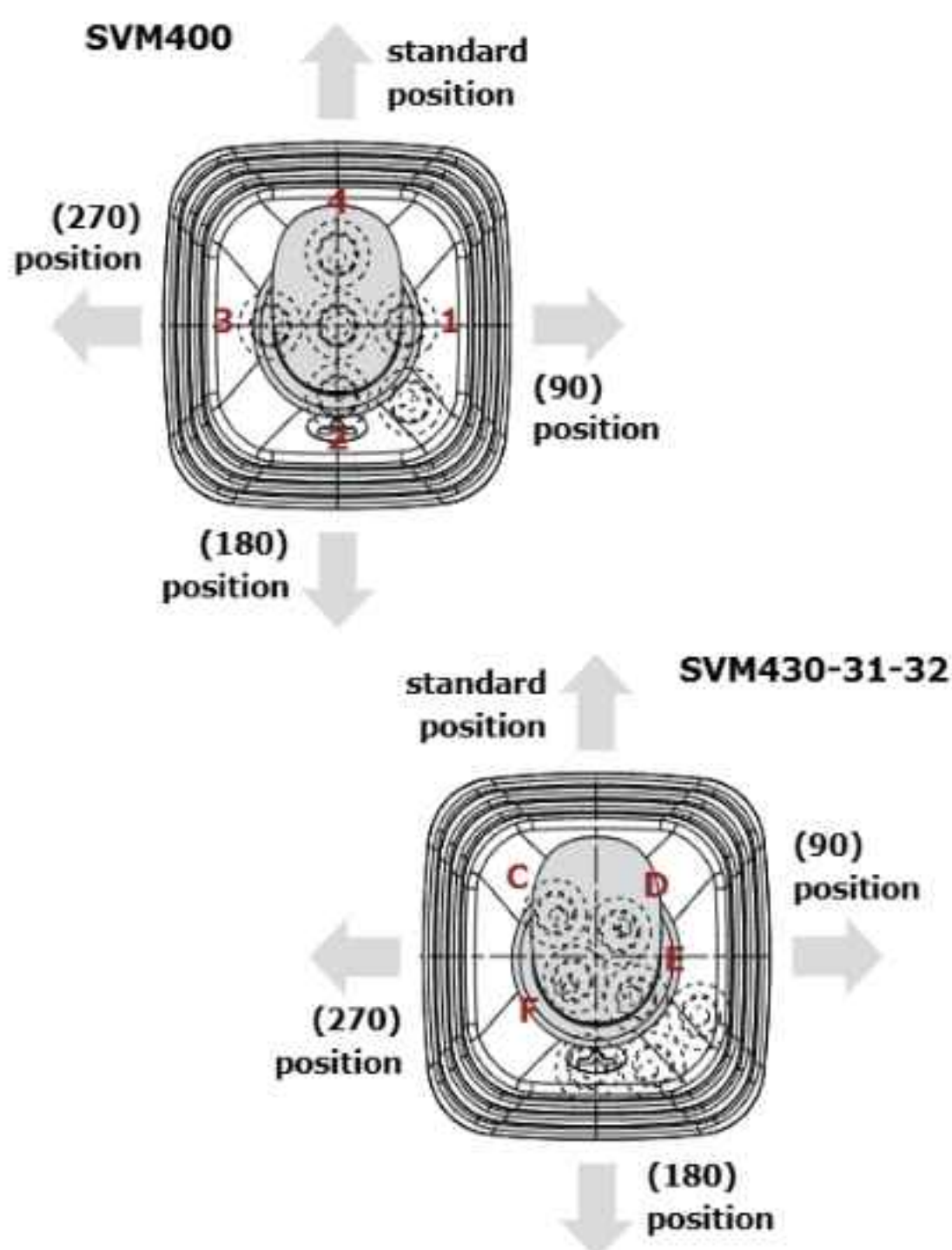

Solenoid unloader valve

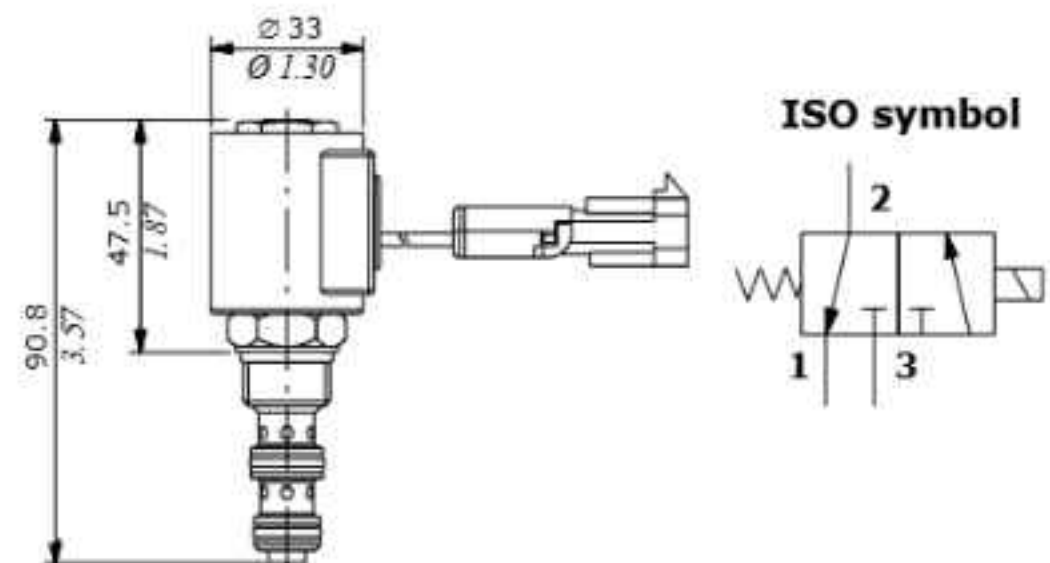

Features

SOLENOID VALVE

- Nominal pressure : 207 bar - 14.27 psi
- maximum internal leakage
on port 3 (de-energized coil) : 82 cm³/min a 207 bar
5 in³/min at 14.27 psi
- on port 1 (energized coil) : 164 cm³/min a 207 bar
10 in³/min at 14.27 psi

COIL

- Nominal voltage tolerance : ±15%
 - Power rating : 14.7 W
 - Max. operating current : 1.22 A a 12 VDC
0.61 A a 24 VDC
 - Coil insulation : Class H
 - Weather protection (EN 60529) : IP65 *
 - Insertion : 100%
- (*) with connector correctly fitted and O-ring protection

Ordering codes

SVM400-EMD1 / 7 1 - B / 01E15 (....) V00G (90) (....) - E 0 001 M - 00001M X 3 - 12VDC - <CRVN>

1
 2 1 3 7 4 5 7 6.1 6.2 6.3 6.4 6 3

4
 6

Body is painted as standard, with one coat of primer black antirust paint

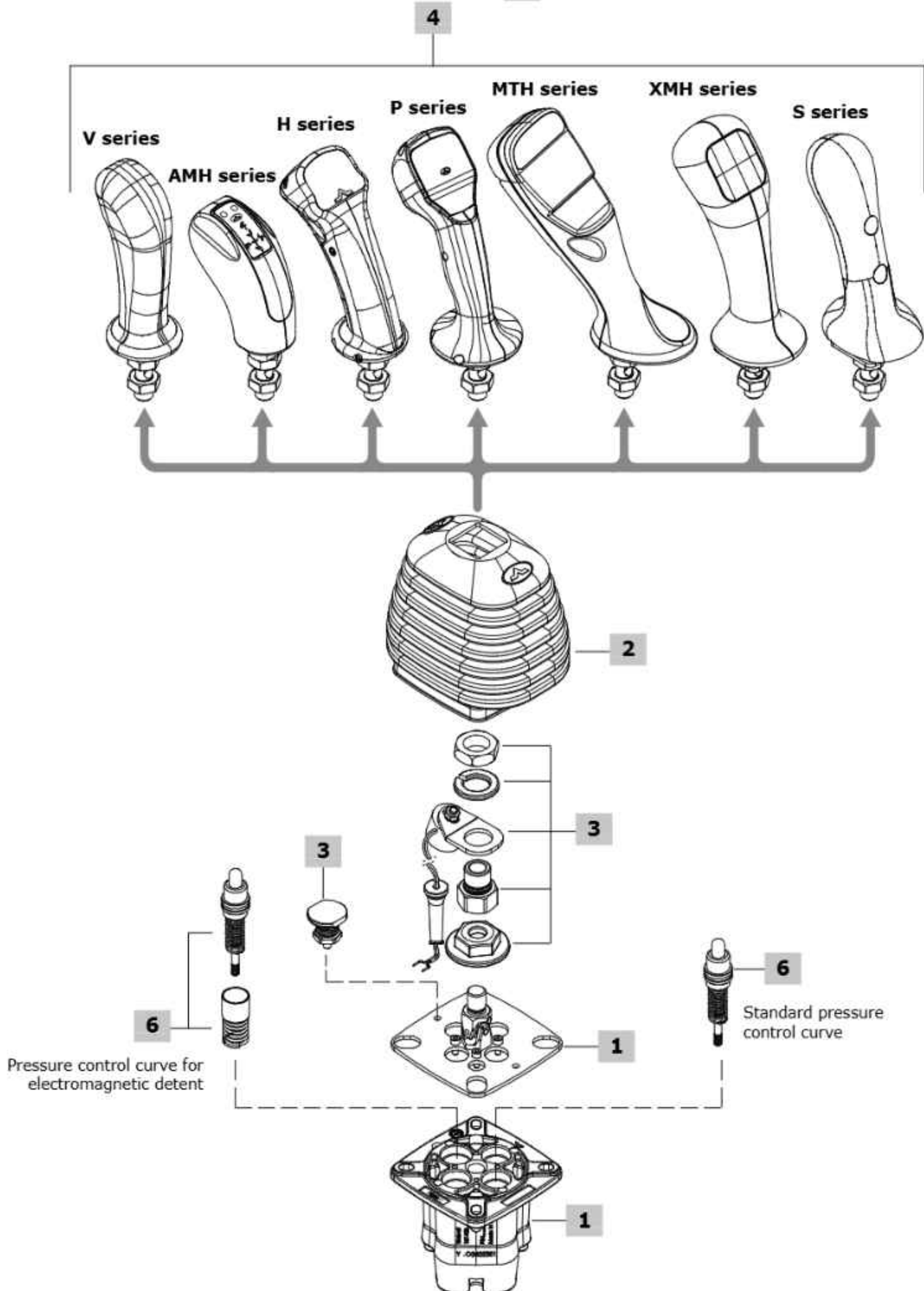

1 Body kit *

TYPE: **SVM400-EMD0/1-B** CODE: 5CO3422300
 DESCRIPTION: Without detent arrangement
 TYPE: **SVM400-EMD1/1-B** CODE: 5CO3402301
 DESCRIPTION: With detent arrangement on port 1
 TYPE: **SVM400-EMD6/1-B** CODE: 5CO3402306
 DESCRIPTION: With detent arrangement on ports 2 and 4

2 Rubber bellow

7 3SOF111135 Universal type, rectangular base. With logo and it can be used straight and 30° sloping in all directions
7N 3SOF111137 As type 7 without logo

3 Detent configuration

Cables are supplied with wires with tin-plate terminals

TYPE	CODE	DESCRIPTION
01E0	5CIN401E00	Spring return, without detent

Detent on port 1

01E15	5CIN401E12	12 VDC - Spring return
01E15	5CIN4E401100	24 VDC - Spring return

Detent on ports 1, 3 or 2, 4

01E25	5CIN401E22	12 VDC - Spring return
01E25	5CIN4E401200	24 VDC - Spring return

NOTE: For detent on different ports please contact our Sales Department.

6 Pressure control curves

For list available see from page 27

6.1 Curve type

TYPE	DESCRIPTION
0	Standard, without electromagnetic detent
E	For electromagnetic detent, with pre-feeling

6.2 Typology of curves

TYPE	DESCRIPTION
0	With step
1	Without step
2	Piecewise with step
3	Piecewise without step

6.3 Curve identification

Progressive number

6.4 Return springs

TYPE	DESCRIPTION
M	Operation range from 18 to 25.5 N - <i>from 4.04 to 5.73 lbf</i>
A	Operation range from 23 to 35.2 N - <i>from 5.17 to 7.91 lbf</i>
B	Operation range from 23 to 68.1 N - <i>from 5.17 to 15.31 lbf</i>

7 Connector

Configurations with detent or microswitch are provided with wires with tin-plate terminals. For connectors please contact our Sales Department

4 Handles

Some handles as examples are listed below: for technical specifications and full range of handles and other types of joint see the "Handles and hand levers" catalogue.

V series handle

TYPE: **V007-(Q)**
 CODE: 5IMP030071
 DESCRIPTION: Without switches, with 19° sloping left joint and square seat bellow adapter

AMH series handle

TYPE: **AMHT0300A8-(Q)-6N2D035-7R2D035-8N2D035-(E1)**
 CODE: 2IM3000007
 DESCRIPTION: 3 spring return push-buttons on the operator side, flying wires, 19° sloping right joint, square seat bellow adapter

H series handle

TYPE: **HMB03G-(Q)-1R4040-4R3040-5R2040-(12VDC)**
 CODE: 2IM4600051
 DESCRIPTION: 3 spring return push-buttons on the operator side, flying wires, straight joint, square seat bellow adapter

P series handle

TYPE: **PZMA1200B7-0R035-3Y2D035-WN130035-ZN130035-(SCHEDA 2PWM)-(TD2M)**
 CODE: 2IM8700003

DESCRIPTION: 2 proportional rollers and 1 spring return push-button on the operator side, "dead man" switch, flying wires with Deutsch pins, 19° sloping left joint, square seat bellow adapter

MTH series handle

TYPE: **MTH-R00-ZTI4100(K)Y-00-1Y2035-2Y2035-3N2035-6N2035-ZN122035-MRZ035-(5VDC)-D2F12**
 CODE: 2IM2000005

DESCRIPTION: 1 proportional roller and 4 spring return push-buttons on operator side, 1 FNR rocker on the opposite side, Deutsch connector, 9° sloping left joint, square seat bellow adapter

XMH series handle

TYPE: **XMHZTA21008-2G2035-4G2035-7G2035-VG171035**
 CODE: 2IM000004

DESCRIPTION: 1 proportional roller and 2 spring return-push buttons on the operator side, 1 spring return push button on the opposite side, Deutsch connector, 19° sloping right joint, for square seat bellow

S series handle

TYPE: **SZTA8-0G4045-XG122045**
 CODE: 2IM5310003

DESCRIPTION: With proportional roller on the operator side and spring return push-button on the opposite side, 19° sloping right joint, for square seat bellow

5 Handle position

TYPE	DESCRIPTION
(-)	STANDARD configuration, forward operation towards port 4: omitted in description
(90)	Mounted with 90° rotation step: forward operation towards port 1
(180)	Mounted with 180° rotation step: forward operation towards port 2
(270)	Mounted with 270° rotation step: forward operation towards port 3

NOTE (*) - Codes are referred to **BSP** thread.

Configuration option

Handle options

Handle positions

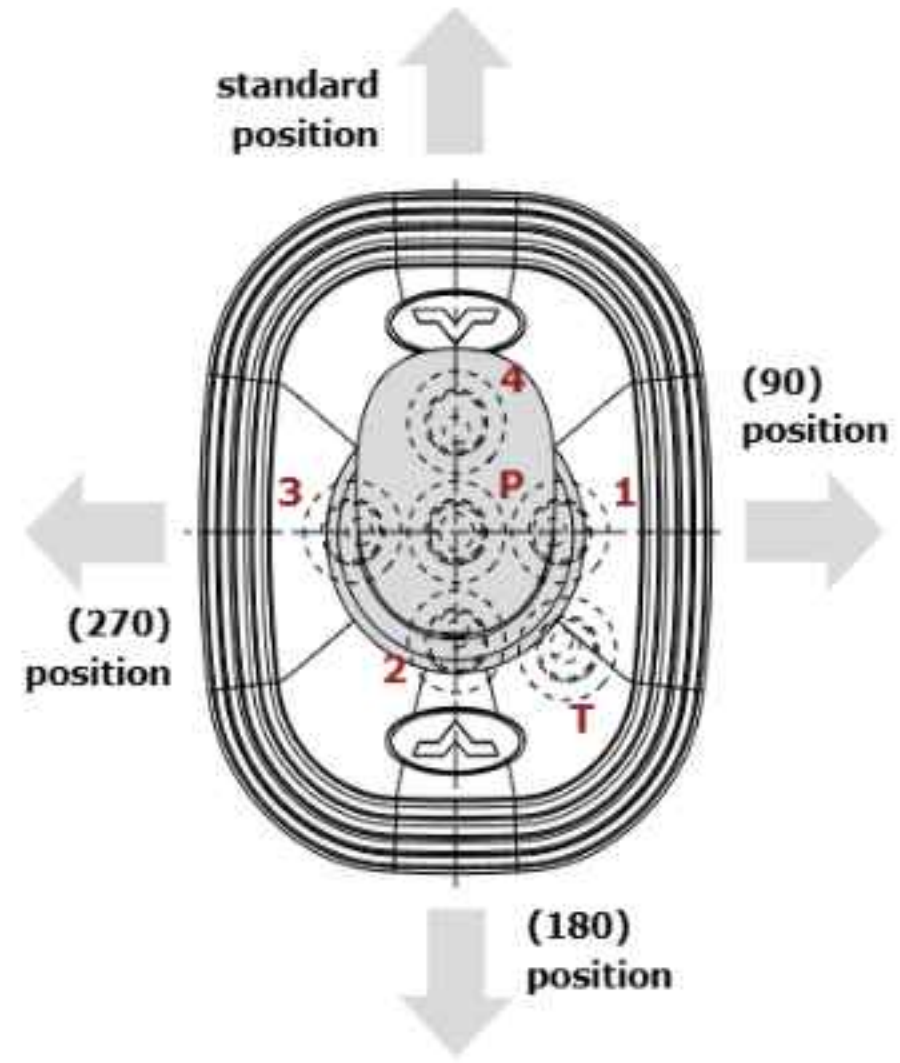
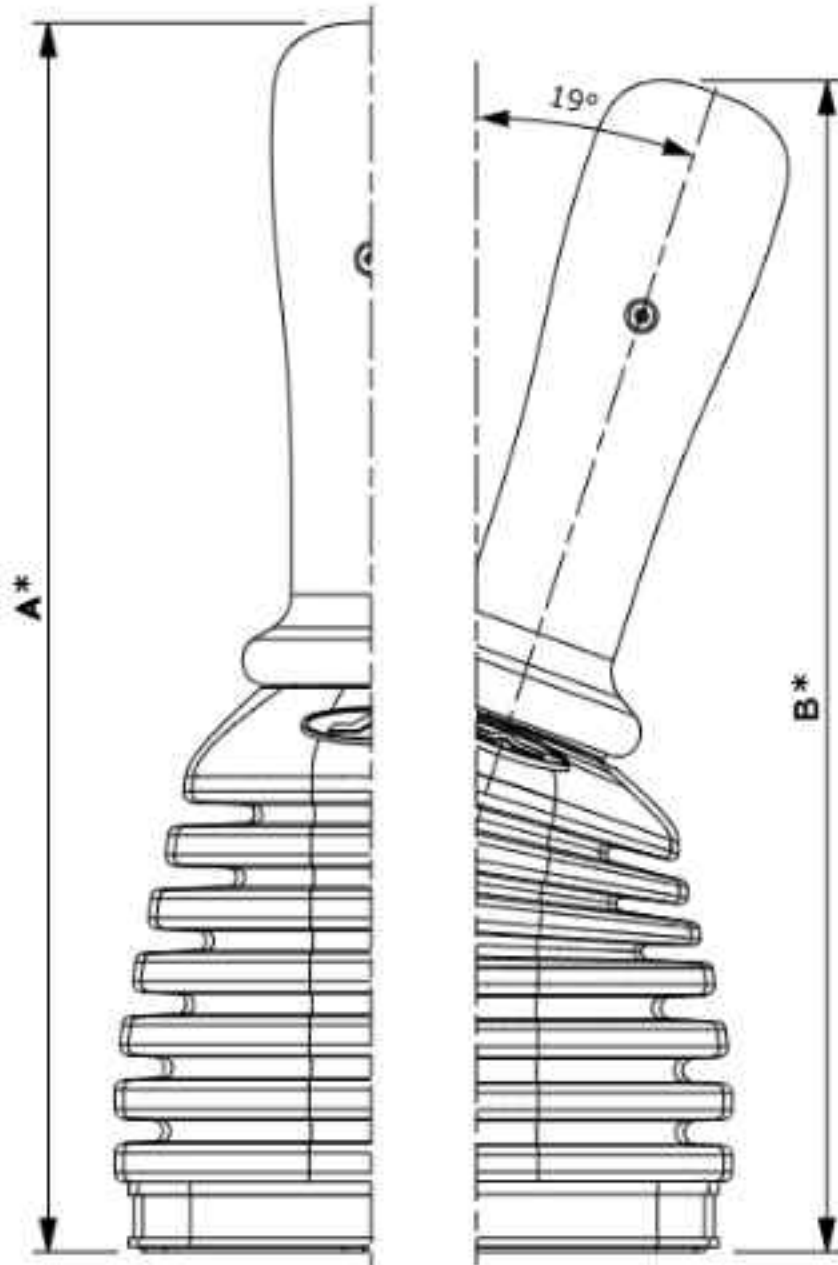

Type	A*		B*		Type	A*		B*	
	mm	in	mm	in		mm	in	mm	in
V series	252	9.92	240	9.45	MTH series	275	10.83	271	10.67
AMH series	209	8.23	201	7.91	S series	266	10.47	261	10.27
H series	250	9.84	240	9.45	XMH series	275	10.83	264	10.39
P series	268	10.55	266	10.47	(*) The overall dimensions are indicative				

Detent configuration

01E0 type

Spring return, without detent

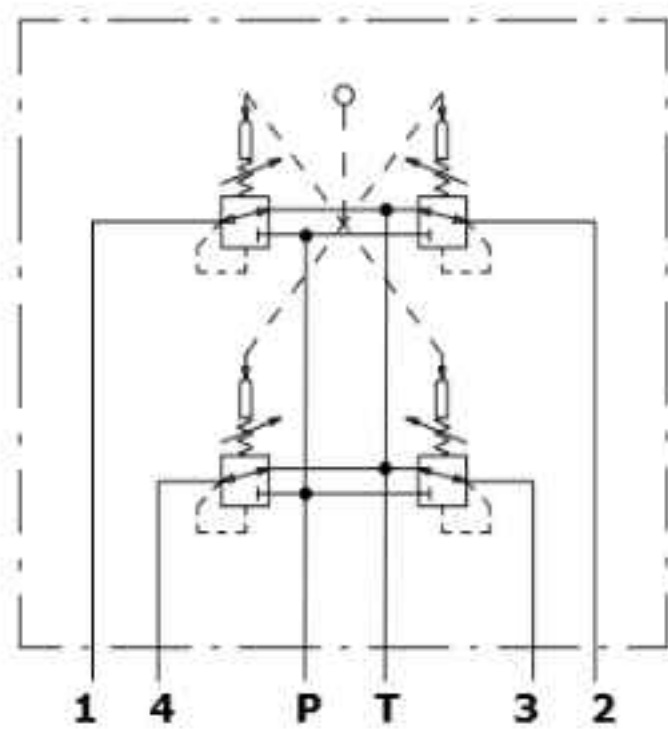

01E15 type

Single detent on port 1
(detent on ports 2-3-4 on request),
spring return

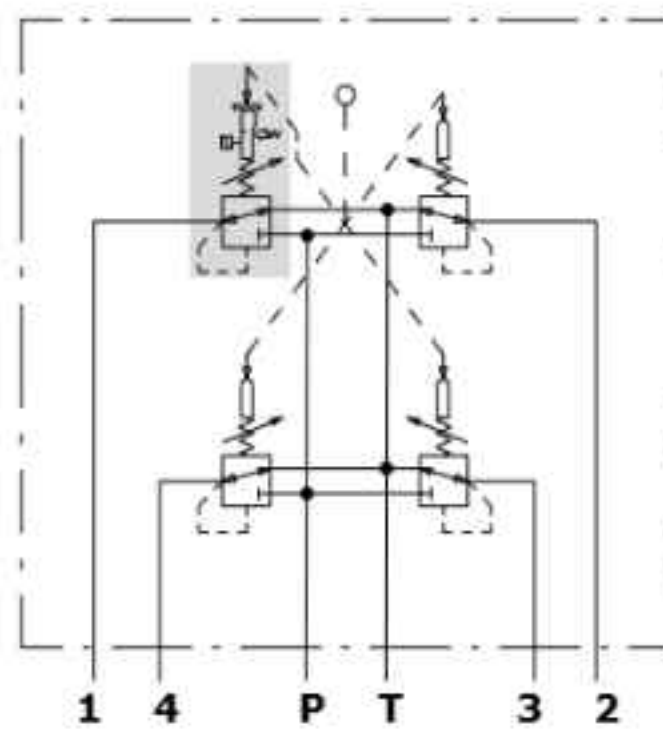

01E25 type

Detent on ports 2 and 4, spring return

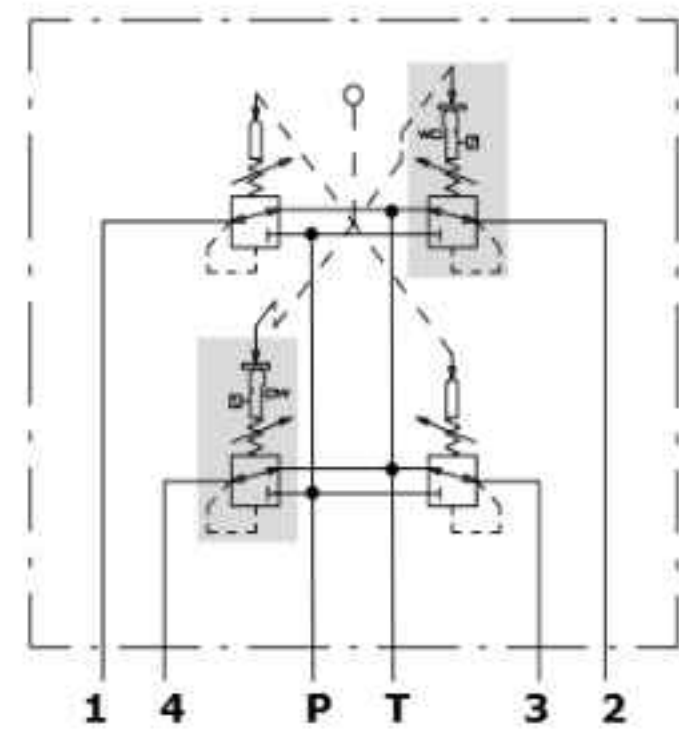

Control curves with step

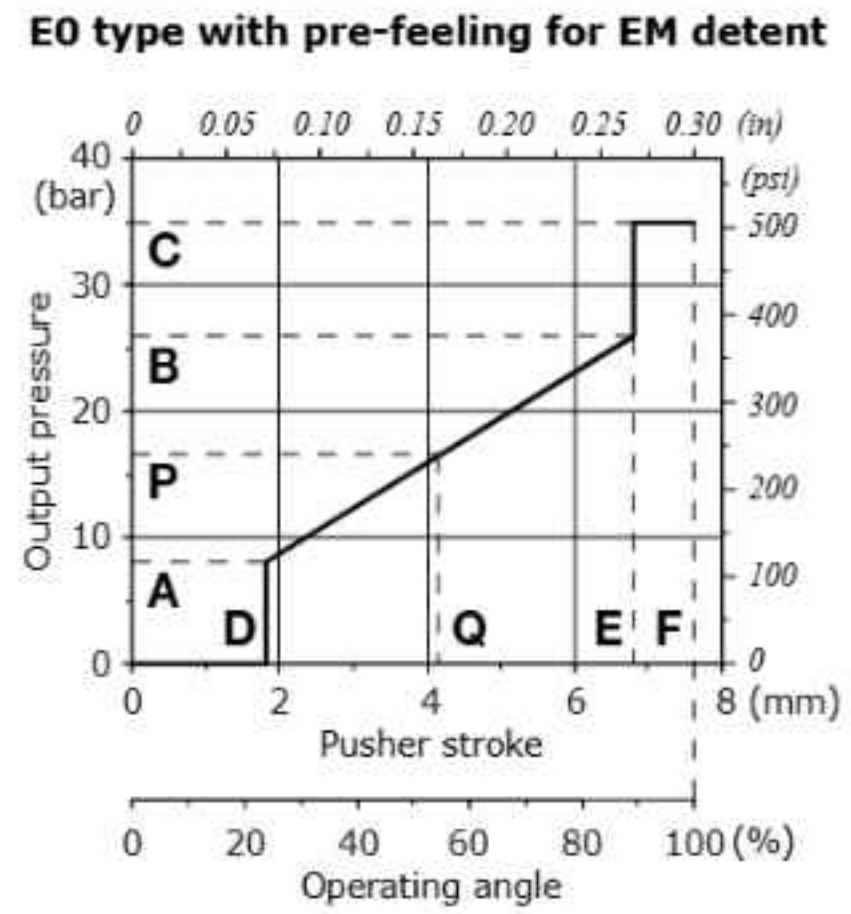
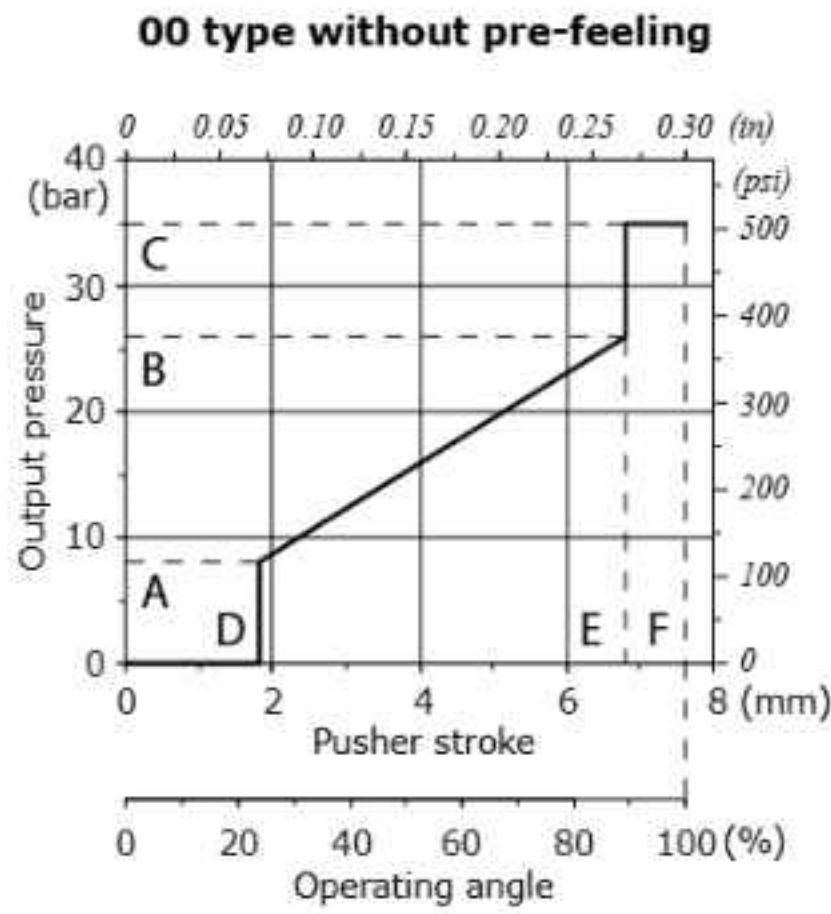

Curve description		Pressure						Stroke								CODE ⁽¹⁾		
Type	Nr	A		P		B		C		D		Q		E			F	
		bar (±tol)	psi (±tol)	bar (±tol)	psi (±tol)	bar (±tol)	psi (±tol)	bar	psi	mm	in	mm	in	mm	in	mm	in	
Without pre-feeling																		
00	019	0.5 (+1, -0.5)	7.25 (+14.5, -7.25)			11.4 (±1)	165.3 (±14.5)	35	507.5	0.85	0.03			7.25	0.28	7.6	0.30	5SCR400019A
00	022	1 (±0.5)	14.5 (±7.25)			8 (±1)	116.3 (±14.5)	35	507.5	0.85	0.03			7.25	0.28	7.6	0.30	5CUR40022A
00	023	2 (±0.5)	29 (±7.25)			11.5 (±1)	166.7 (±14.5)	35	507.5	0.85	0.03			7.25	0.28	7.6	0.30	5CUR40023A
00	047	2 (+3/0)	29 (+43.5/0)			70 (±4.5)	1015 (±65.2)	75	1088	0.85	0.03			7.25	0.28	7.6	0.30	5CUR40047A 5CUR40047C
00	065	2 (±0.5)	29 (±7.25)			20.5 (±1.5)	297.25 (±21.7)	35	507.5	0.85	0.03			7.25	0.28	7.6	0.30	5CUR40065A
00	066	2 (±0.5)	29 (±7.25)			23 (±1.5)	333.5 (±21.7)	35	507.5	0.85	0.03			7.25	0.28	7.6	0.30	5CUR40066B 5CUR40066C
00	110	2 (±0.5)	29 (±7.25)			15 (±1)	217.5 (±14.5)	35	507.5	0.85	0.03			7.25	0.28	7.6	0.30	5SCR400110A
00	043	3.2 (±0.5)	46.4 (±7.25)			11.7 (±0.5)	169.6 (±7.25)	35	507.5	0.85	0.03			7.25	0.28	7.6	0.30	5SCR400043A
00	010	3.25 (±0.5)	74.13 (±7.25)			14.8 (±1)	214.6 (±14.5)	35	507.5	0.85	0.03			7.25	0.28	7.6	0.30	5CUR40010A 5CUR40010M
00	032	3.4 (±0.5)	49.3 (±7.25)			29.4 (±1)	426.3 (±14.5)	35	507.5	0.85	0.03			7.25	0.28	7.6	0.30	5CUR40032A 5CUR40032B 5CUR40032C
00	086	4 (±1)	58 (±14.5)			16.5 (±1)	239.2 (±14.5)	35	507.5	0.85	0.03			7.25	0.28	7.6	0.30	5CUR40086A 5CUR40086C
00	073	4 (±0.5)	58 (±7.25)			18 (±1)	261 (±14.5)	35	507.5	0.85	0.03			7.25	0.28	7.6	0.30	5SCR400073A 5SCR400073M
00	020	4.3 (±0.5)	63.3 (±7.25)			15.2 (±1)	220.4 (±14.5)	35	507.5	0.85	0.03			7.25	0.28	7.6	0.30	5CUR40020A 5CUR40020B 5CUR40020C
00	004	4.9 (±0.5)	72.5 (±7.25)			18.9 (±1)	274 (±14.5)	35	507.5	0.85	0.03			7.25	0.28	7.6	0.30	5CUR40004A 5CUR40004C 5CUR40004M
00	017	5 (±0.5)	72.5 (±7.25)			12 (±1)	174 (±14.5)	35	507.5	0.85	0.03			7.25	0.28	7.6	0.30	5CUR40017A 5CUR40017C
00	028	5 (±1)	72.5 (±14.5)			21 (±1.5)	304.5 (±21.7)	35	507.5	0.85	0.03			7.25	0.28	7.6	0.30	5CUR40028A 5CUR40028B 5CUR40028C 5CUR40028M
00	071	5 (±1)	72.5 (±14.5)			17 (±1)	246.5 (±14.5)	35	507.5	1.35	0.05			6	0.23	7.3	0.29	5CUR40071A
00	075	5 (±0.5)	72.5 (±7.25)			15 (±1.5)	217.5 (±21.7)	35	507.5	0.85	0.03			7.25	0.28	7.6	0.30	5CUR40075A 5CUR40075B 5CUR40075C 5CUR40075E 5CUR40075M
00	104	5.5 (±1)	79.75 (±14.5)			17 (±1)	246.5 (±14.5)	35	507.5	0.85	0.03			3.1	0.12	3.5	0.14	5SCR400104A
00	115	5.5				28.5				0.85	0.03			5.6	0.22	6.1	0.24	5CUR40115M
00	001	5.8 (±1)	84.1 (±14.5)			22 (±2)	319 (±29)	35	507.5	1.55	0.06			7	0.27	7.5	0.29	5CUR40001A

List continues in the next page

Control curves with step

Curve description		Pressure						Stroke						CODE ⁽¹⁾				
Type	Nr	A		P		B		C		D		Q			E		F	
		bar (±toll)	psi (±toll)	bar (±toll)	psi (±toll)	bar (±toll)	psi (±toll)	bar	psi	mm	in	mm	in	mm	in	mm	in	
00	024	5.8 (±1)	84.1 (±14.5)			19 (±1.5)	275.5 (±21.7)	35	507.5	1.55	0.06			6.1	0.24	7.5	0.29	5CUR40024A 5CUR40024C
00	033	5.8 (±0.5)	84.1 (±7.25)			19 (±1)	275.5 (±14.5)	35	507.5	0.85	0.03			7.25	0.28	7.6	0.30	5CUR40033A 5CUR40033B 5CUR40033C 5CUR40033M
00	070	5.8 (±1)	84.1 (±14.5)			22.4 (±2)	324.8 (±29)	35	507.5	0.85	0.03			7.25	0.28	7.6	0.30	5CUR40070A 5CUR40070B 5CUR40070D 5CUR40070M
00	087	5.8 (±0.5)	84.1 (±7.25)			17 (±1.5)	246.5 (±21.7)	35	507.5	0.85	0.03			7.25	0.28	7.6	0.30	5CUR40087A
00	021	6 (±0.5)	87 (±7.25)			16.3 (±1)	236.4 (±14.5)	35	507.5	0.85	0.03			7.25	0.28	7.6	0.30	5CR400021A 5CR400021M
00	105	6 (±0.5)	87 (±7.25)			20 (±1)	290 (±14.5)	35	507.5	0.6	0.02			7.25	0.28	7.6	0.30	5CR400105B
00	054	6.2 (±1)	89.9 (±14.5)			24.5 (±2)	355.25 (±29)	35	507.5	0.85	0.03			7.25	0.28	7.6	0.30	5CUR40054A
00	007	6.5 (±1)	94.25 (±14.5)			36 (±2)	522 (±29)	35	507.5	0.85	0.03			7.25	0.28	7.6	0.30	5CR400007A
00	026	6.5 (±0.5)	94.25 (±7.25)			14 (±1)	203 (±14.5)	35	507.5	0.85	0.03			7.25	0.28	7.6	0.30	5CUR40026A 5CUR40026B 5CUR40026C
00	053	8 (±0.5)	116 (±7.25)			22.3 (±1)	323.3 (±14.5)	35	507.5	0.85	0.03			7.25	0.28	7.6	0.30	5CUR40053A
00	088	8 (±0.5)	116 (±7.25)			27 (±1.5)	391.5 (±21.7)	35	507.5	0.85	0.03			7.25	0.28	7.6	0.30	5CUR40088A 5CUR40088B 5CUR40088C 5CUR40088M
00	089	8 (±0.5)	116 (±7.25)			28 (±1)	406 (±14.5)	35	507.5	0.85	0.03			7.25	0.28	7.6	0.30	5CUR40089A 5CUR40089C 5CUR40089D 5CUR40089M
00	112	8 (±1.5)	116 (±21.7)			54 (±3.5)	783 (±50.75)	60	870	0.85	0.03			7.25	0.28	7.6	0.30	5CR400112A
00	122	10 (±1)	145 (±14.5)			27 (±2)	391.5 (±29)	35	507.5	0.85	0.03			7.25	0.28	7.6	0.30	5CR400122C
00	124	10 (±1)	145 (±14.5)			25 (±1.5)	362.5 (±21.7)	35	507.5	0.85	0.03			7.25	0.28	7.6	0.30	5CR400124A
00	036	12 (±0.5)	174 (±7.25)			25 (±1)	362.5 (±14.5)	35	507.5	0.85	0.03			7.25	0.28	7.6	0.30	5CUR40036A
00	107	12 (±1)	174 (±14.5)			20 (±1)	290 (±14.5)	35	507.5	0.85	0.03			7.25	0.28	7.6	0.30	5CR400107A
00	012	14 (±1)	203 (±14.5)			28.5 (±1.5)	413.25 (±21.7)	35	507.5	0.85	0.03			7.25	0.28	7.6	0.30	5CR400012A
00	038	22 (±2)	319 (±29)			37 (±3)	536.5 (±43.5)	35	507.5	0.85	0.03			7.25	0.28	7.6	0.30	5CUR40038C 5CUR40038M
With Pre-feeling for electromagnetic detent																		
E0	063	1.4 (±0.5)	20.3 (±7.25)	11.5 (±1)	166.75 (±14.5)	12.8 (±1)	185.6 (±14.5)	35	507.5	0.85	0.03	6.5	0.25	7.25	0.28	7.6	0.30	5CUR4E063M
E0	046	2 (±0.5)	29 (±7.25)	13 (±1)	188.5 (±14.5)	14.5 (±1)	210.2 (±14.5)	35	507.5	0.85	0.03	6.5	0.25	7.25	0.28	7.6	0.30	5CUR4E046M
E0	096	3.5 (±0.5)	50.7 (±7.25)	15 (±0.5)	217.5 (±7.25)	16.5 (±1)	239.2 (±14.5)	35	507.5	0.85	0.03	6.5	0.25	7.25	0.28	7.6	0.30	5CR4E0096B
E0	009	3.5 (±0.5)	50.7 (±7.25)	13.7 (±1)	198.65 (±14.5)	15.1 (±1)	219 (±14.5)	35	507.5	0.85	0.03	6.5	0.25	7.25	0.28	7.6	0.30	5CUR4E009A 5CUR4E009M
E0	073	4 (±0.5)	58 (±7.25)	18 (±1)	261 (±14.5)	19.9 (±1)	288.55 (±14.5)	35	507.5	0.85	0.03	6.5	0.25	7.25	0.28	7.6	0.30	5CR4E0073A
E0	086	4 (±0.5)	58 (±7.25)	16.5 (±0.8)	239.3 (±11.6)	18.2 (±1)	263.9 (±14.5)	30	435	0.85	0.03	6.5	0.25	7.25	0.28	7.6	0.30	5CUR4E086A 5CUR4E086M
E0	094	4 (±0.5)	58 (±7.25)	12.7 (±0.5)	184.1 (±7.25)	13.8 (±1)	200.1 (±14.5)	35	507.5	0.85	0.03	6.5	0.25	7.25	0.28	7.6	0.30	5CUR4E094M 5CUR4E094B
E0	075	5 (±0.5)	72.5 (±7.25)	15 (±1)	217.5 (±14.5)	16.3 (±1.5)	236.35 (±21.7)	35	507.5	0.85	0.03	6.5	0.25	7.25	0.28	7.6	0.30	5CUR4E075A 5CUR4E075M
E0	033	5.8 (±0.5)	84.1 (±7.25)	19 (±1)	275.5 (±14.5)	20.8 (±1.5)	301.6 (±21.7)	35	507.5	0.85	0.03	6.5	0.25	7.25	0.28	7.6	0.30	5CUR4E033B 5CUR4E033M
E0	087	5.8 (±0.5)	84.1 (±7.25)	17.8 (±1)	258.1 (±14.5)	19.4 (±1)	281.3 (±14.5)	35	507.5	0.85	0.03	6.5	0.25	7.25	0.28	7.6	0.30	5CUR4E087M
E0	085	6 (±1)	87 (±14.5)	25 (±2)	362.5 (±29)	27.5 (±2)	398.75 (±29)	35	507.5	0.85	0.03	6.5	0.25	7.25	0.28	7.6	0.30	5CR4E0085M
E0	088	8 (±0.5)	116 (±7.25)	27 (±1)	391.5 (±14.5)	29.5 (±1)	427.75 (±14.5)	35	507.5	0.85	0.03	6.5	0.25	7.25	0.28	7.6	0.30	5CUR4E088M

⁽¹⁾ Codes are referred to the curve with the specific return spring
For different curves please contact our Sales Department

Control curves without step

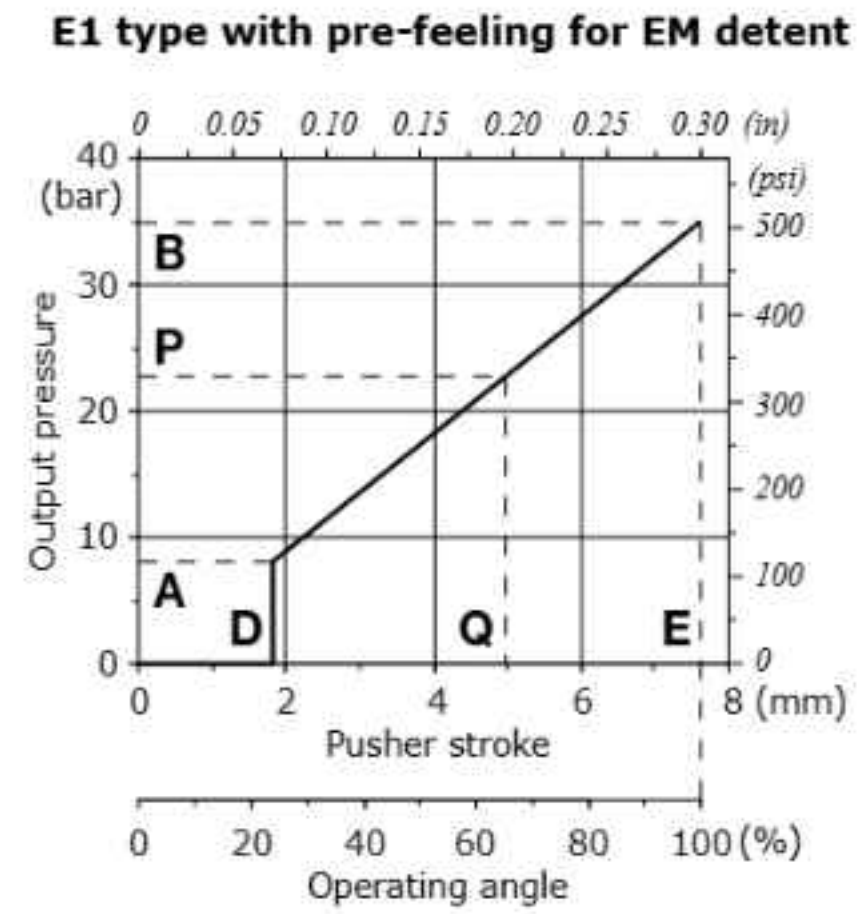
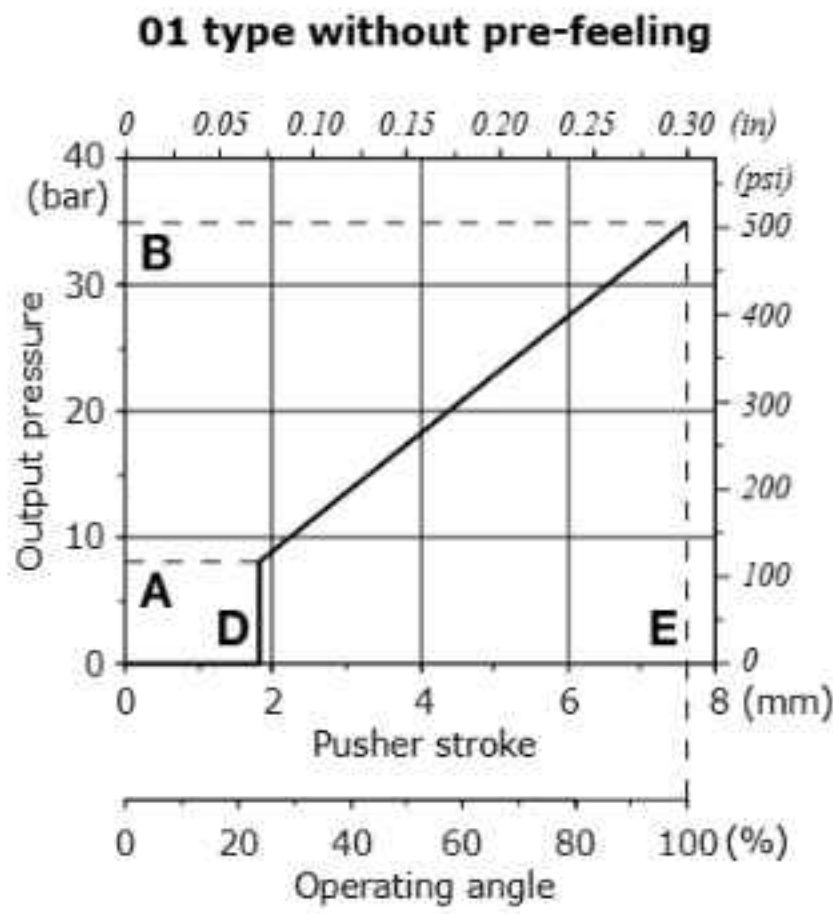

Curve description		Pressure						Stroke						CODE ⁽¹⁾
Type	Nr	A		P		B		D		Q		E		
		bar (±tol)	psi (±tol)	bar (±tol)	psi (±tol)	bar (±tol)	psi (±tol)	mm	in	mm	in	mm	in	
Without pre-feeling														
01	148	0 (+0.5)	0 (±7.25)			13 (±1)	188.5 (±14.5)	0.85	0.03			7.6	0.30	5CUR40148B
01	151	0 (+1)	0 (+14.5)			41 (±2)	594.5 (±29)	1	0.04			5.4	0.21	5CR401151C
01	099	1 (±0.5)	14.5 (±7.25)			20 (±1.5)	290 (±21.7)	1.55	0.06			7.5	0.29	5CR401099A
01	131	1 (±1)	14.5 (±14.5)			15 (±1)	217.5 (±14.5)	0.85	0.03			7.6	0.30	5CUR40131A 5CUR40131C
01	100	1.2 (±0.5)	17.4 (±7.25)			18.9 (±1)	274 (±14.5)	0.85	0.03			7.6	0.30	5CUR40100B 5CUR40100M
01	163	1.4 (±0.5)	20.3 (±7.25)			11.5 (±1)	166.8 (±14.5)	0.85	0.03			7.6	0.30	5CUR40163A 5CUR40163M
01	105	2 (±0.5)	29 (±7.25)			8 (±1)	116 (±14.5)	0.85	0.03			7.6	0.30	5CUR40105A
01	129	2 (±0.5)	29 (±7.25)			66 (±4)	957 (±58)	0.85	0.03			6.8	0.28	5CUR40129A
01	154	2 (±0.5)	29 (±7.25)			15 (±1)	217.5 (±14.5)	0.85	0.03			7.6	0.30	5CUR40154A 5CUR40154M
01	138	2.5 (±0.5)	36.2 (±7.25)			13 (±1)	188.5 (±14.5)	0.85	0.03			7.6	0.30	5CUR40138A
01	143	3 (±0.5)	43.5 (±7.25)			25 (±1)	362.5 (±14.5)	0.85	0.03			7.6	0.30	5CUR40143A
01	127	3.4 (±0.5)	49.3 (±7.25)			12 (±1)	174 (±14.5)	0.85	0.03			7.6	0.30	5CUR40127A 5CUR40127B
01	157	3.4 (±1)	49.3 (±14.5)			17.2 (±1)	249.4 (±14.5)	0.85	0.03			7.6	0.30	5CUR40157A 5CUR40157B
01	114	4 (±0.5)	58 (±7.25)			10 (±1)	145 (±14.5)	0.85	0.03			7.6	0.30	5CUR40114A 5CUR40114B 5CUR40114M
01	126	4.5 (±0.7)	65.2 (±10.1)			30.7 (±1.5)	445.1 (±21.7)	0.85	0.03			7.6	0.30	5CUR40126A
01	170	5 (±0.5)	72.5 (±7.25)			20 (±1)	290 (±14.5)	0.85	0.03			7.6	0.30	5CUR40170A 5CUR40170M
01	175	5 (±0.5)	72.5 (±7.25)			16 (±1.5)	232 (±21.7)	0.85	0.03			7.6	0.30	5CUR40175A 5CUR40175D
01	111	5.5 (±0.5)	88 (±7.25)			25.5 (±1)	370 (±14.5)	0.85	0.03			7.6	0.30	5CUR40111A 5CUR40111B 5CUR40111C
01	118	5.8 (±1)	84.1 (±14.5)			19.5 (±1.5)	282.7 (±21.7)	1.55	0.06			7.5	0.29	5CUR40118A
01	135	5.8 (±0.5)	84.1 (±7.25)			23 (±1.5)	333.5 (±21.7)	0.85	0.03			7.6	0.30	5CUR40135A 5CUR40135M
01	167	6 (±0.5)	87 (±7.25)			18 (±1)	261 (±14.5)	0.85	0.03			7.6	0.30	5CUR40167M
01	103	6 (±1)	87 (±14.5)			30 (±2.5)	435 (±36.2)	0.85	0.03			7.6	0.30	5CUR40103A 5CUR40103M
01	106	6 (±1)	87 (±14.5)			40 (±2)	580 (±29)	0.85	0.03			7.6	0.30	5CUR40106A 5CUR40106B 5CUR40106C
01	095	6.5 (±0.5)	94.25 (±7.25)			17.8 (±1)	258.1 (±14.5)	0.85	0.03			7.6	0.30	5CR401095A
01	125	8 (±0.5)	116 (±7.25)			22.5 (±1)	326.25 (±14.5)	0.85	0.03			7.6	0.30	5CUR40125M

List continues in the next page

Control curves without step

Curve description		Pressure						Stroke						CODE ⁽¹⁾
Type	Nr	A		P		B		D		Q		E		
		bar (\pm toll)	psi (\pm toll)	bar (\pm toll)	psi (\pm toll)	bar (\pm toll)	psi (\pm toll)	mm	in	mm	in	mm	in	
01	115	8.3 (\pm 0.7)	120.3 (\pm 10.1)			22.5 (\pm 1)	326.2 (\pm 14.5)	0.85	0.03			7.6	0.30	5CUR40115M
01	159	10 (\pm 0.5)	145 (\pm 7.25)			28 (\pm 1)	406 (\pm 14.5)	0.85	0.03			7.6	0.30	5CUR401159A
01	090	12 (\pm 1)	174 (\pm 14.5)			18 (\pm 1)	261 (\pm 14.5)	0.85	0.03			7.6	0.30	5CR401090A
01	195	14 (\pm 1)	203 (\pm 14.5)			29.5 (\pm 1.5)	427.75 (\pm 21.7)	0.85	0.03			7.6	0.30	5CR401195A
01	144	35 (\pm 2)	507.5 (\pm 29)			70 (\pm 3.5)	1015 (\pm 50.7)	0.85	0.03			7.6	0.30	5CUR40144C
With Pre-feeling for electromagnetic detent														
E1	103	6 (\pm 1)	87 (\pm 14.5)	30 (\pm 1.5)	435 (\pm 21.7)	34.7 (\pm 2)	503.1 (\pm 29)	0.85	0.03	6.5	0.25	7.6	0.30	5CUR4E103M
E1	156	3.4 (\pm 0.5)	46.3 (\pm 7.25)	14.5 (\pm 1)	210.25 (\pm 14.5)	16.7 (\pm 1)	242.15 (\pm 14.5)	0.85	0.03	6.5	0.25	7.6	0.30	5CUR4E156M

⁽¹⁾ Codes are referred to the curve with the specific return spring
For different curves please contact our Sales Department

Control curves piecewise with and without step

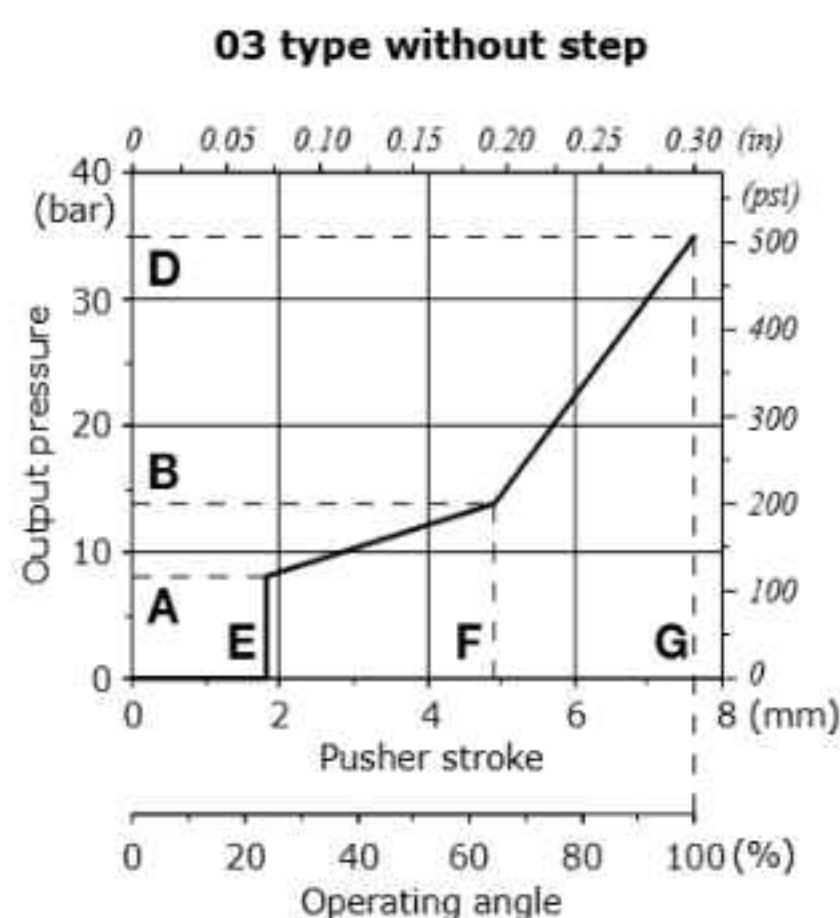
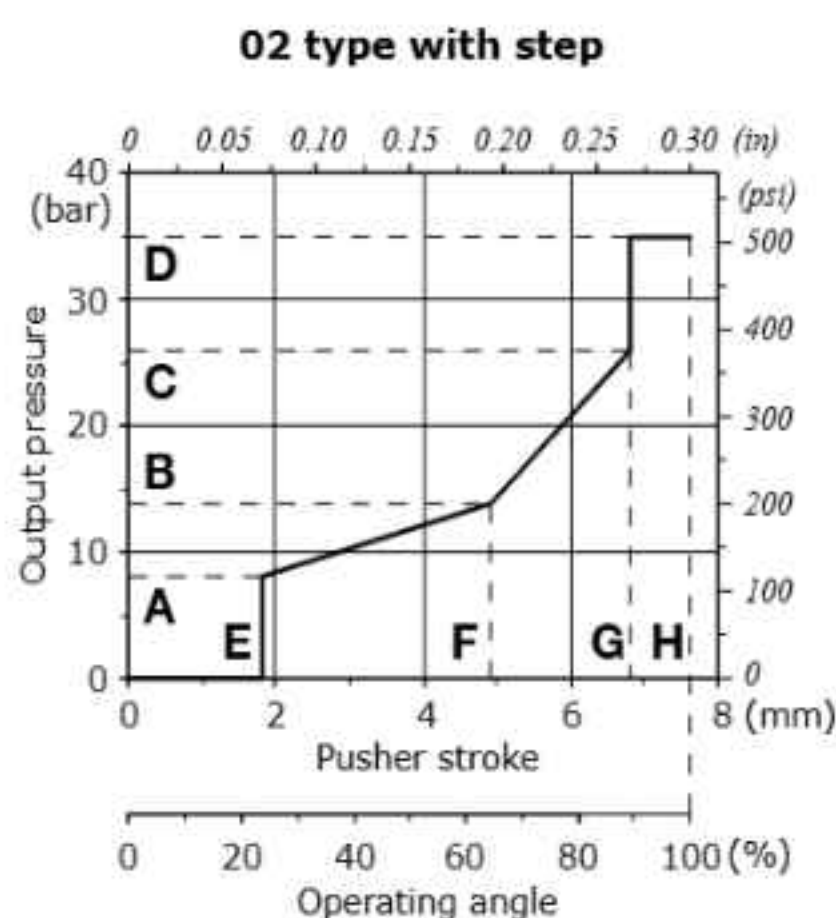

Control curve with step

Curve description		Pressure						Stroke								CODE ⁽¹⁾		
Type	Nr	A		B		C		D		E		F		G			H	
		bar (\pm toll)	psi (\pm toll)	bar (\pm toll)	psi (\pm toll)	bar (\pm toll)	psi (\pm toll)	bar	psi	mm	in	mm	in	mm	in	mm	in	
02	210	1.5 (\pm 1)	21.7 (\pm 14.5)	7 (\pm 1)	101.5 (\pm 14.5)	15 (\pm 1)	217.5 (\pm 14.5)	35	507.5	0.85	0.03	5.7	0.22	7.25	0.28	7.6	0.30	5CUR40210C
02	204	4.3 (\pm 0.5)	62.3 (\pm 7.25)	12 (\pm 0.8)	174 (\pm 11.6)	20.5 (\pm 1)	297.2 (\pm 14.5)	35	507.5	0.85	0.03	5.7	0.22	7.25	0.28	7.6	0.30	5CUR40204C
02	200	7 (\pm 1)	101.5 (\pm 14.5)	13 (\pm 1)	188.5 (\pm 14.5)	22 (\pm 1)	319 (\pm 14.5)	30	435	0.85	0.03	5.7	0.22	7.25	0.28	7.6	0.30	5CUR40200A 5CUR40200M

Control curve without step

Curve description		Pressure						Stroke						CODE ⁽¹⁾
Type	Nr	A		B		D		E		F		G		
		bar (\pm toll)	psi (\pm toll)	bar (\pm toll)	psi (\pm toll)	bar	psi	mm	in	mm	in	mm	in	
03	311	1.2 (\pm 0.5)	17.4 (\pm 7.25)	14.7 (\pm 2.5)	213.15 (\pm 36.25)	22 (\pm 2)	319 (\pm 29)	0.85	0.03	6.6	0.26	7.6	0.30	5CUR40311B
03	300	5.1 (\pm 0.5)	73.95 (\pm 7.25)	16 (\pm 1.5)	232 (\pm 21.75)	20 (\pm 2)	290 (\pm 29)	0.85	0.03	6.6	0.26	7.6	0.30	5CUR40300A
03	302	6 (+0.5/-1.5)	87 (+7.25/-21.75)	12 (\pm 1)	175 (\pm 14.5)	22 (+2)	320 (+29)	0.85	0.03	6.6	0.26	7.6	0.30	5CUR40302A 5CUR40302C 5CUR40302D

⁽¹⁾ Codes are referred to the curve with the specific return spring
For different curves please contact our Sales Department

Ordering codes

SVM405 / 3 1 - B / 01 S108 (90) - 045(TM1M) - 0 0 089N M X 4 - <CRVN>



Body is painted as standard, with one coat of primer black antirust paint.

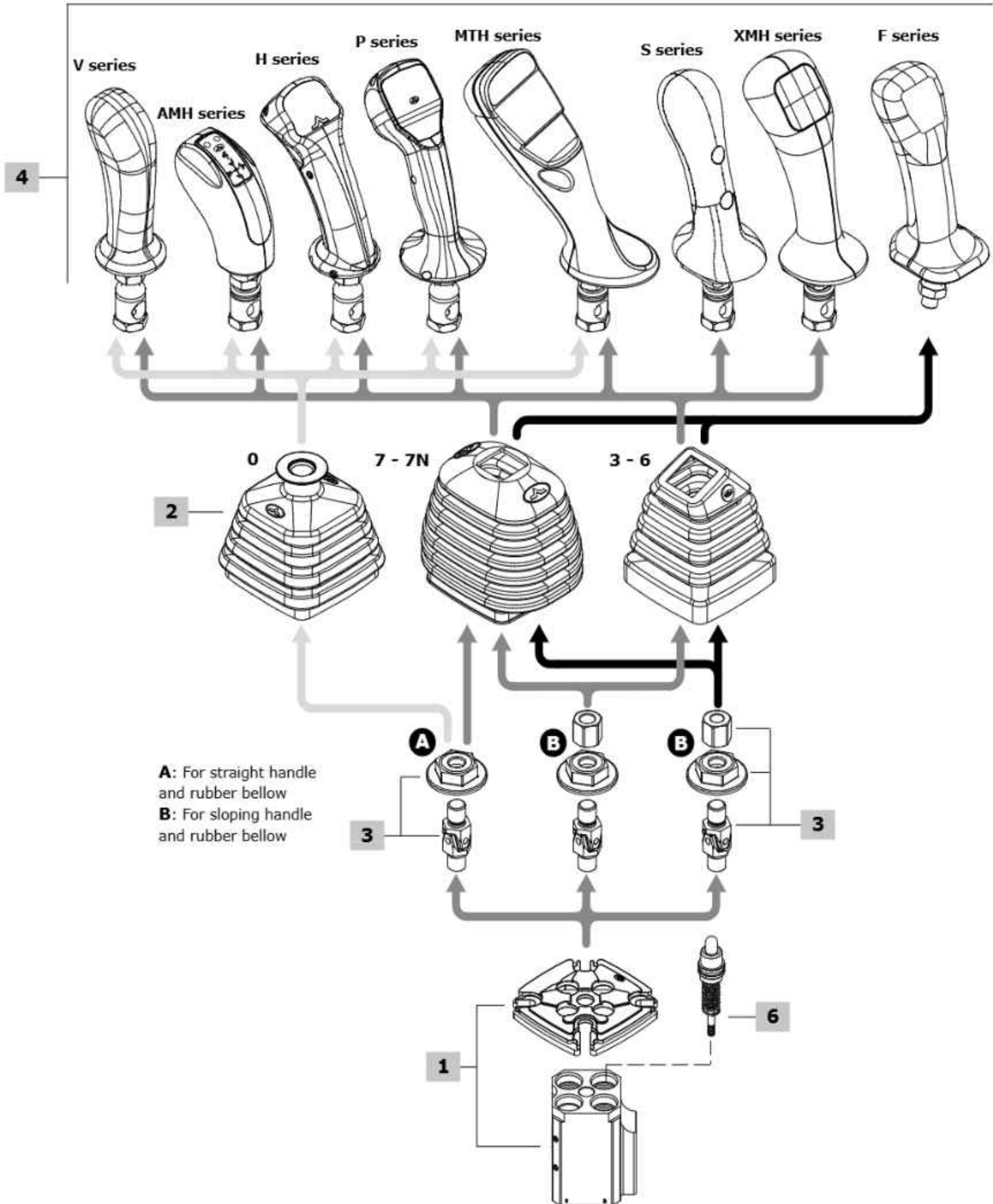

1 Body kit *

TYPE	CODE	DESCRIPTION
SVM405/1A-B	5CO3420309	For rubber bellow square base

2 Rubber bellow

TYPE	CODE	DESCRIPTION
0	3SOF111130	Straight type, square base with logo: not available for type S and F
3	3SOF111113	Sloping type, square base with logo; only for 9° sloping handles. Not available for type 16 control
6	3SOF111114	As type 3 without logo. Not available for type 16 control
7	3SOF111135	General purpose type with logo; it can be used straight or up to 30° sloping in all directions
7N	3SOF111137	As type 7 without logo.

3 Control option

TYPE	CODE	DESCRIPTION
Spring return in neutral position		
01	5CIN4003	For handles with straight rubber bellow (not available for 10 and F series)
	5CIN4001	For handles with sloping rubber bellow (not available for 10 and S series)
01F	5CIN401F00	For F series handles
With microswitches for movement detection on each port. It needs type 7 rubber bellow and special body; please contact our Sales Department.		
16	5CIN4023	For handles with straight rubber bellow (not available for 10 and F series)
	5CIN4021	For handles with sloping rubber bellow (not available for 10 and S series)

6 Pressure control curves

For list available see from page 35

6.1 Curve type

TYPE	DESCRIPTION
0	Standard

6.2 Typology of curves

TYPE	DESCRIPTION
0	With step
1	Without step

6.3 Curve identification

Progressive number

6.4 Return springs

TYPE	DESCRIPTION
M	Operation range from 18 to 25.5 N - from 4.04 to 5.73 lbf
A	Operation range from 23 to 35.2 N - from 5.17 to 7.91 lbf
B	Operation range from 23 to 68.1 N - from 5.17 to 15.31 lbf
C	Operation range from 89 to 176 N - from 20 to 39.56 lbf
D	Operation range from 110 to 220 N - from 24.73 to 49.46 lbf
E	Operation range from 137.8 to 276.1 N - from 31 to 62.07 lbf

4 Handles

Some handles as examples are listed below: for technical specifications and full range of handles and other types of joint see the "Handles and hand levers" catalogue.

V series handle

TYPE: **V007-(Q)** CODE: 5IMP030071
DESCRIPTION: Without switches, with sloping 19° left joint and square seat bellow adapter

AMH series handle

TYPE: **AMHT030008-(Q)-6N2D035-7R2D035-8N2D035-(E1)**
CODE: 2IM3000007

DESCRIPTION: 3 spring return push-buttons, flying leads, sloping 19° right joint and square seat bellow adapter

H series handle

TYPE: **HMB03G-(Q)-1R4040-4R3040-5R2040-(12VDC)**
CODE: 2IM4600051

DESCRIPTION: 3 spring return push-buttons on the operator side, flying leads, straight joint, for circular seat bellow

P series handle

TYPE: **PZMA1200B7-0R035-3Y2D035-WN130035-ZN130035-(SCHEDA 2PWM)-(TD2M)** CODE: 2IM8700003

DESCRIZIONE: 2 proportional roller and 1 spring return push-button on operator side, "dead man" switch, flying leads with Deutsch pins, sloping 19° left joint and square seat bellow adapter

MTH series handle

TYPE: **MTH-R00-ZTI4100(K)Y-00-1Y2035-2Y2035-3N2035-6N2035-ZN122035-MRZ035-(5VDC)-D2F12**

CODE: 2IM2000005

DESCRIPTION: 1 proportional roller and 4 spring return push-buttons on the operator side, 1 FNR rocker switch on the opposite side, Deutsch connector, sloping 9° left joint and square seat bellow adapter

XMH series handle

TYPE: **XMHZTA21008-2G2035-4G2035-7G2035-VG171035**
CODE: 2IM1000004

DESCRIPTION: 1 proportional roller and 2 spring return push-buttons on the operator side, 1 push button with spring return on the opposite side, Deutsch connector, 19° sloping right joint, for square seat bellow

S series handle

TYPE: **SZTA8-0G4045-XG122045** CODE: 2IM5310003

DESCRIPTION: With proportional roller on the operator side and spring return push-button on the opposite side, 19° sloping right joint, for square seat bellow

F series handle

TYPE: **F02F-02R(1=8)** CODE: 320000251

DESCRIPTION: 2 microswitch push-buttons on the operator side and 2 on the opposite side, flying leads, 15° sloping joint, square seat bellow adapter, requires dedicated control

5 Handle position

TYPE	DESCRIPTION
(-)	STANDARD configuration, cable operation on work port 4: omitted in description
(90)	Mounted with 90° rotation step: forward operation towards port 1
(180)	Mounted with 180° rotation step: forward operation towards port 2
(270)	Mounted with 270° rotation step: forward operation towards port 3

NOTE (*) - Codes are referred to **BSP** thread.

Configuration option

Handle options

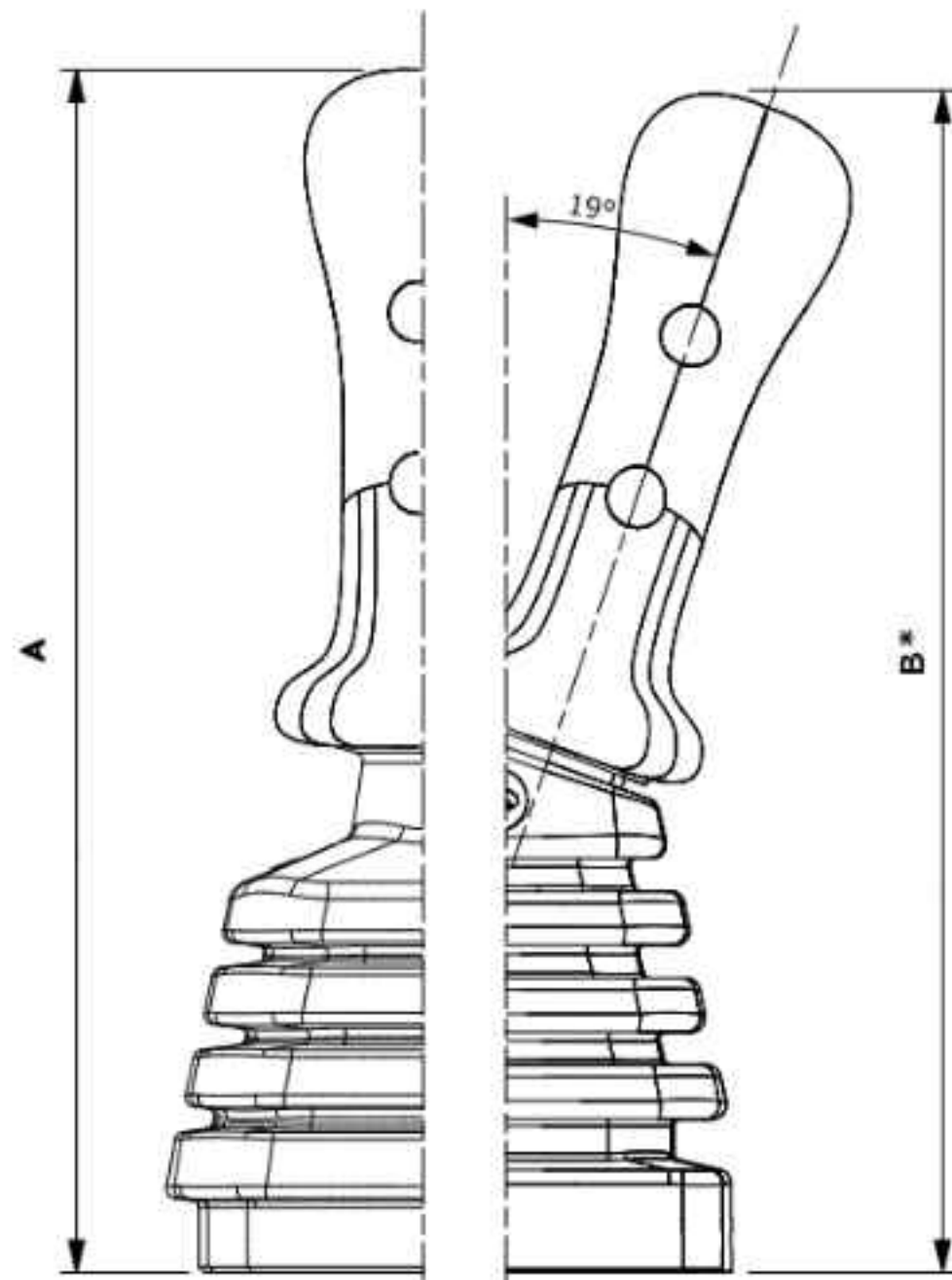

Handle positions

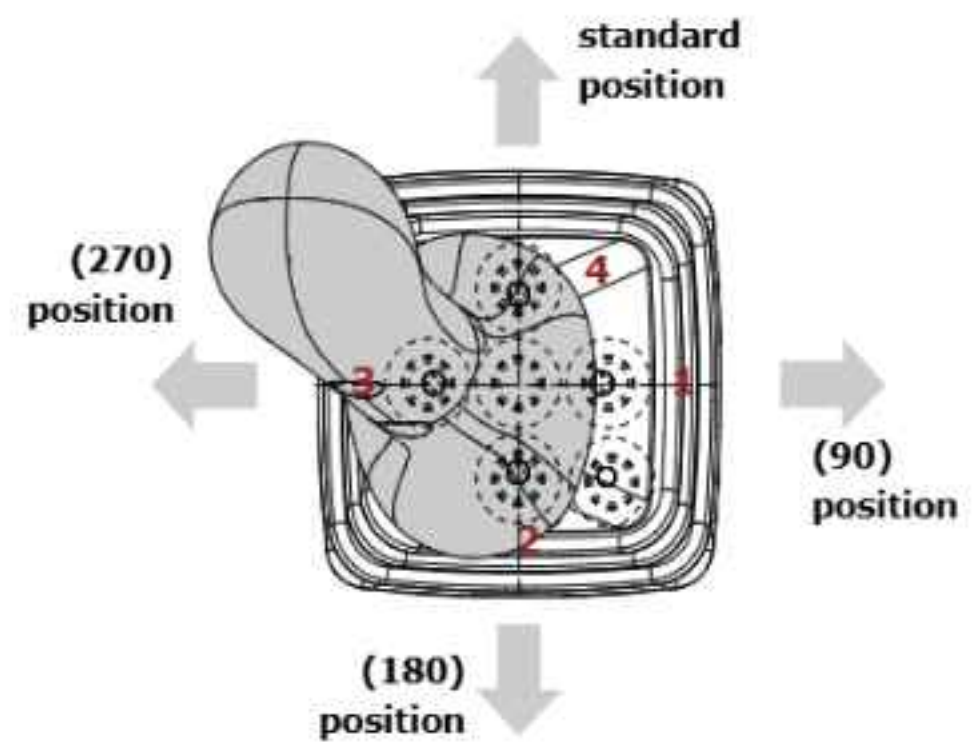

Type	A*		B*	
	mm	in	mm	in
Serie V	242	9.53	235.5	9.27
Serie AMH	193	7.60	195	7.68
Serie H	235	9.25	233	9.17
Serie P	254	10	252	9.92
Serie MTH	261	10.28	249	9.80
Serie S	250	9.84	247	9.72
Serie XMH	259	10.20	255	10.04
Serie F	241	9.49	237	9.33

(*) The overall dimensions are indicative

Control curves with and without step

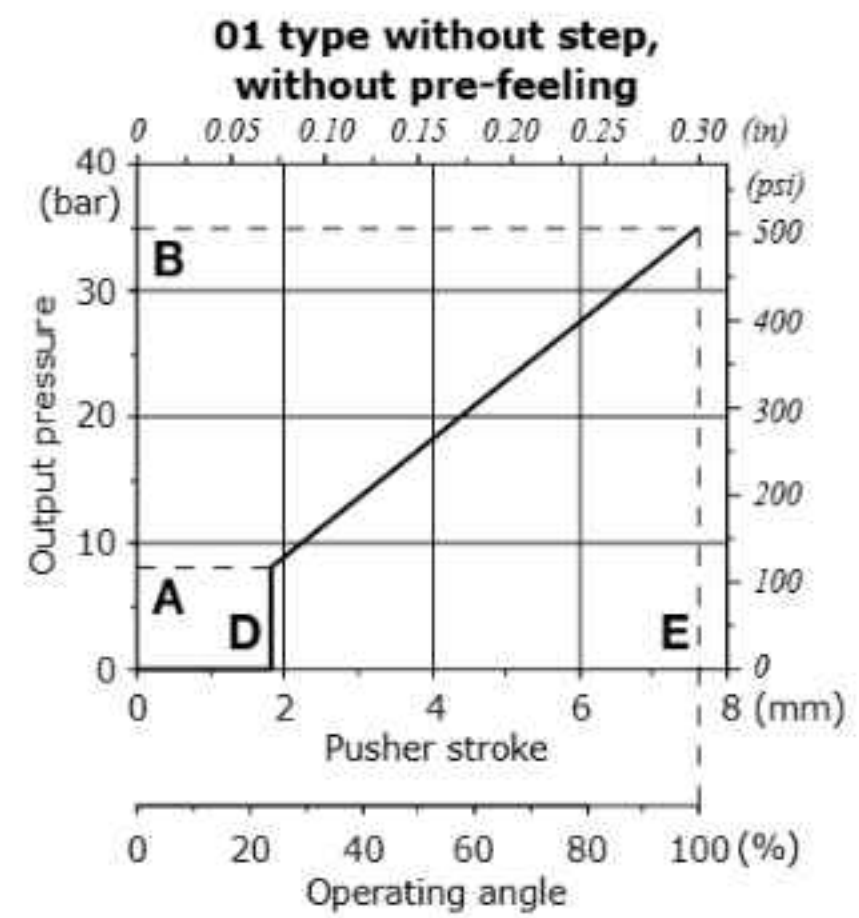
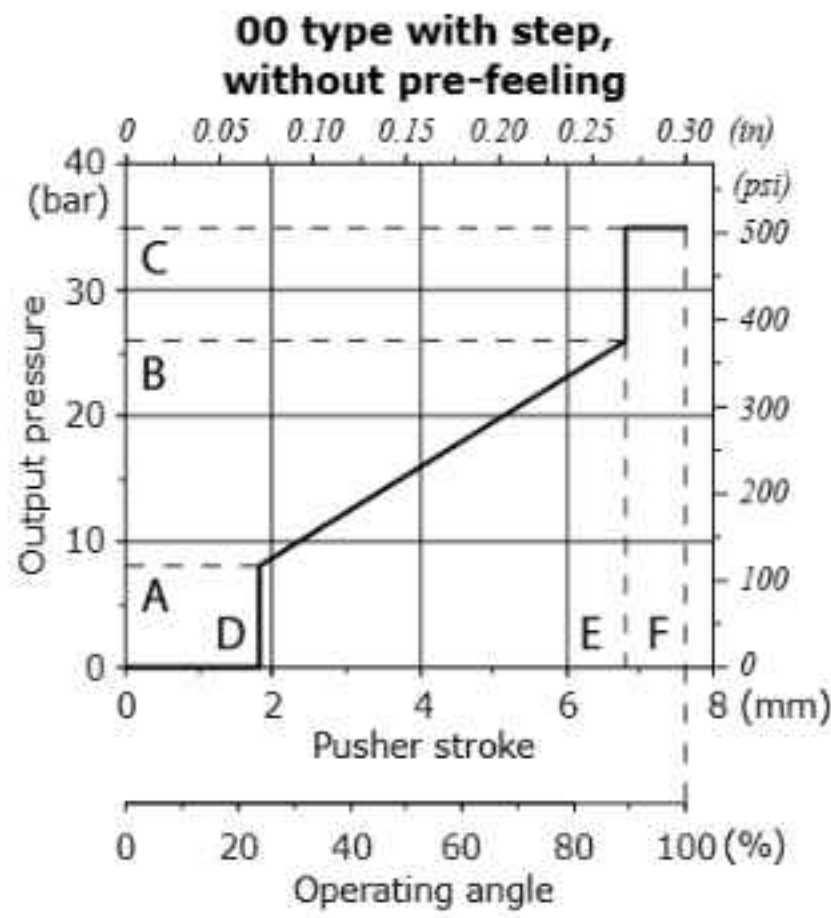

With step

Curve description		Pressure						Stroke						CODE ⁽¹⁾
Type	Nr	A		B		C		D		E		F		
		bar (±tol)	psi (±tol)	bar (±tol)	psi (±tol)	bar	psi	mm	in	mm	in	mm	in	
00	073	4 (±1)	58 (±14.5)	18 (±1)	261 (±14.5)	35	507.5	0.85	0.03	7.25	0.28	7.6	0.30	5CR400073NB 5CR010073NM
00	020	4.3 (±0.5)	62.35 (±7.25)	15.2 (±1)	220.4 (±14.5)	35	507.5	0.85	0.03	7.25	0.28	7.6	0.30	5CR400020NM
00	004	4.9 (±0.5)	71.05 (±7.25)	18.9 (±1)	274.05 (±14.5)	35	507.5	0.85	0.03	7.25	0.28	7.6	0.30	5CR400004NM
00	075	5 (±0.5)	72.5 (±7.25)	15 (±1.5)	217.5 (±21.75)	35	507.5	0.85	0.03	7.25	0.28	7.6	0.30	5CR400075NA 5CR400075NM
00	028	5 (±1)	72.5 (±14.5)	21 (±1.5)	304.5 (±21.75)	35	507.5	0.85	0.03	7.25	0.28	7.6	0.30	5CR400028NM
00	087	5.8 (±0.5)	84.1 (±7.25)	17 (±1.5)	246.5 (±21.75)	35	507.5	0.85	0.03	7.25	0.28	7.6	0.30	5CR400087NM
00	033	5.8 (±0.5)	84.1 (±7.25)	19 (±1)	275.5 (±14.5)	35	507.5	0.85	0.03	7.25	0.28	7.6	0.30	5CR400033NA 5CR400033NM
00	070	5.8 (±1)	84.1 (±14.5)	22.4 (±2)	324.8 (±29)	35	507.5	0.85	0.03	7.25	0.28	7.6	0.30	5CR400070NM
00	021	6 (±0.5)	87 (±7.25)	16.3 (±1)	236.35 (±14.5)	35	507.5	0.85	0.03	7.25	0.28	7.6	0.30	5CR400021NM
00	054	6.2 (±1)	89.9 (±14.5)	24.5 (±2)	355.25 (±29)	35	507.5	0.85	0.03	7.25	0.28	7.6	0.30	5CR400054NM
00	026	6.5 (±0.5)	94.25 (±7.25)	14 (±1)	203 (±14.5)	35	507.5	0.85	0.03	7.25	0.28	7.6	0.30	5CR400026NM
00	123	6.5 (±0.5)	94.25 (±7.25)	15.7 (±0.5)	227.65 (±7.25)	35	507.5	0.85	0.03	7.25	0.28	7.6	0.30	5CR400123NB
00	098	7 (±0.5)	101.5 (±7.25)	22.6 (±1.5)	327.7 (±21.75)	35	507.5	0.85	0.03	7.25	0.28	7.6	0.30	5CR400098NM
00	088	8 (±0.5)	116 (±7.25)	27 (±1.5)	391.5 (±21.75)	35	507.5	0.85	0.03	7.25	0.28	7.6	0.30	5CR400088NM
00	089	8 (±0.5)	116 (±7.25)	28 (±1)	406 (±14.5)	35	507.5	0.85	0.03	7.25	0.28	7.6	0.30	5CR400089NA 5CR400089NM

⁽¹⁾ Codes are referred to the curve with the specific return spring
For different curves please contact our Sales Department

Without step

Curve description		Pressure				Stroke				CODE ⁽²⁾
Tipo	Nr	A		B		D		E		
		bar (±tol)	psi (±tol)	bar (±tol)	psi (±tol)	mm	in	mm	in	
01	156	3.4 (±0.5)	49.3 (±7.25)	14.5 (±1.5)	210.25 (±21.75)	0.85	0.03	7.6	0.30	5CUR40156NM
01	111	5.5 (±1)	79.75 (±14.5)	25.5 (±2)	369.75 (±29)	0.85	0.03	7.6	0.30	5CUR40111NA

⁽²⁾ Codes are referred to the curve with the specific return spring
For different curves please contact our Sales Department

Dimensions and hydraulic circuit

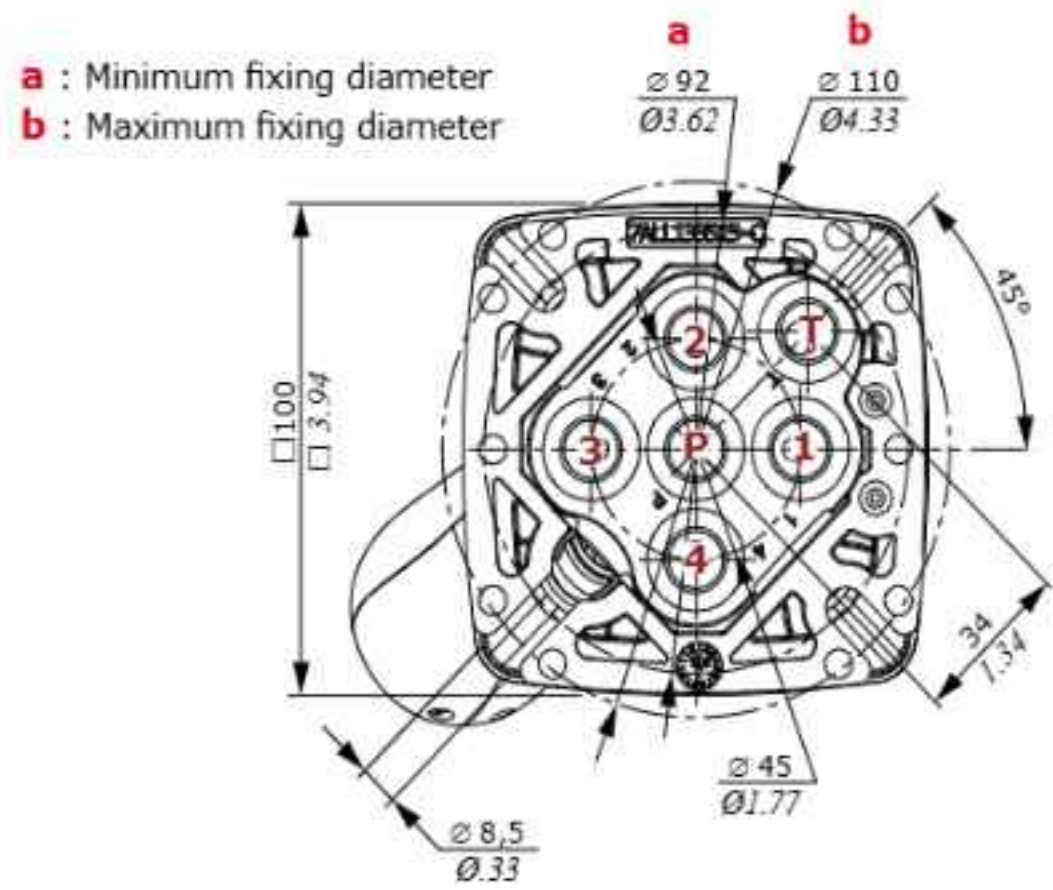

NOTE: normally the pilot control valve is supplied with the handle oriented towards port nr. 4 (see page 28)

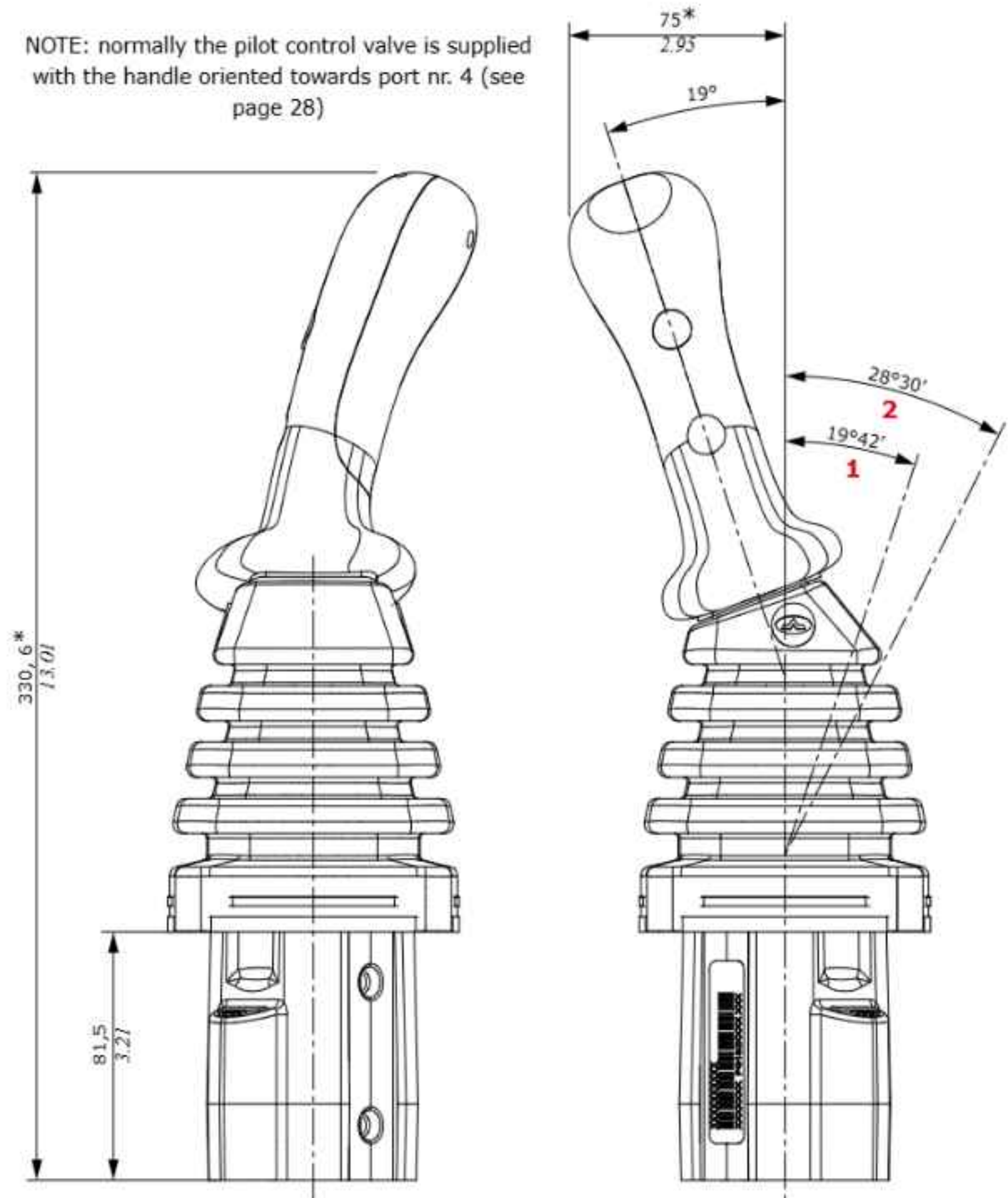
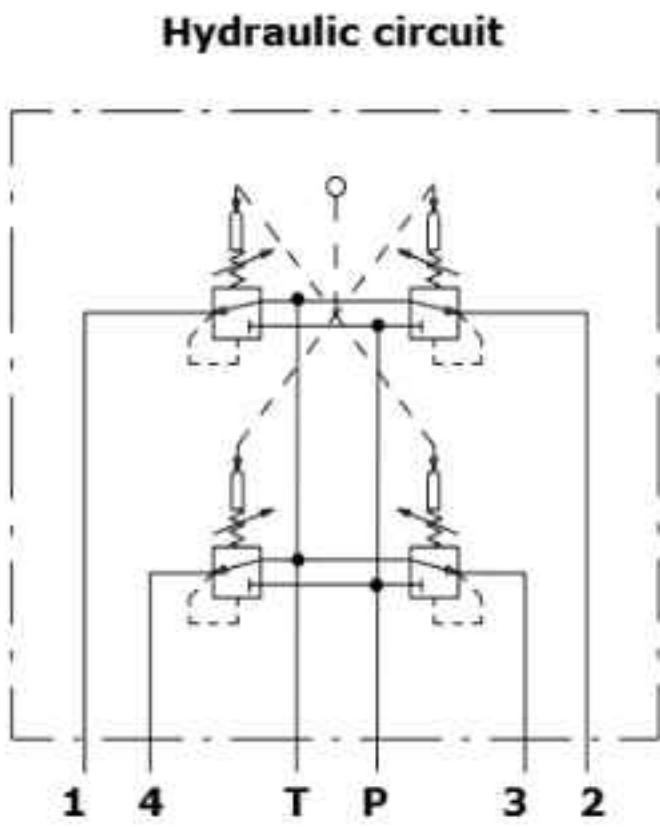

(*) S type handle

1 : Single work port
2 : Two simultaneous work ports

Ordering codes

SVM320 / 3 1 - B / 01 S108 (90) - 045(TM1M) - 0 0 089C M X 4 - <CRVN>



Body is painted as standard, with one coat of primer black antirust paint

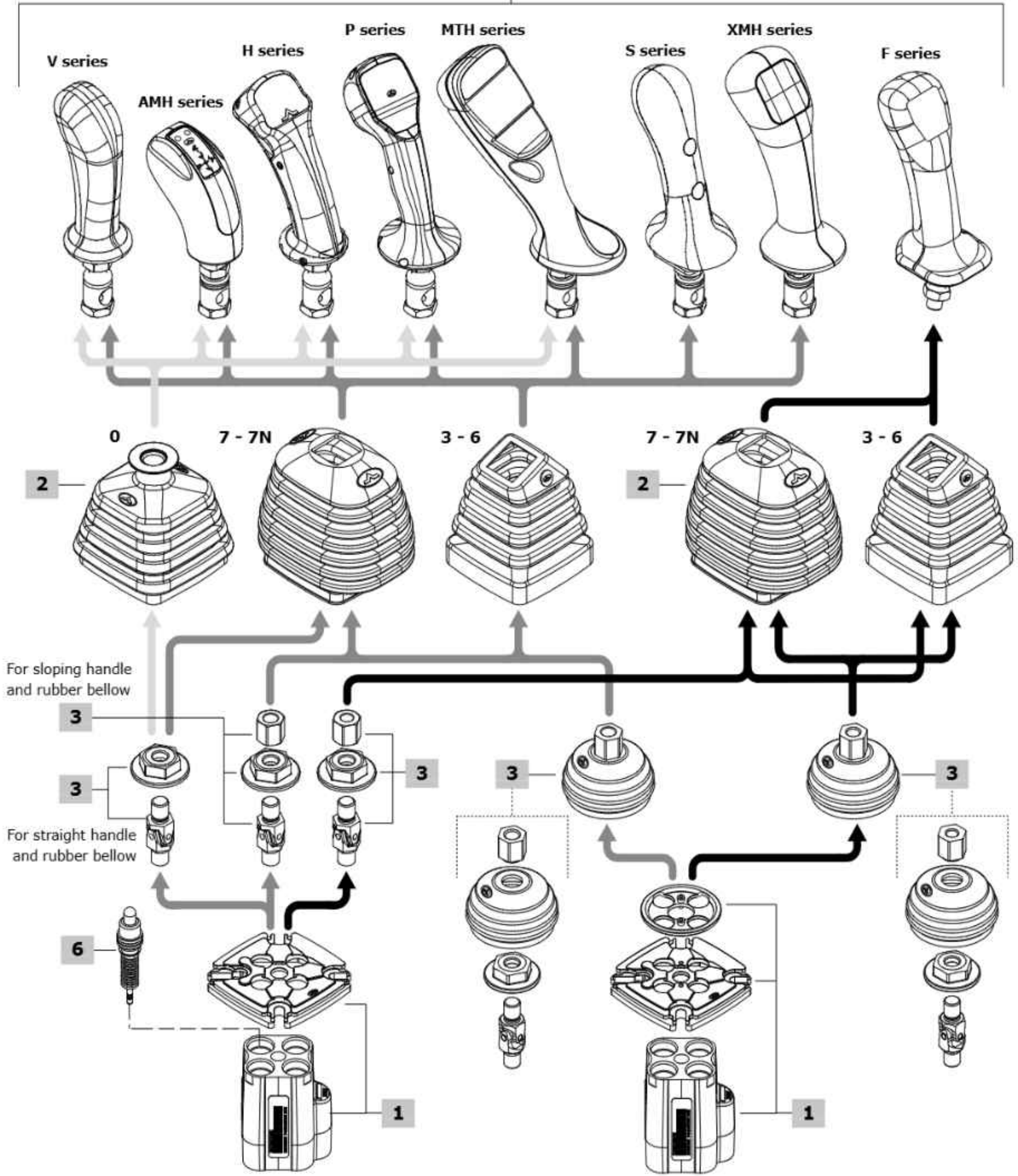

Ordering codes

1 Body kit*

TYPE	CODE	DESCRIPTION
SVM320/1-B	5CO3320300	Body kit with cast iron body.
SVM320/1-B	5CO3320300C	As previous one, double rubber bellow arrangement

2 Rubber bellow

TYPE	CODE	DESCRIPTION
For single bellow		
0	3SOF111130	Straight type, square base with logo: not available for and F type handles
3	3SOF111113	Sloping type, square base with logo; only for 19° sloping handles
6	3SOF111114	As previous one, without logo
7	3SOF111135	Universal type, rectangular base, with logo. It can be used straight and 30° sloping in all directions
7N	3SOF111137	As previous one, without logo
For double bellow		
7N	3SOF111137	As previous one, without logo

3 Control option

TYPE	CODE	DESCRIPTION
Spring return in neutral position		
01	5CIN4003	For V, AMH, H, P MTH series handles with straight rubber bellow
	5CIN4001	For handles with sloping (3-6) or tilting (7-7N) rubber bellow
01F	5CIN401F00	As type 01 for F type handle
01SC	5CIN4050	With additional protective rubber bellow. Available for handles with sloping(3-6) or tilting (7-7N) rubber bellow Dedicated body kit is required Not available for F type handle
01SCF	5CIN405F00	As previous one for F type handle

6 Pressure control curves

For list available see from page 40

6.1 Curve type

TYPE	DESCRIPTION
0	Standard

6.2 Typology of curves

TYPE	DESCRIPTION
0	With step
1	Without step

6.3 Curve identification

Progressive number

6.4 Return springs

TYPE	DESCRIPTION
M	Operation range from 18 to 25.5 N - <i>from 4.04 to 5.73 lbf</i>
A	Operation range from 23 to 35.2 N - <i>from 5.17 to 7.91 lbf</i>
B	Operation range from 23 to 68.1 N - <i>from 5.17 to 15.31 lbf</i>
C	Operation range from 89 to 176 N - <i>from 20 to 39.56 lbf</i>
D	Operation range from 110 to 220 N - <i>from 24.73 to 49.46 lbf</i>
E	Operation range from 137.8 to 276.1 N - <i>from 31 to 62.07 lbf</i>

4 Handles

Some handles as examples are listed below: for technical specifications and full range of handles and other types of joint see the "Handles and handlevers" catalogue.

V series handle

TYPE: **V007-(Q)** CODE: 5IMP030071
DESCRIPTION: Without switches, with sloping 19° left joint and square seat bellow adapter

AMH series handle

TYPE: **AMH0400A9-6R2035(T)-7R2035(T)-8R2035(T)-9R2035(T)-(E2)** CODE: 2IM3000004
DESCRIPTION: 4 spring return push-buttons, protection diode, flying leads, straight joint and square seat bellow adapter

H series handle

TYPE: **HA029-ORD040-2RD040-4RD040** CODE: 2IM4100109
DESCRIPTION: 2 microswitch push-buttons on the operator side, "dead man" switch, flying leads, straight joint, for circular seat bellow

P series handle

TYPE: **PZTA4100D9-ORD035-3R1D035-4R1D035-5R1D035-6R1D035-WN130035** CODE: 2IM8600007
DESCRIZIONE: 1 proportional roller and 4 spring return push-buttons on operator side, "dead man" switch, flying leads, straight joint for circular seat bellow

MTH series handle

TYPE: **MTH-R00-ZTM31009-00-3N2035-5R2035-6N2035-7N2035-8N2035-DY2035-WG130035-(D2F12)** CODE: 2IM2000012
DESCRIPTION: 1 proportional roller and 3 spring return push-buttons on the operator side, 3 push buttons on the opposite side, straight joint, for circular seat bellow, Deutsch connector

XMH series handle

TYPE: **XMHZTA21008-2G2035-4G2035-7G2035-VG171035** CODE: 2IM1000004
DESCRIPTION: 1 proportional roller and 2 spring return push-buttons on the operator side, 1 push button with spring return on the opposite side, Deutsch connector, 19° sloping right joint, for square seat bellow

S series handle

TYPE: **SZTA8-0G4045-XG122045** CODE: 2IM5310003
DESCRIPTION: With proportional roller on the operator side and spring return push-button on the opposite side, 19° sloping right joint, for square seat bellow

F series handle

TYPE: **F02F-02R(1=8)** CODE: 320000251
DESCRIPTION: 2 microswitch push-buttons on the operator side and 2 on the opposite side, flying leads, 15° sloping joint, square seat bellow adapter, requires dedicated control

5 Handle position

TYPE	DESCRIPTION
(-)	STANDARD configuration, forward operation towards port 4: omitted in description
(90)	Mounted with 90° rotation step: forward operation towards port 1
(180)	Mounted with 180° rotation step: forward operation towards port 2
(270)	Mounted with 270° rotation step: forward operation towards port 3

NOTE (*) - Codes are referred to **BSP** thread.

Handle options

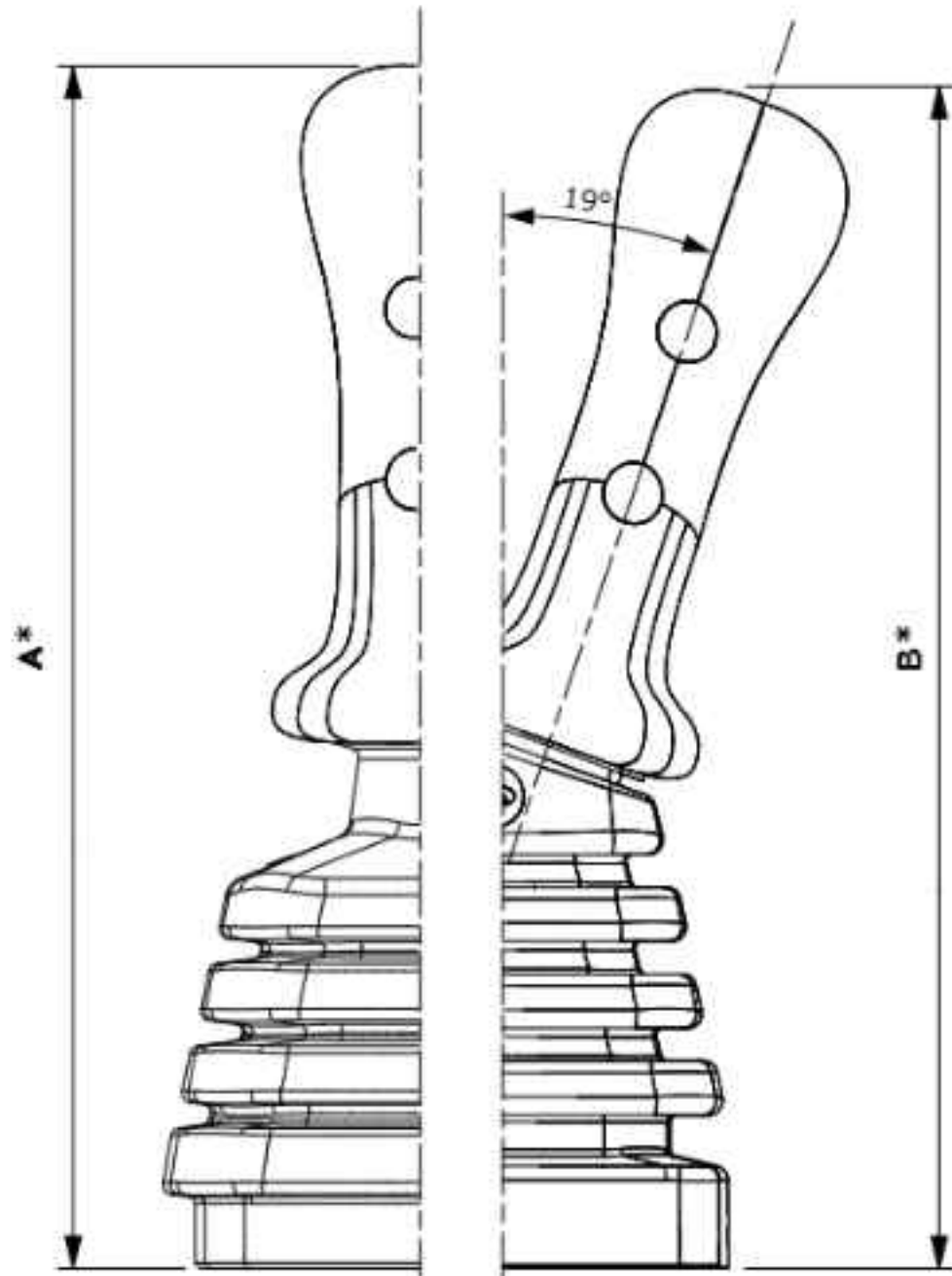

Handle positions

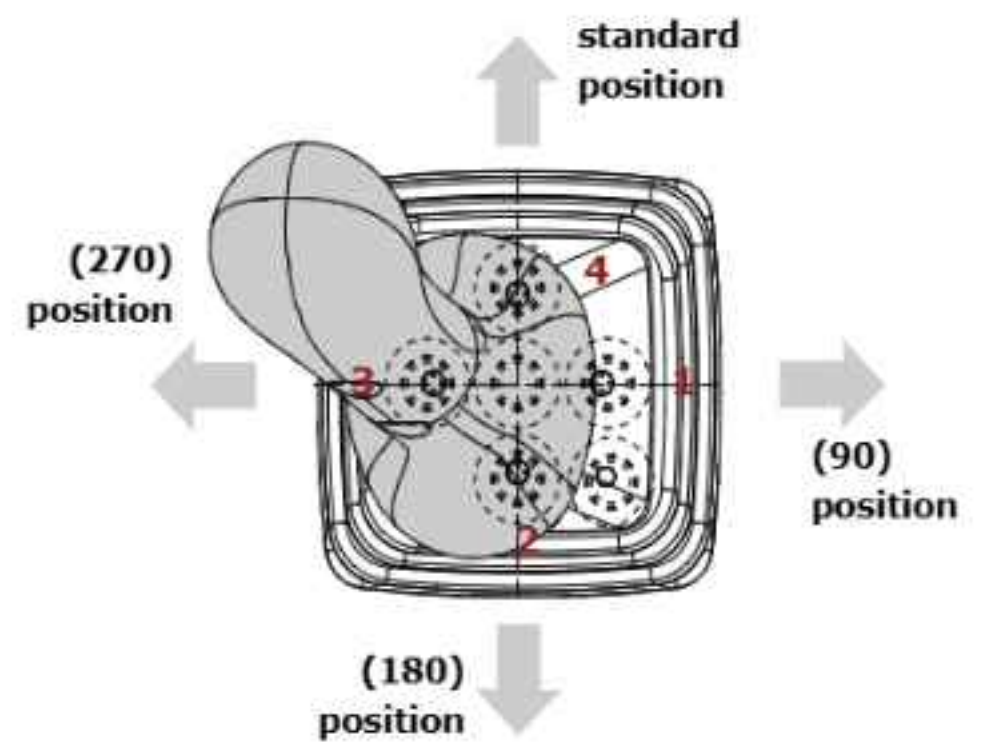

Type	A*		B*	
	mm	in	mm	in
V series	237	9.33	235	9.25
AMH series	193	7.60	193	7.60
H series	235	9.25	233	9.17
P series	254	10	252	9.92
MTH series	261	10.29	249	9.80
S series	250	9.84	247	9.72
XMH series	259	10.20	255	10.04
F series	241	9.49	237	9.33

(*) The overall dimensions are indicative

Control curves with and without step

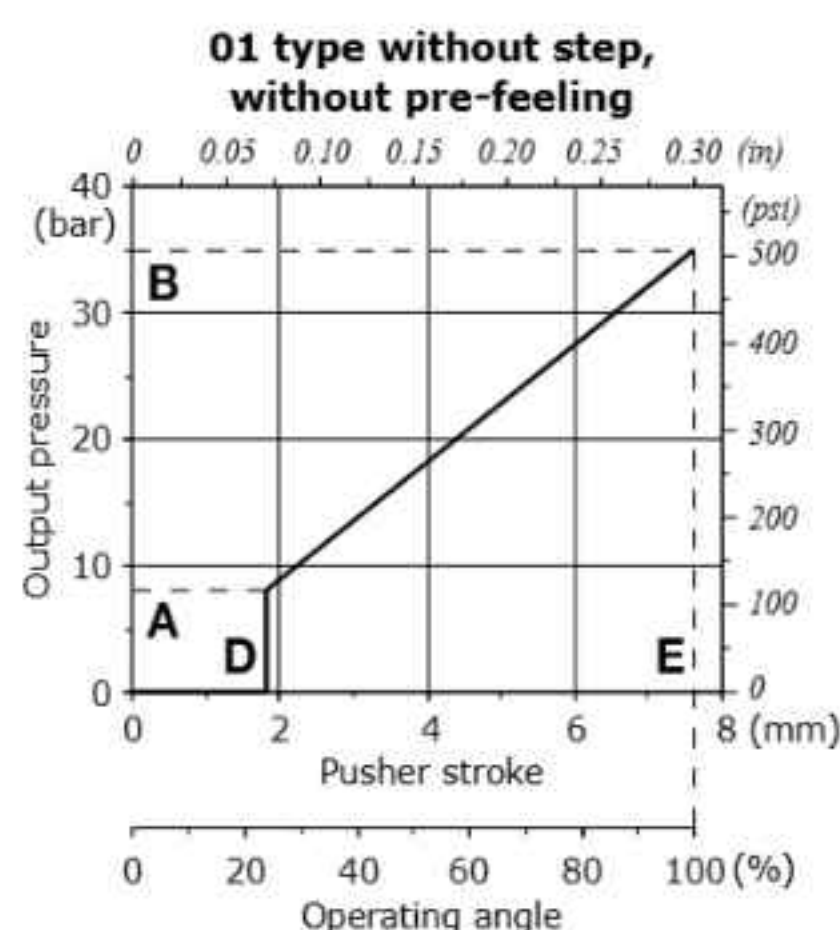
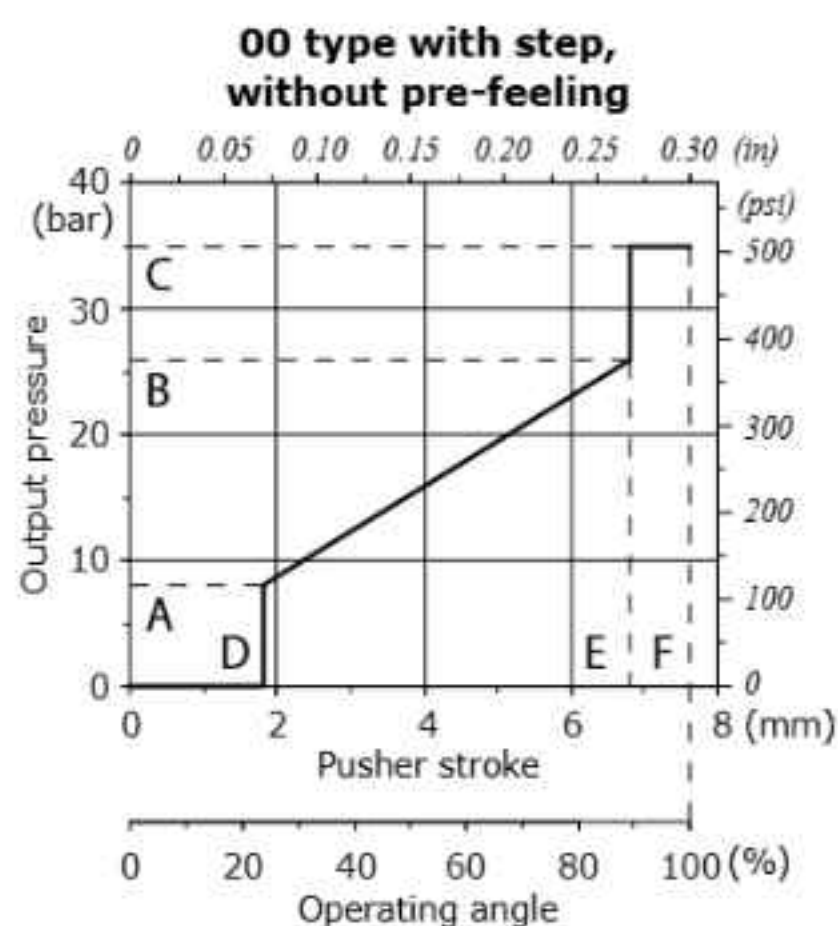

With step

Curve description		Pressure						Stroke						CODE ⁽¹⁾
Type	Nr	A		B		C		D		E		F		
		bar (\pm toll)	psi (\pm toll)	bar (\pm toll)	psi (\pm toll)	bar	psi	mm	in	mm	in	mm	in	
00	020	4.3 (\pm 0.5)	62.4 (\pm 7.25)	15.2 (\pm 1.5)	220.4 (\pm 21.75)	35	507.5	0.85	0.03	7.25	0.28	7.6	0.30	5CR800020CA
00	033	5.8 (\pm 0.5)	84.1 (\pm 7.25)	19 (\pm 1.5)	275.5 (\pm 21.75)	35	507.5	0.85	0.03	7.25	0.28	7.6	0.30	5CR800033CM
00	053	8 (\pm 1)	116 (\pm 14.5)	22.3 (\pm 1.5)	323.35 (\pm 21.75)	35	507.5	0.85	0.03	7.25	0.28	7.6	0.30	5CR800053CM
00	085	6 (\pm 1)	87 (\pm 14.5)	25 (\pm 1.5)	362.5 (\pm 21.75)	35	507.5	0.85	0.03	7.2	0.28	7.6	0.30	5CR800085CM
00	088	8 (\pm 1)	116 (\pm 14.5)	27 (\pm 1.5)	391.5 (\pm 21.75)	35	507.5	0.85	0.03	7.25	0.28	7.6	0.30	5CR800088CA
00	089	7.5 (\pm 0.75)	108.75 (\pm 10.87)	28 (\pm 2)	84.1 (\pm 29)	35	507.5	0.85	0.03	7.25	0.28	7.6	0.30	5CR800089CM
00	036	12 (\pm 0.5)	174 (\pm 7.25)	25 (\pm 1)	362.5 (\pm 21.75)	35	507.5	0.85	0.03	7.25	0.28	7.6	0.30	5CR800036CA

⁽¹⁾ Codes are referred to the curve with the specific return spring
For different curves please contact our Sales Department

Without step

Curve description		Pressure				Stroke				Code ⁽¹⁾
Type	Nr	A		B		D		E		
		bar (\pm toll)	psi (\pm toll)	bar (\pm toll)	psi (\pm toll)	mm	in	mm	in	
01	111	5.5 (\pm 1)	79.75 (\pm 14.5)	25.5 (\pm 1.5)	369.75 (\pm 21.75)	0.85	0.03	7.6	0.30	5CR801111CA
01	197	6 (\pm 1)	87 (\pm 14.5)	24.5 (\pm 2)	355.25 (\pm 29)	0.85	0.03	7.6	0.30	5CR801197CM
01	198	6.2 (\pm 0.5)	89.9 (\pm 7.25)	23.2 (\pm 1)	336.4 (\pm 14.5)	0.85	0.03	7.6	0.30	5CR801198CM

⁽¹⁾ Codes are referred to the curve with the specific return spring
For different curves please contact our Sales Department



SVM hydraulic joystick with differential area

SVM980

- Low operating effort
- Possibility to manage and regulate high flow rates
- Cast iron body for high strength and reliability

Working conditions

This catalogue shows technical specifications and diagrams measured through mineral oil of 46mm²/s - 46 cSt viscosity at 40°C - 104°F temperature.

Nominal flow rating		from 5 to 20 l/min - from 1.32 to 5.28 USgpm
Max. feeding pressure	on P inlet port	from 30 to 100 bar - from 435 to 1450 psi
Max. backpressure	on T outlet port	4 bar - 58 psi
Max. hysteresis		0,5 bar - 7.25 psi
Internal leakage (all ports)	at 30 bar - 435 psi, P⇒T	max. 50 cm ³ /min - 3.05 in ³ /min
Fluid		Mineral oil
Fluid temperature	with NBR (BUNA-N) seals	from -10°C to 80°C - from 14 °F to 176 °F
	operating range	from 15 to 75 mm ² /s - from 15 to 75 cSt
Viscosity	min.	3 mm ² /s - 3 cSt
	max.	400 mm ² /s - 400 cSt
Max. contamination level		-/18/15 - ISO 4406
Ambient temperature	without electric devices	from -40°C to 60°C - from 40 °F to 140 °F
	with electric devices	from -20°C to 50°C - from -4 °F to 122 °F

NOTE - for different conditions please contact our Sales Department.

REFERENCE STANDARD

		BSP	BSI	UN-UNF
THREAD ACCORDING TO		ISO 228/1	ISO 228/1	ISO 263
		BS 2779	BS 2779	ANSI B1.1 unified
CAVITY DIMENSION ACCORDING TO	ISO	1179	8434-1	11926
	SAE			J11926
	DIN	3852-2 X or Y shape		

PORT THREADING

PORTS	Threads			Fitting tightening torque	
	ISO 1179	ISO 8434-1	ISO 11926-2	Nm	lbft
P inlet	G 1/4	G 1/4	9/16-18 (SAE 6)	30	22.13
Ports	G 1/4	G 1/4	9/16-18 (SAE 6)	30	22.13
T outlet	G 1/4	G 1/4	9/16-18 (SAE 6)	30	22.13

NOTE - These torques are recommended. Assembly tightening torque depends on many factors, including lubrication, coating and surface finishing. The manufacturer has to be consulted.

Features

SVM980 is a new hydraulic joystick with differential area.

This product expands the range of the family by adding a unique product with at least two key features:

- **Original and patented project**
New construction architecture that offers an innovative and patented product.
- **High reliability**
The cast iron body and treated rod ensure long life, higher resistance to oil contamination and maintain characteristics (such as leakage) over the life of the joystick.
- **High operating comfort**
Lowest operator actuation forces of the entire hydraulic joystick family.
- **High performance**
The possibility to manage and regulate higher flow rates, thanks to the large diameters of the rods, a useful and necessary condition especially on large machines.
- **Versatility of configurations**
Wide possibilities to complete and customize the hydraulic joystick, thanks to the compatibility with all the handles of the Walvoil range and modularity of the fixing flanges.

Comparison between SVM980 and SVM std.

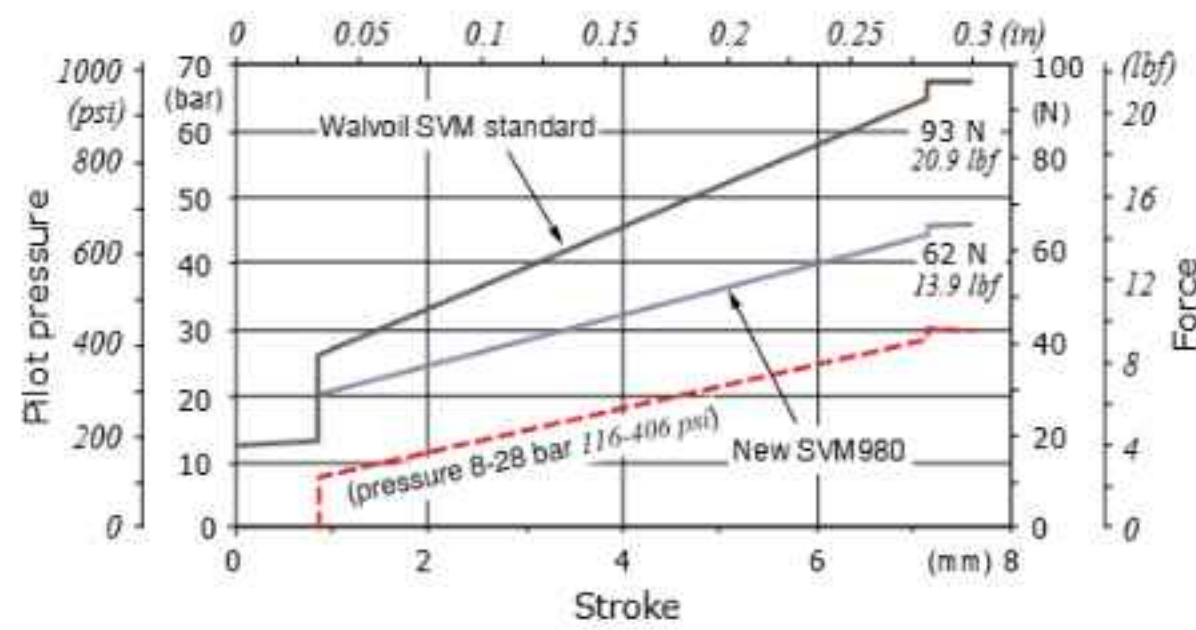

Dimensions and hydraulic circuit

a : Minimum fixing diameter
b : Maximum fixing diameter

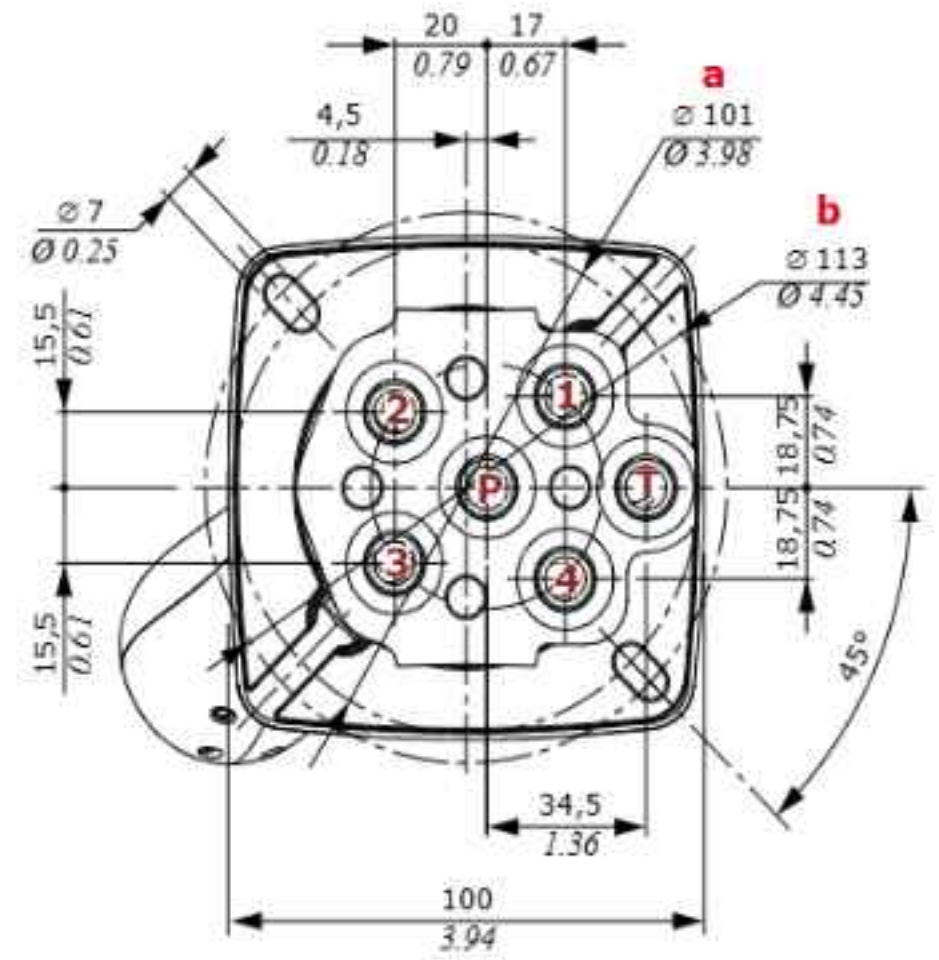

NOTE: normally the pilot control valve is supplied with the handle oriented towards ports nr. 3/4 (see page 28)

Hydraulic circuit

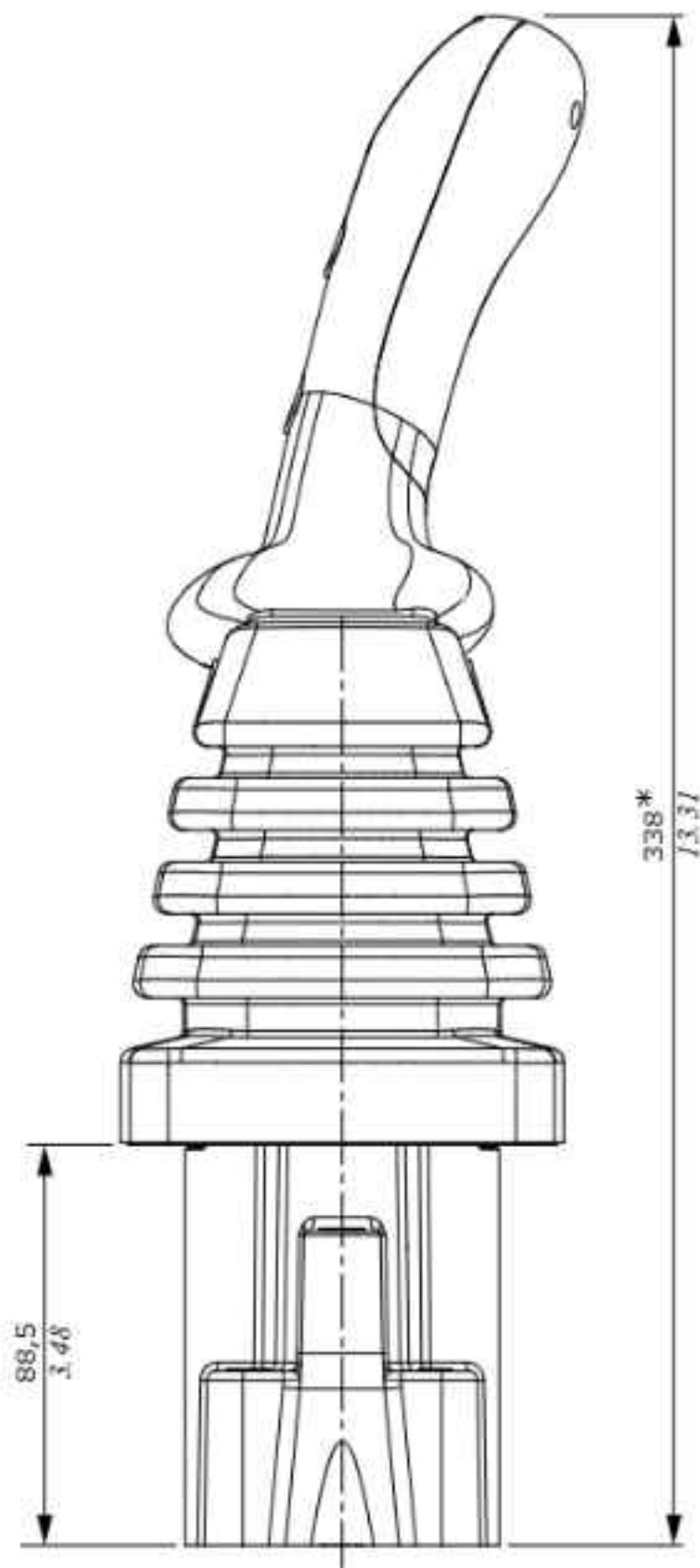
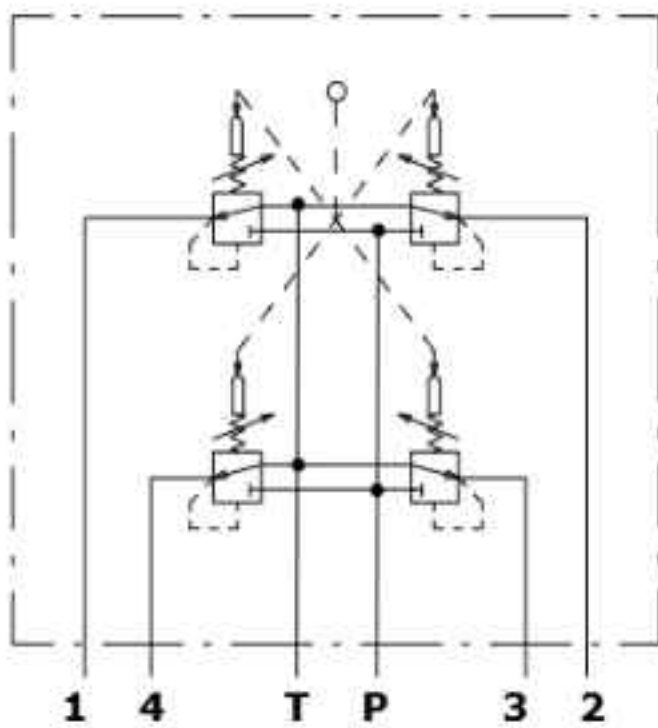

(*) S type handle

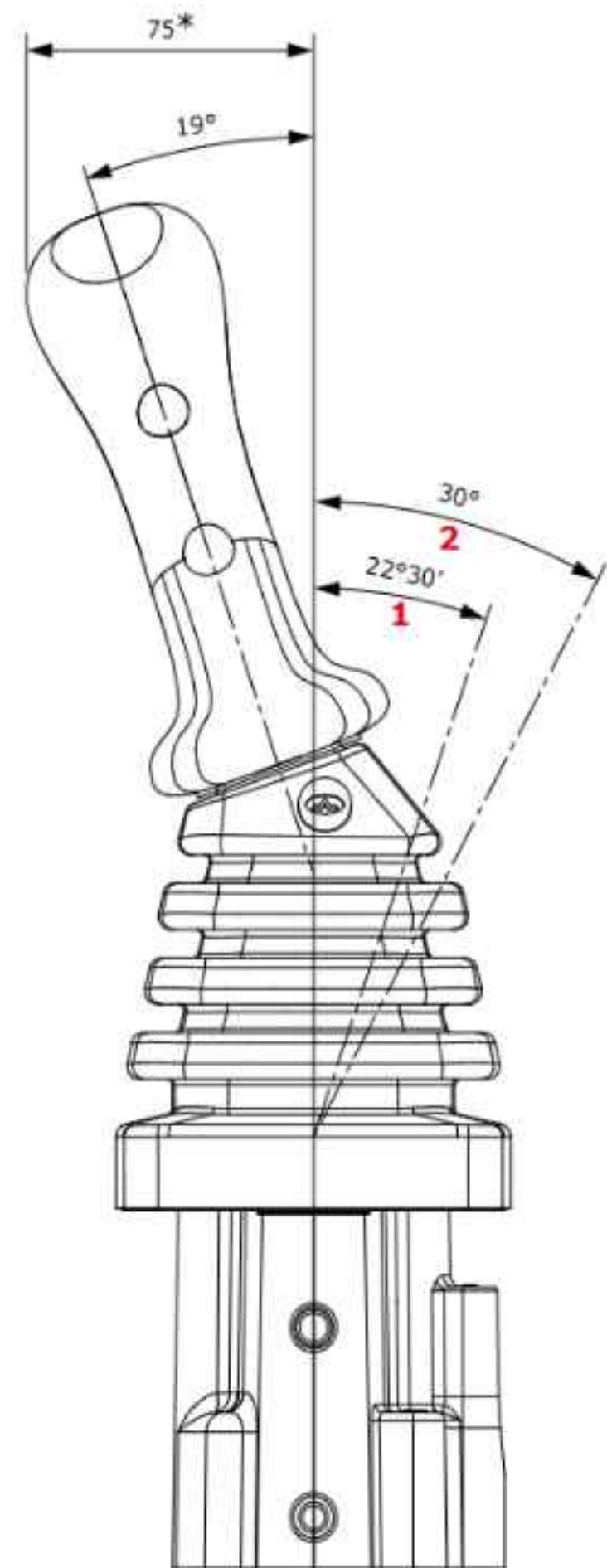

1 : Single work port
2 : Two simultaneous work ports

Ordering codes

SVM980 / 3 1-B / 01SC S108 (90) - 045(TM1M) - 0 0 89C A X 4 - <CRVN>

Body is painted as standard, with one coat of primer black antirust paint

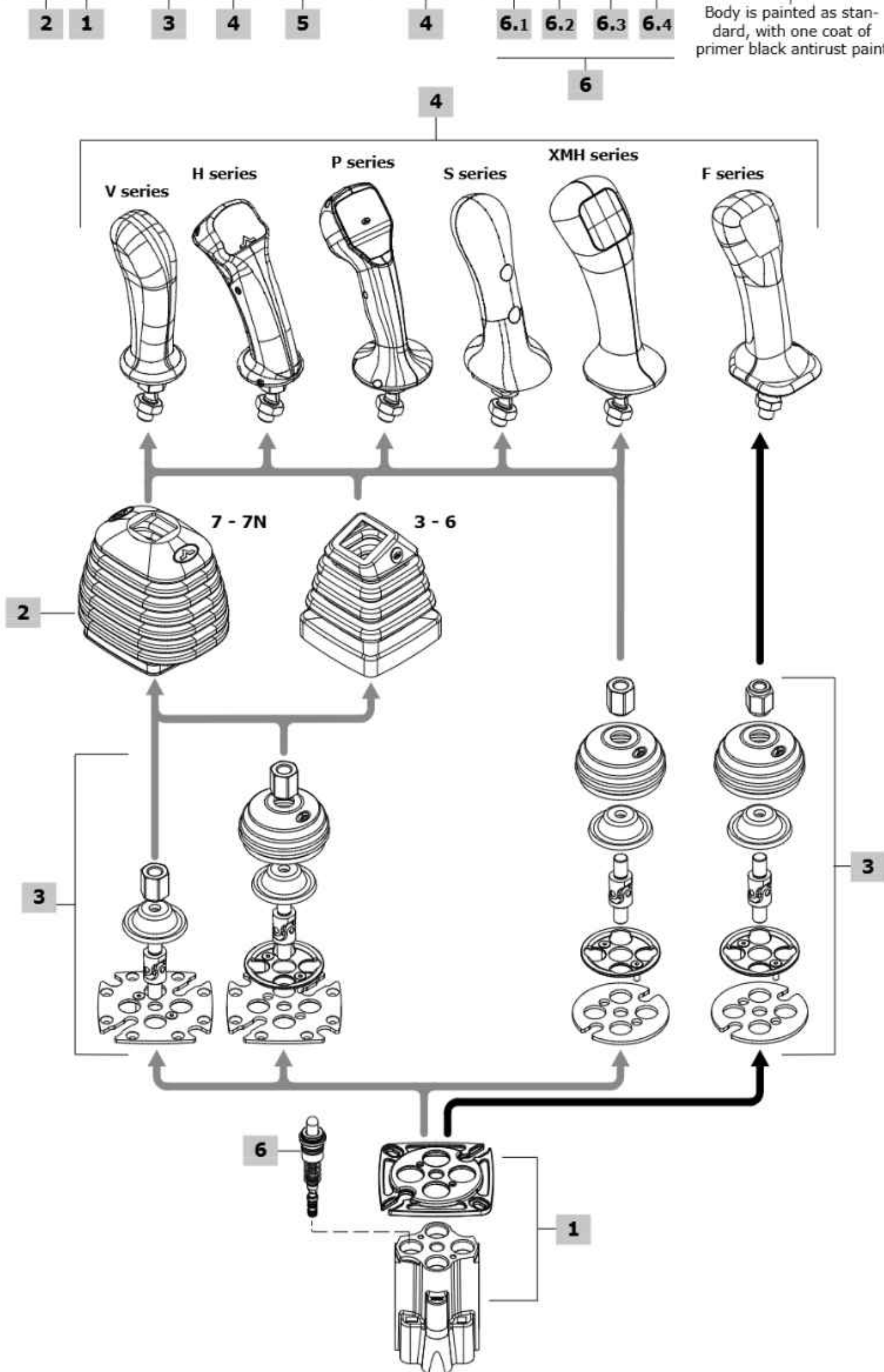

1 Body kit *

TYPE	CODE	DESCRIPTION
SVM980/1-B	5CO3980300-C	Body kit with cast iron body, BSP thread, double rubber bellow arrangement
SVM980/1-J	5CO3980800-C	As previous one, BSI thread

2 Rubber bellow

TYPE	CODE	DESCRIPTION
3	3SOF111113	Sloping type, square base with logo; only for 19° sloping handles
6	3SOF111114	As previous one without logo
7	3SOF111135	Universal type, rectangular base, with logo and it can be used straight and 30° sloping in all directions
7N	3SOF111137	As previous one without logo

3 Control option

TYPE	CODE	DESCRIPTION
01	5CIN9801-C	With spring return in neutral position, with additional protective rubber bellow
01SC	5CIN9800-C	With spring return in neutral position, without main rubber bellow, with only circular protective rubber bellow
01SCF	5CIN405F01	As previous one, for F type handle
01DS	5CIN9802-C	With spring return in neutral position, with circular protective rubber bellow and arrangement for main rubber bellow

4 Handles

Some handles as examples are listed below; for technical specifications and full range of handles and other types of joint see the "Handles and handlevers" catalogue.

V series handle

TYPE: **V007-(Q)** CODE: 5IMP030071
DESCRIPTION: Without switches, with sloping 19° left joint, square seat bellow adapter

H series handle

TYPE: **HTA048-(Q)-0R040-2Y1040-3R1040-4N2040-5V2040**
CODE: 2IM4700007
DESCRIPTION: 4 spring return push-buttons on the operator side, "dead man" switch, flying leads, sloping 19° right joint, square seat bellow adapter

P series handle

TYPE: **PZMA1200B7-0R035-3Y2D035-WN130035-ZN130035-(SCHEDA 2PWM)-(TD2M)** CODE: 2IM8700003
DESCRIZIONE: 2 proportional roller and 1 spring return push-button on operator side, "dead man" switch, flying leads with Deutsch pins, sloping 19° left joint, square seat bellow adapter

XMH series handle

TYPE: **XMHZTA21008-2G2035-4G2035-7G2035-VG171035**
CODE: 2IM1000004
DESCRIPTION: 1 prop. roller and 2 spring return push-buttons on the operator side, 1 push button with spring return on the opposite side, Deutsch connector, 19° sloping right joint, for square seat bellow

S series handle

TYPE: **SZTA8-0G4045-XG122045** CODE: 2IM5310003
DESCRIPTION: With proportional roller on the operator side and spring return push-button on the opposite side, 19° sloping right joint, for square seat bellow

F series handle

TYPE: **F02F-02R(1=8)** CODE: 320000251
DESCRIPTION: 2 microswitch push-buttons on the operator side and 2 on the opposite side, flying leads, 15° sloping joint, square seat bellow adapter, requires dedicated control

5 Handle position

TYPE	DESCRIPTION
(-)	STANDARD configuration, forward operation on work port 3/4: omitted in description
(90)	Mounted with 90° rotation step: forward operation towards ports 4-1
(180)	Mounted with 180° rotation step: forward operation towards ports 1-2
(270)	Mounted with 270° rotation step: forward operation towards ports 2-3

6 Pressure control curves

For list available see from page 47

6.1 Curve type

TYPE	DESCRIPTION
0	Standard

6.2 Typology of curves

TYPE	DESCRIPTION
0	With step
1	Without step

6.3 Curve identification

Progressive number

6.4 Return springs

TYPE	DESCRIPTION
A	Operation range from 23 to 35.2 N - <i>from 5.17 to 7.91 lbf</i>

NOTE (*) - Codes are referred to **BSP** thread.

Configuration option

Handle options

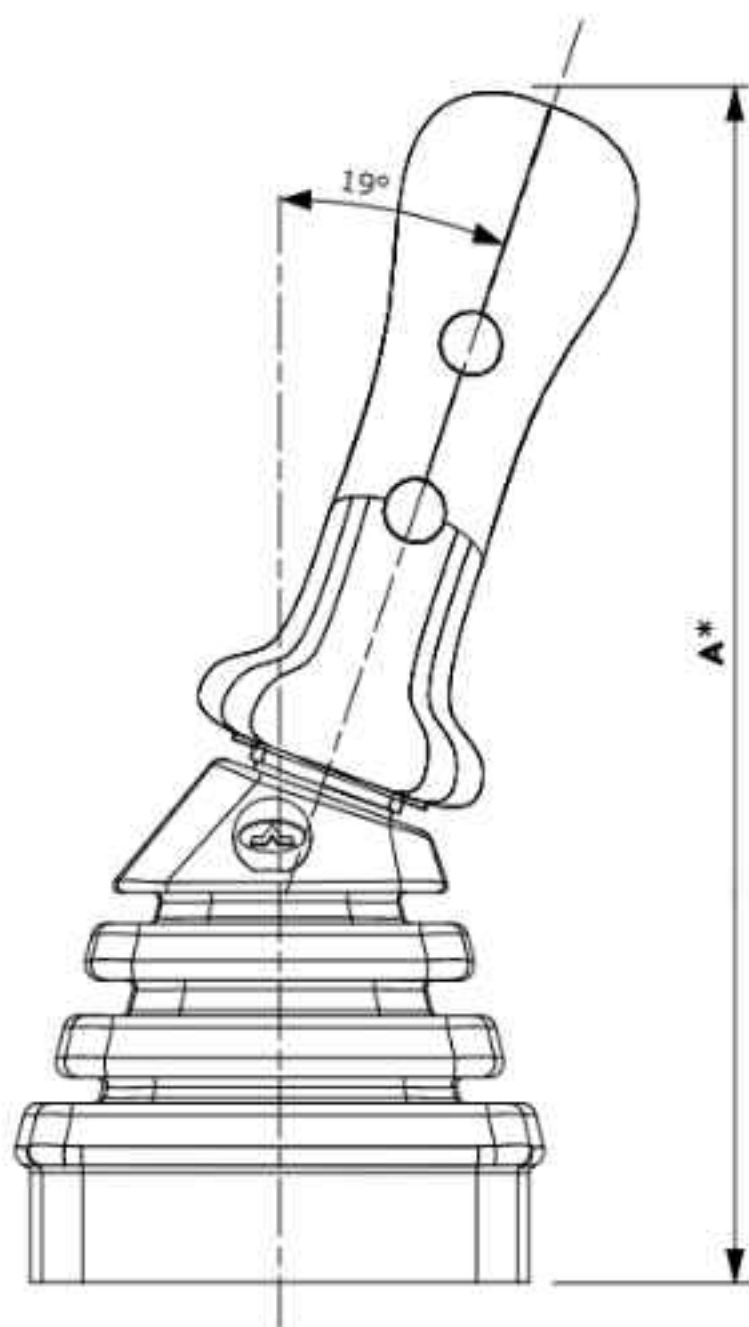

Type	A*	
	mm	in
V series	238	9.37
H series	236	9.29
P series	255	10.04
S series	250	9.84
XMH series	258	10.16
F series	240	9.45

(*) The overall dimensions are indicative

Handle positions

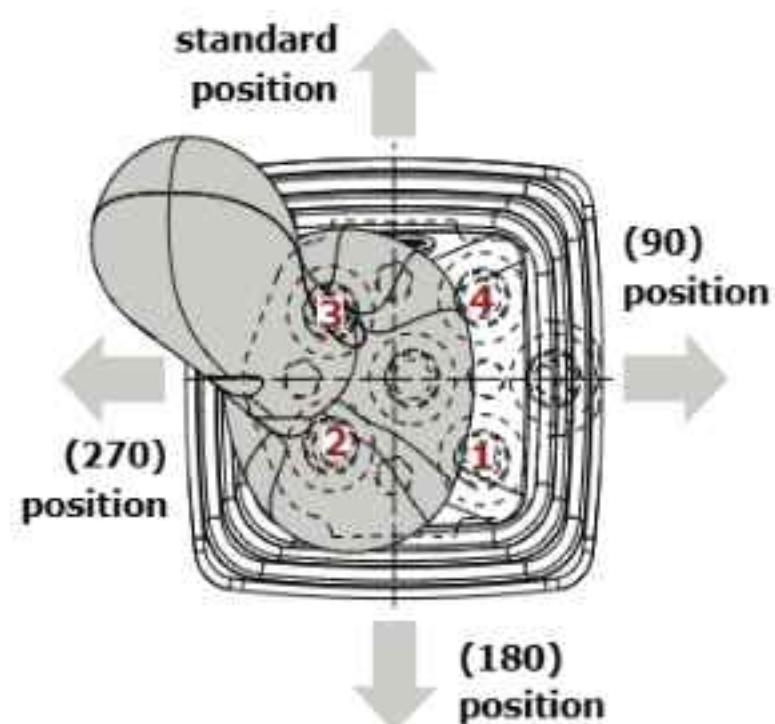

Control curves with and without step

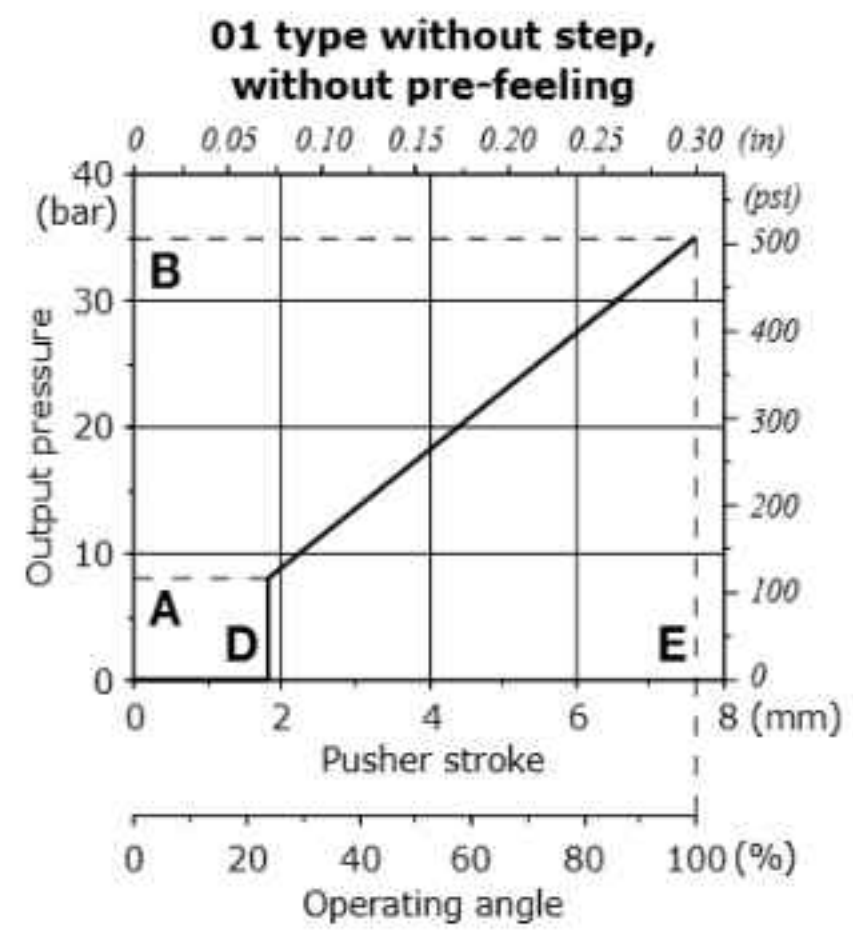
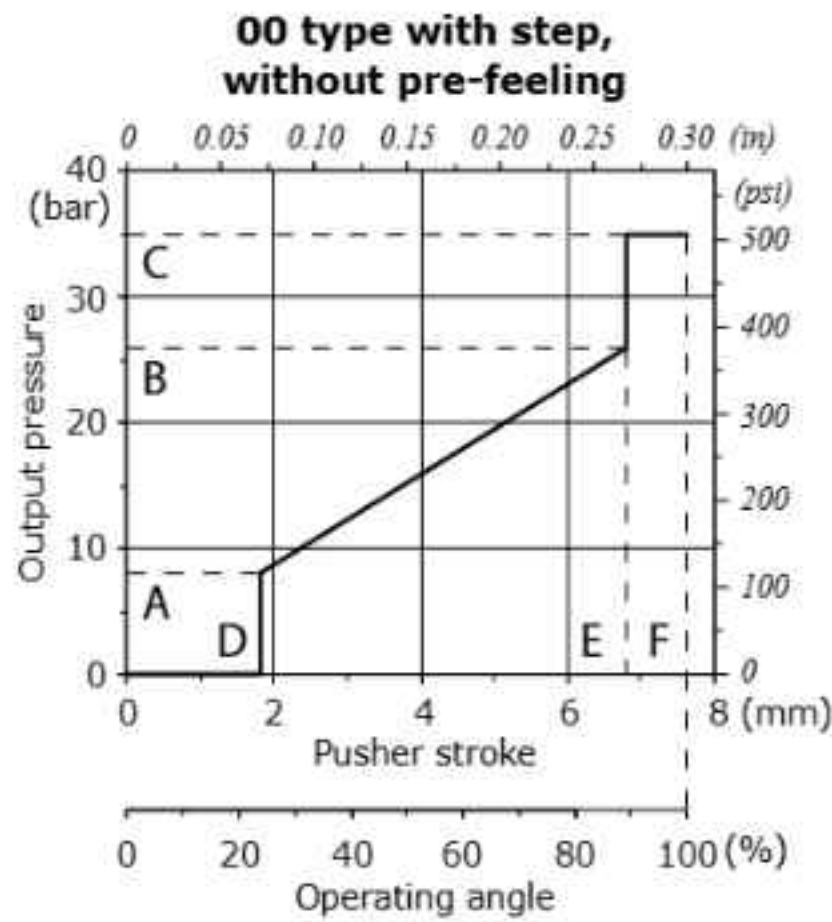

With step

Curve description		Pressure						Stroke						CODE ⁽¹⁾
Type	Nr	A		B		C		D		E		F		
		bar (\pm toll)	psi (\pm toll)	bar (\pm toll)	psi (\pm toll)	bar	psi	mm	in	mm	in	mm	in	
0	028C	5 (\pm 1)	72.5 (\pm 14.5)	21 (\pm 1)	304.5 (\pm 14.5)	35	507.5	1.1	0.04	6.4	0.25	7	0.28	
0	093C	5 (\pm 0.5)	72.5 (\pm 7.25)	26 (\pm 1)	377 (\pm 14.5)	35	507.5	1.1	0.04	8	0.31	8.6	0.34	
0	135C	5.4 (\pm 1)	78.3 (\pm 14.5)	20 (\pm 1.5)	290 (\pm 21.75)	35	507.5	1.1	0.04	6.4	0.25	7	0.28	
0	133C	5.8 (\pm 0.5)	84.1 (\pm 7.25)	22 (\pm 1)	319 (\pm 14.5)	35	507.5	1.1	0.04	6.4	0.25	7	0.28	
0	001C	5.8 (\pm 0.5)	84.1 (\pm 7.25)	22 (\pm 1)	319 (\pm 14.5)	35	507.5	1.1	0.04	8	0.31	8.6	0.34	
0	111C	6 (\pm 0.5)	87 (\pm 7.25)	25 (\pm 1)	362.5 (\pm 14.5)	35	507.5	1.1	0.04	8	0.31	8.6	0.34	
0	131C	7 (\pm 0.5)	101.5 (\pm 7.25)	25.7 (\pm 1)	369.75 (\pm 14.5)	35	507.5	1.1	0.04	8	0.31	8.6	0.34	
0	132C	8 (\pm 1)	116 (\pm 14.5)	28 (\pm 1.5)	406 (\pm 21.75)	35	507.5	1.1	0.04	6.4	0.25	7	0.28	
0	089C	8 (+0.4/-0.7)	116 (+5.8/-10.15)	28 (+1.4/-0.8)	406 (+20.3/-11.6)	35	507.5	1.1	0.04	8	0.31	8.6	0.34	

⁽¹⁾ Codes are referred to the curve with the specific return spring
For different curves please contact our Sales Department

Without step

Curve description		Pressure				Stroke				CODE ⁽¹⁾
Type	Nr	A		B		D		E		
		bar (\pm toll)	psi (\pm toll)	bar (\pm toll)	psi (\pm toll)	mm	in	mm	in	
1	135C	5,8 (\pm 0,5)	79.75 (\pm 14.5)	23 (\pm 1,5)	369.75 (\pm 21.75)	1,1	0.03	8,6	0.30	
1	172C	7 (\pm 0,5)	87 (\pm 14.5)	23,5 (\pm 1,5)	355.25 (\pm 29)	1,1	0.03	7	0.30	
1	199C	7,4 (\pm 0,5)	89.9 (\pm 7.25)	23,5 (\pm 1)	336.4 (\pm 14.5)	1,1	0.03	7	0.30	

⁽¹⁾Codes are referred to the curve with the specific return spring
For different curves please contact our Sales Department





SVM hydraulic joysticks with electromagnetic detent

SVM150 / SVM450 / SVM600

- Single, double and combined functions
- Wide range of handles available

Working conditions

This catalogue shows technical specifications and diagrams measured through mineral oil of 46mm²/s - 46 cSt viscosity at 40°C - 104°F temperature.

Nominal flow rating		from 5 to 20 l/min - from 1.32 to 5.28 USgpm
Max. feeding pressure	on P inlet port	from 30 to 100 bar - from 435 to 1450 psi
Max. backpressure	on T outlet port	3 bar - 43.5 psi
Max. hysteresis		0.5 bar - 7.25 psi
Internal leakage (all ports)	at 30 bar - 435 psi, P⇒T	from 2.5 to 4.5 cm ³ /min - from 0.15 to 0.27 in ³ /min
Fluid		Mineral oil
Fluid temperature	with NBR (BUNA-N) seals	from -10°C to 80°C - from 14 °F to 176 °F
	operating range	from 15 to 75 mm ² /s - from 15 to 75 cSt
Viscosity	min.	12 mm ² /s - 12 cSt
	max.	400 mm ² /s - 400 cSt
Max. contamination level		-/15/12 - ISO 4406 - NAS1638 class 6
Ambient temperature	without electric devices	from -40°C to 60°C - from 40 °F to 140 °F
	with electric devices	from -20°C to 50°C - from -4 °F to 122 °F
Tie rod tightening torque (wrench 13)	only for SVM150	24 Nm - 17.7 lbft

NOTE - for different conditions please contact our Sales Department.

REFERENCE STANDARD

	BSP	UN-UNF
THREAD ACCORDING TO	ISO 228/1	ISO 263
	BS 2779	ANSI B1.1 unified
CAVITY DIMENSION ACCORDING TO	ISO 1179	11926
	SAE	J11926
	DIN 3852-2 X or Y shape	

PORT THREADING

PORTS	UNI EN ISO 1179	Threads		Fitting tightening torque	
		UNI EN ISO 11926-2		Nm	lbft
		SVM150	SVM450-SVM600		
P inlet	G 1/4	7/16-20 (SAE 4)	9/16-18 (SAE 6)	30	22.13
Ports	G 1/4	7/16-20 (SAE 4)	9/16-18 (SAE 6)	30	22.13
T outlet	G 1/4	7/16-20 (SAE 4)	9/16-18 (SAE 6)	30	22.13

NOTE - These torques are recommended. Assembly tightening torque depends on many factors, including lubrication, coating and surface finishing. The manufacturer has to be consulted.

Dimensions and hydraulic circuit

Single axis type

Without detent or with detent on single working port or both working ports

Features

ELECTROMAGNET

Nominal voltage tolerance.....	: ±10%
Power rating	: 8.2 W
Nominal current.....	: 0.69 A - 12 VDC
	: 0.345 A - 24VDC
Coil insulation	: Class H
Weather protection.....	: IP65
Insertion.....	: 100%

SVM150/n type

Multiple function configuration; up to 5 sections

Hydraulic circuit

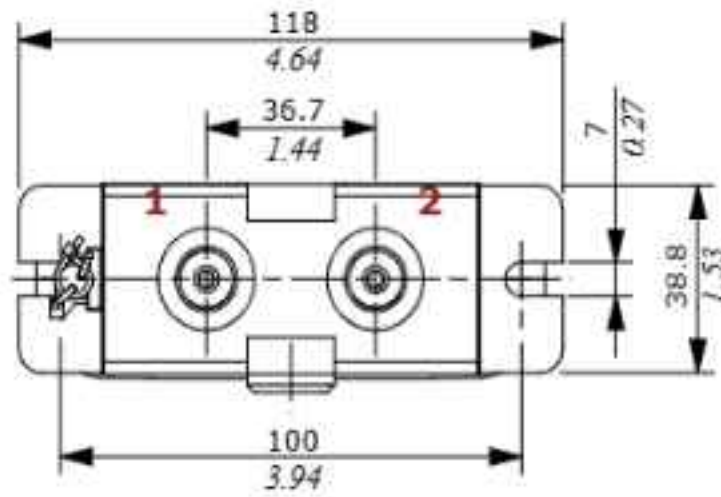
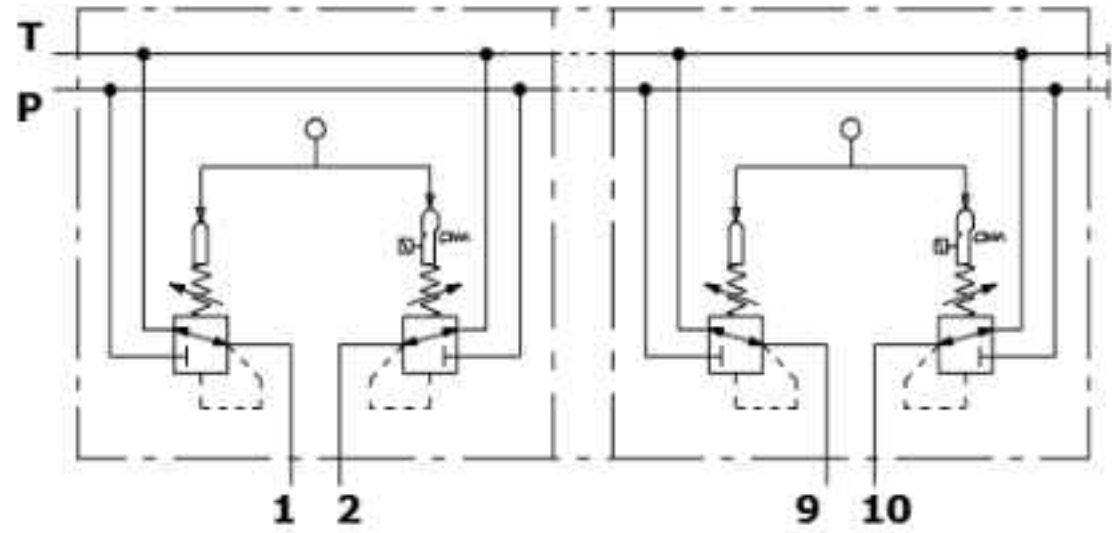

TYPE	E		F	
	mm	in	mm	in
SVM150/2	78	3.07	84	3.31
SVM150/3	117	4.61	123	4.84
SVM150/4	156	6.14	162	6.38
SVM150/5	195	7.68	201	7.91

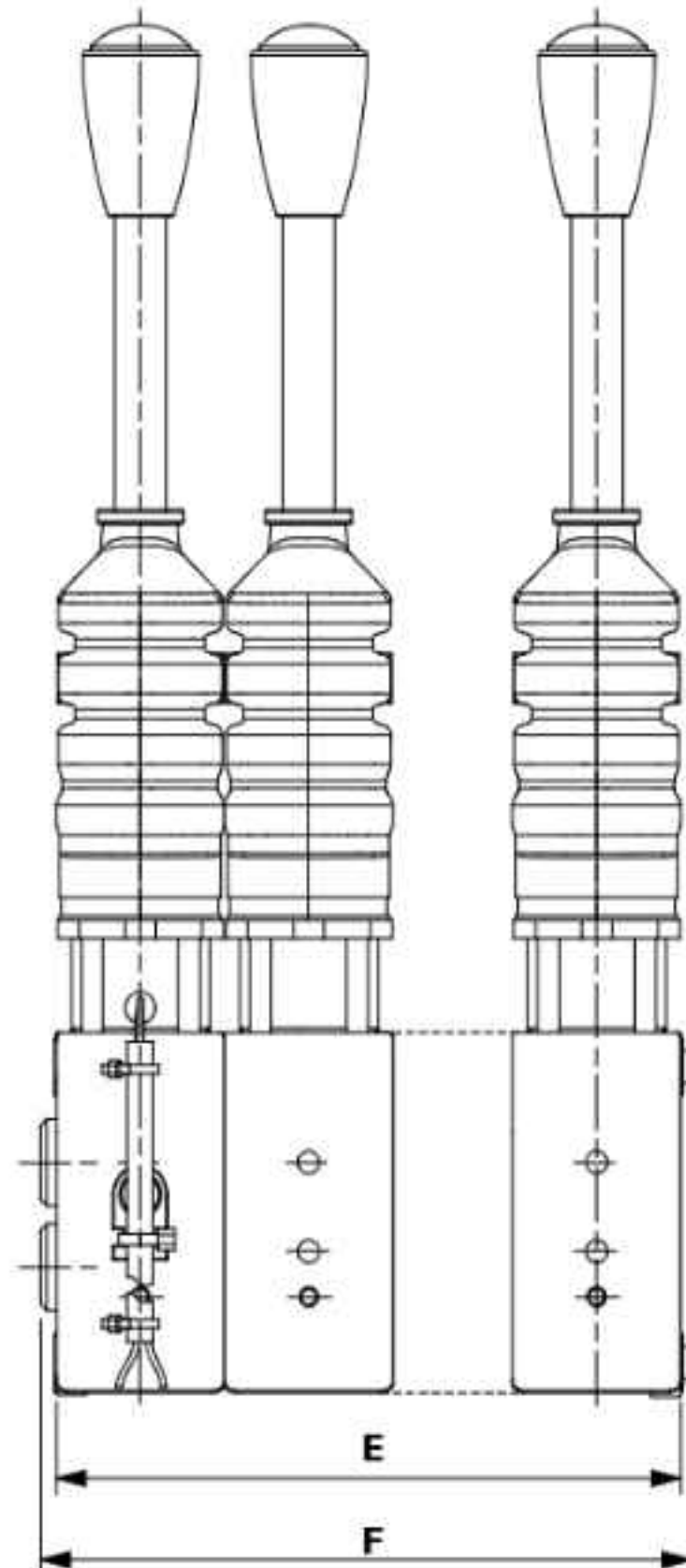
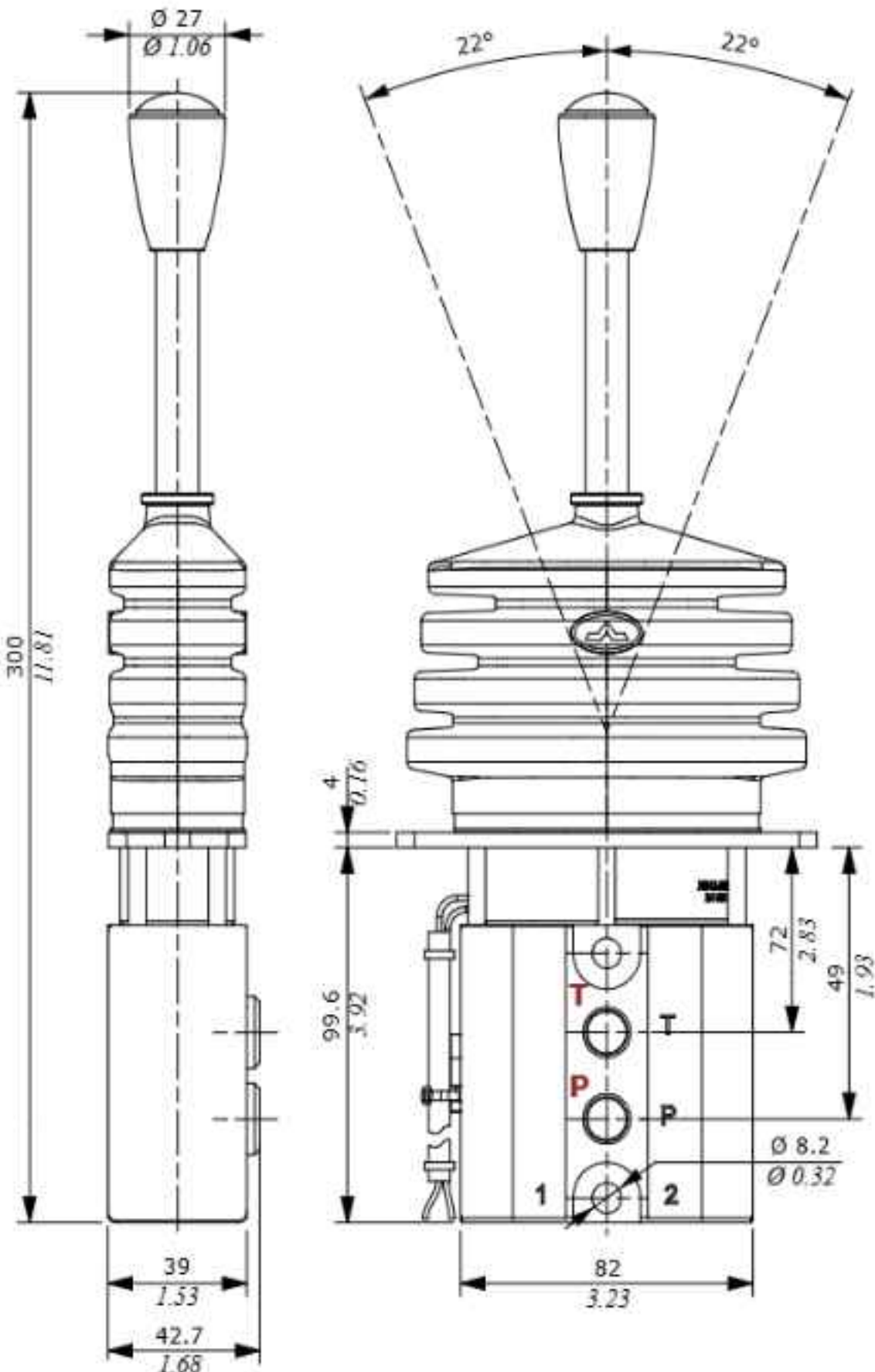

Ordering codes

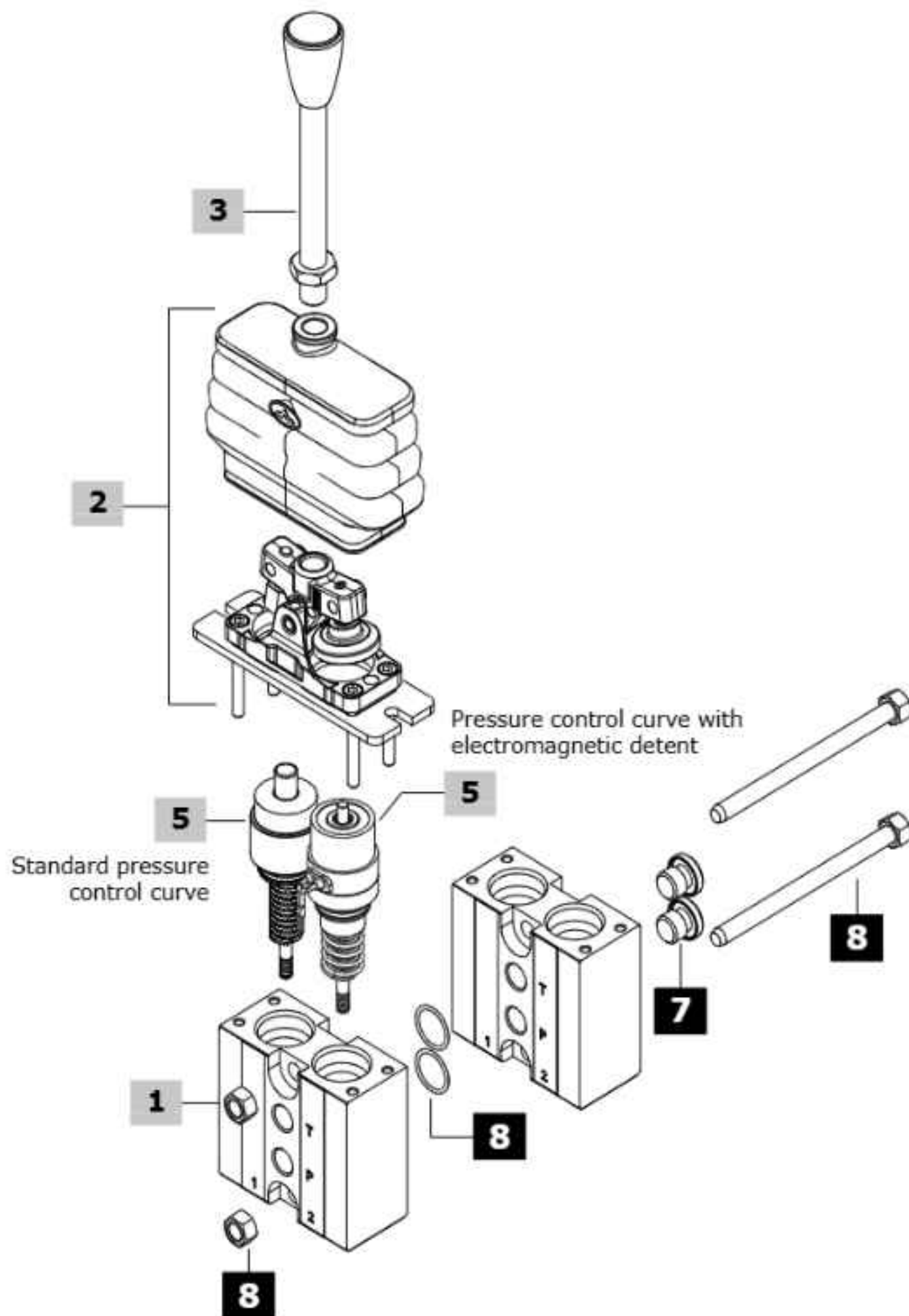
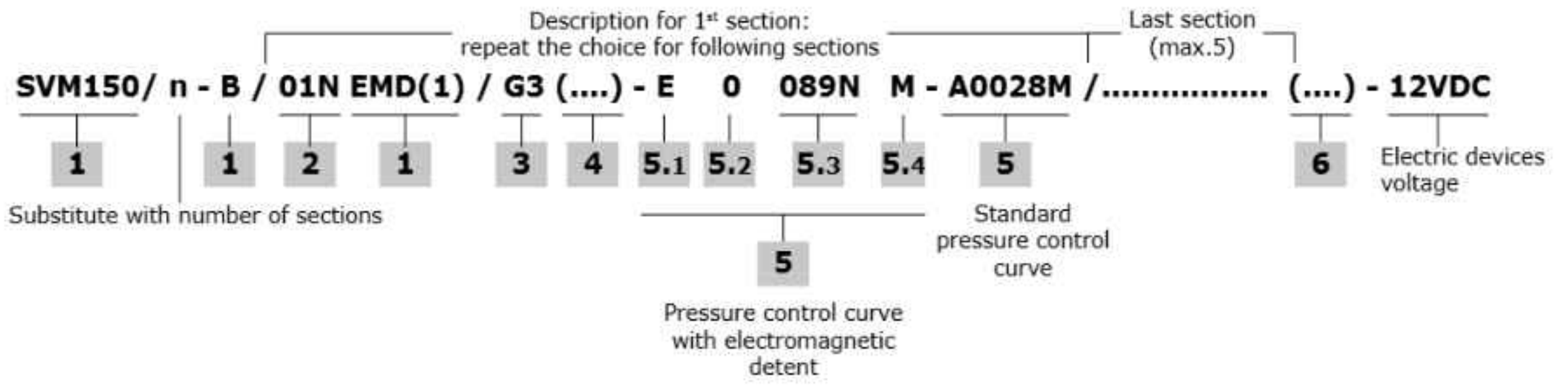

Ordering codes

1 Body kit *

TYPE: SVM150-B/EMD(0)	CODE: 5CO3132300
DESCRIPTION: Body without detent	
TYPE: SVM150-B/EMD(1)	CODE: 5CO3132301
DESCRIZIONE: Body with detent arrangement on port 1	
TYPE: SVM150-B/EMD(2)	CODE: 5CO3132302
DESCRIPTION: Body with detent arrangement on port 2	
TYPE: SVM150-B/EMD(1-2)	CODE: 5CO3132303
DESCRIPTION: Body with detent arrangement on ports 1 and 2	

2 Detent configuration

Complete with rubber bellow and fixing wrapper

TYPE	CODE	DESCRIPTION
01N(0D)	5CIN1010DN	Spring return to neutral position, without detent arrangement
01N(1D)	5CIN10110ND	Spring return to neutral position, single detent arrangement; right or left position is defined by pressure control curve position
01N(2D)	5CIN10120ND	Spring return to neutral position, double detent arrangement

NOTES: For detent arrangement on different ports, please contact our Sales Department.

The text between () can be omitted from composition description.

3 Standard handlevers

TYPE	CODE	DESCRIPTION
G3	5AST271218G	Ogival with portlight, straight rod (STANDARD)
G3(15)	5AST371227G	Ogival with portlight, 15° sloping rod
G3(30)	5AST371228G	Ogival with portlight, 30° sloping rod
E	5AST371215E	Spherical with portlight, 15° sloping rod

4 Handle position**Only for sploping rod**

TYPE	DESCRIPTION
(0)	Handlever oriented towards plugged P and T ports
(90)	Handlever oriented towards port 1
(180)	Handlever oriented towards open P and T ports
(270)	Handlever oriented towards port 2

5 Pressure control curves

For list available see from page 63

5.1 Curve type

TYPE	DESCRIPTION
A	Without pre-feeling, without solenoid
B	With pre-feeling, without solenoid
C	With solenoid 24VDC and pre-feeling
D	With solenoid 24VDC, without pre-feeling
E	With solenoid 12VDC, with pre-feeling
F	With solenoid 12VDC, without pre-feeling
G	With solenoid 24VDC and pre-feeling after step

5.2 Typology of curves

TYPE	DESCRIPTION
0	With step
1	Without step

5.3 Curve identification

Progressive number,

5.4 Return springs

TYPE	DESCRIPTION
M	Operation range from 18 to 25.5 N - <i>from 4.04 to 5.73 lbf</i>
A	Operation range from 23 to 35.2 N - <i>from 5.17 to 7.91 lbf</i>

6 Connector

Configurations with detent or microswitch are provided with wires with tin-plate terminals. For connectors please contact our Sales Department.

7 Closing plugs *

CODE	DESCRIPTION
3XTAP719150	G1/4 plug for rear ports closing (n. 2 plugs)

8 Assembling kit

This kit contains tie rods, nuts and O-ring seals.

CODE	DESCRIPTION
5TIR108081	Assembling kit for SVM150/2
5TIR108127	Assembling kit for SVM150/3
5TIR108159	Assembling kit for SVM150/4
5TIR108199	Assembling kit for SVM150/5

NOTE (*) - Codes are referred to BSP thread

Detent configuration

01/0D type

Spring return, without detent

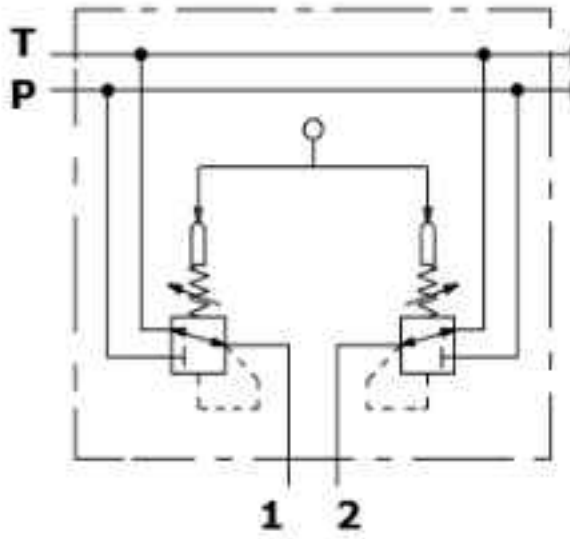

01/1D type

Single detent on port 2 (detent on port 1 on request), spring return



01/2D type

Double detent on ports 1 and 2, spring return

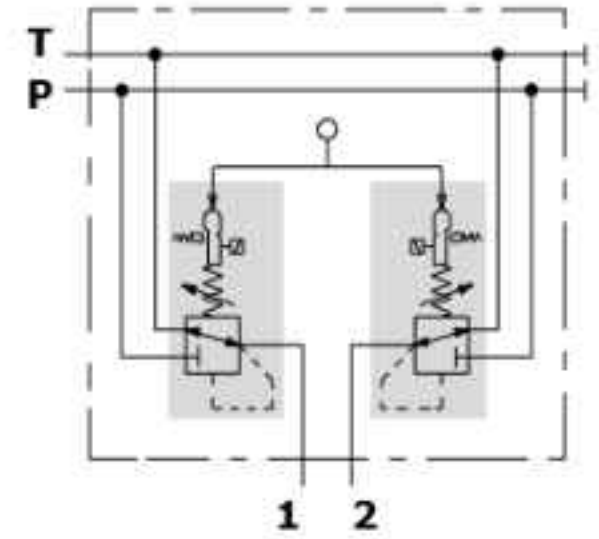

Standard handlevers

G type: Ogival handles with customizable portlight. It's possible to insert labels with specific machine functions (for example: lifting function): please contact our Sales Department.

E type: Spherical handle customizable as G type.

G type
straight rod

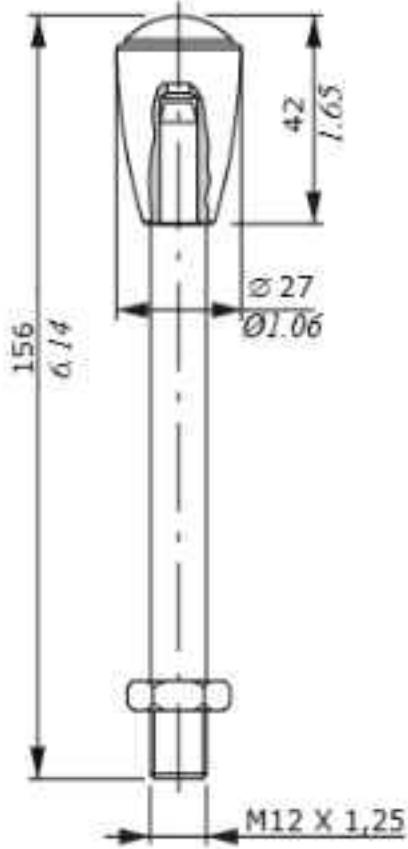

G(15) type
15° sloping rod

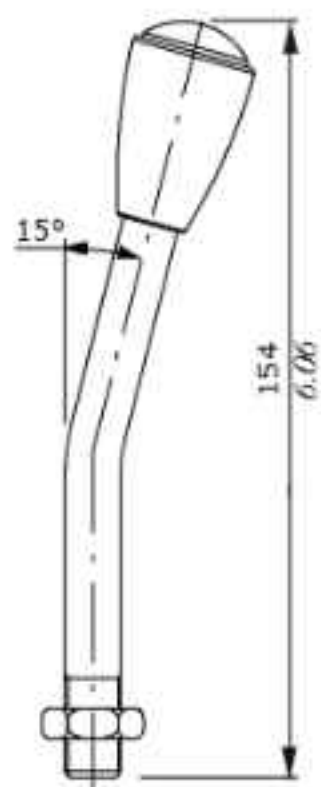

G(30) type
30° sloping rod

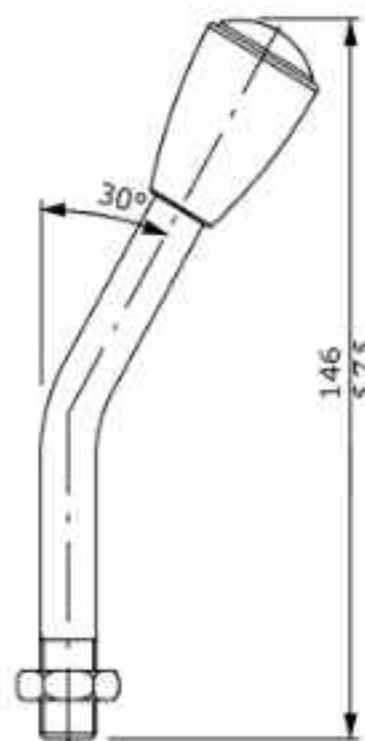

E type
15° sloping rod

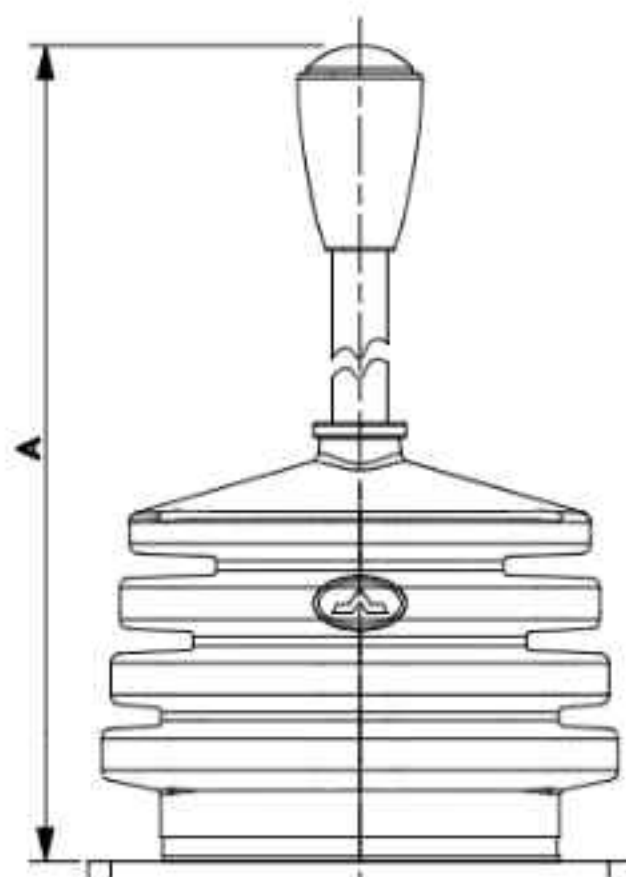
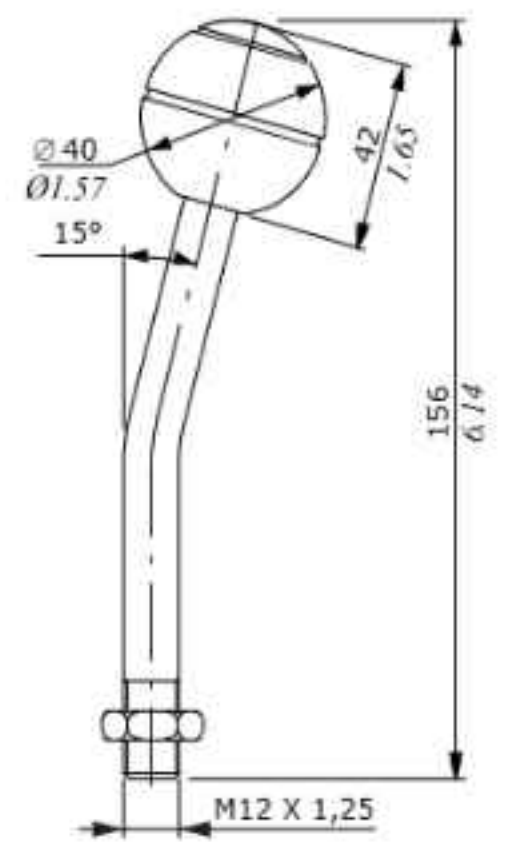

Handlever Type	A	
	mm	in
G3 straight	196	7.72
G3 15° sloping	184	7.24
G3 30° sloping	176	6.23
E 15° sloping	186	7.32

Configuration option

Standard hand levers

Mounting and orientation examples

G type

pilot control valve with 3 sections

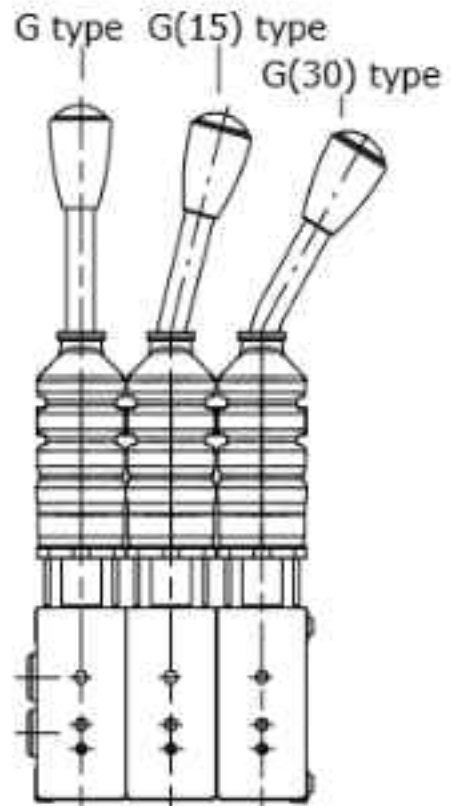

E type

pilot control valve with 2 sections

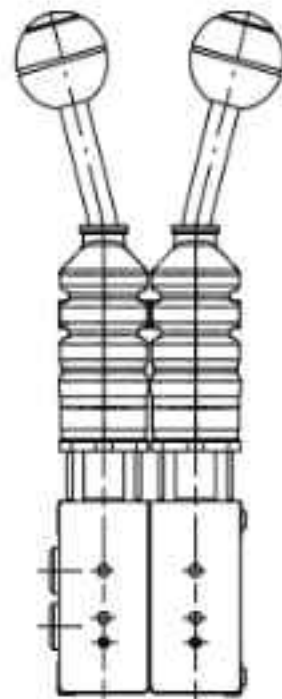

Sloping rod position

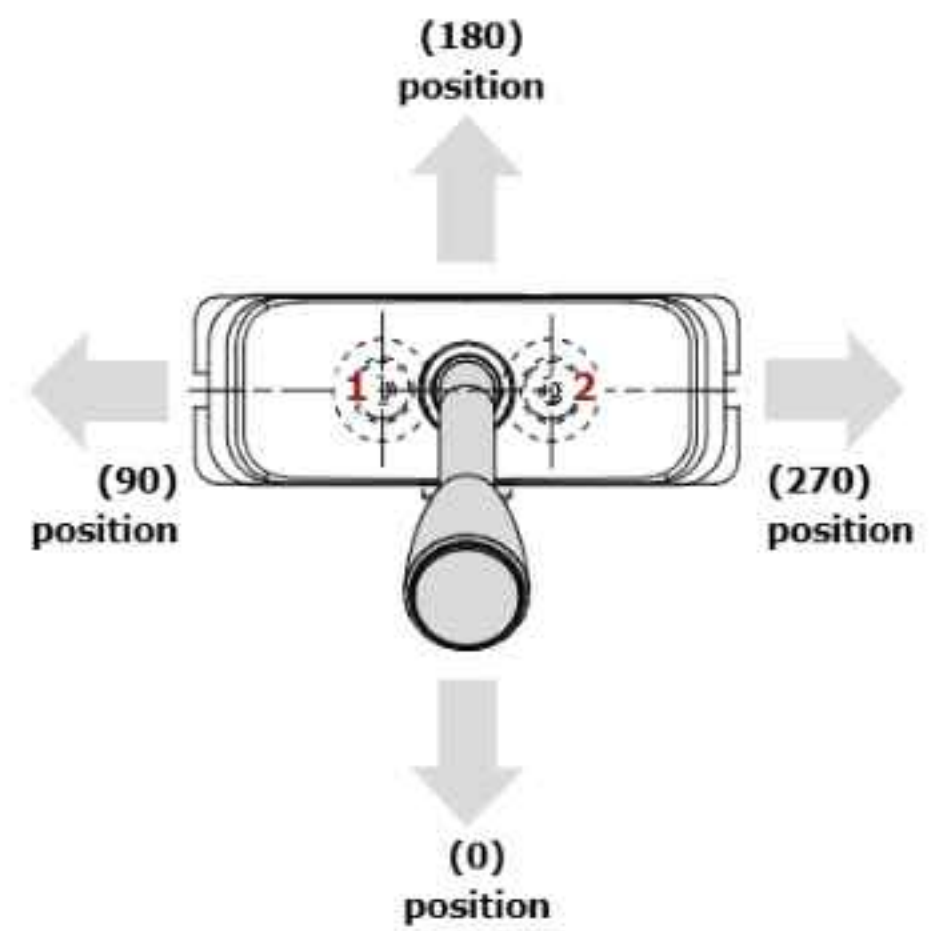

Dimensions and hydraulic circuit

hydraulic circuit
Example detent on working ports 3 e 4

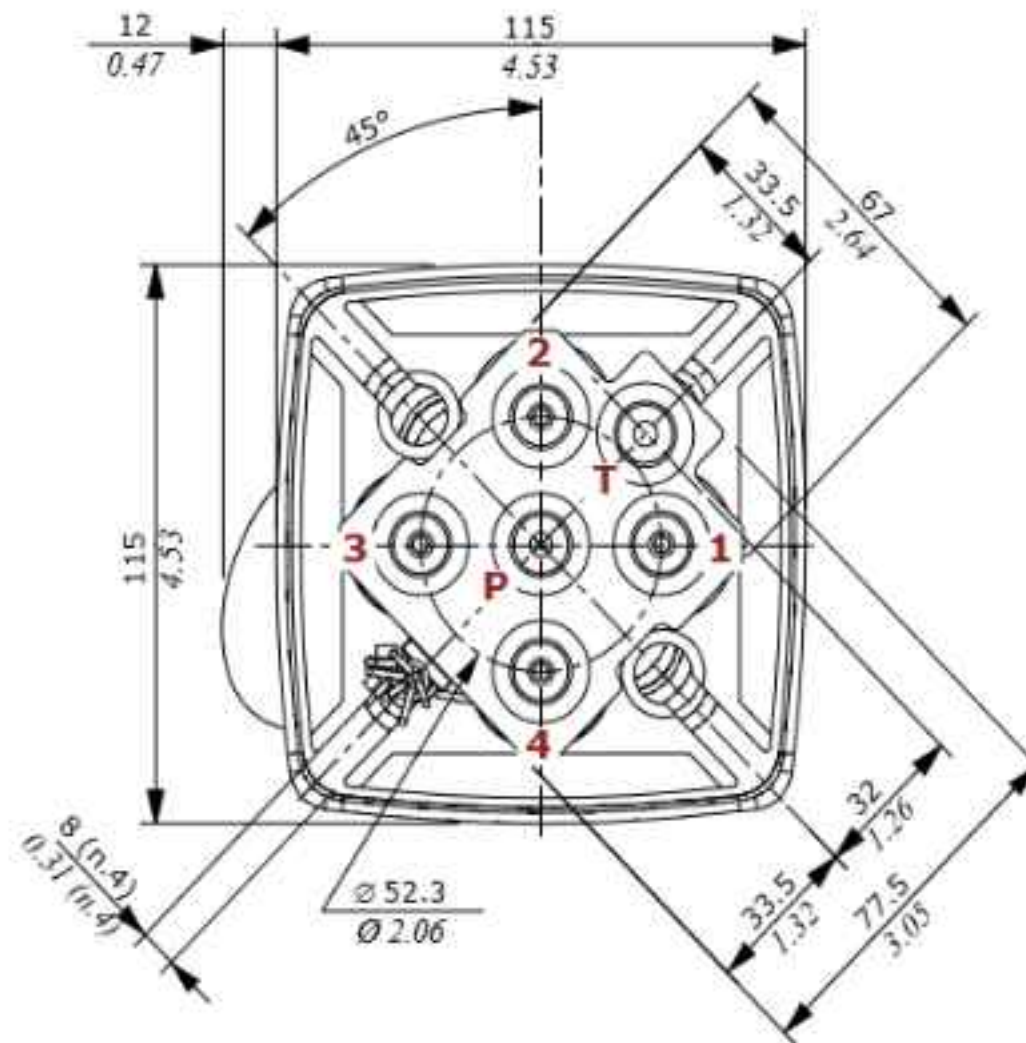
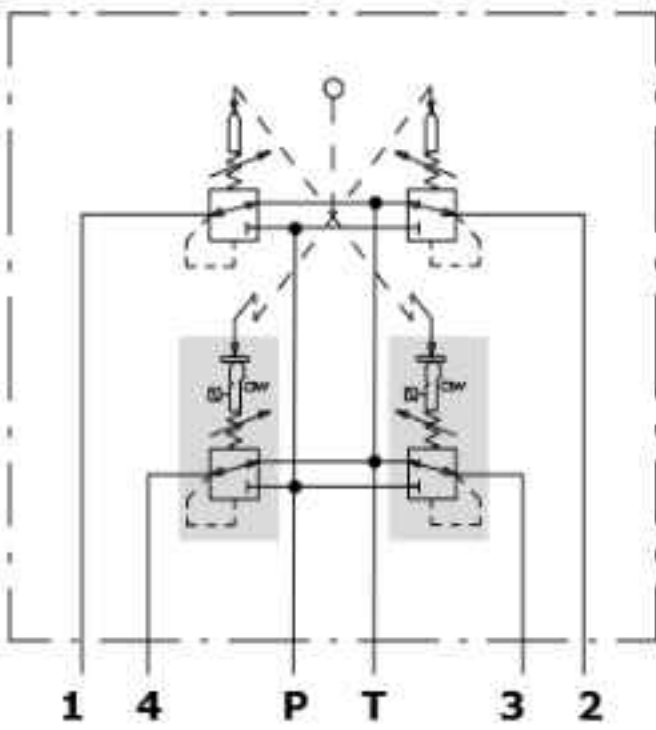

1 : Single work port
2 : Two simultaneous work ports

Features

ELECTROMAGNET

- Nominal voltage tolerance. : ±10%
- Power rating : 8.2 W
- Nominal current : 0.69 A - 12 VDC
: 0.345 A - 24 VDC
- Coil insulation : Class H
- Weather protection : IP65
- Insertion : 100%

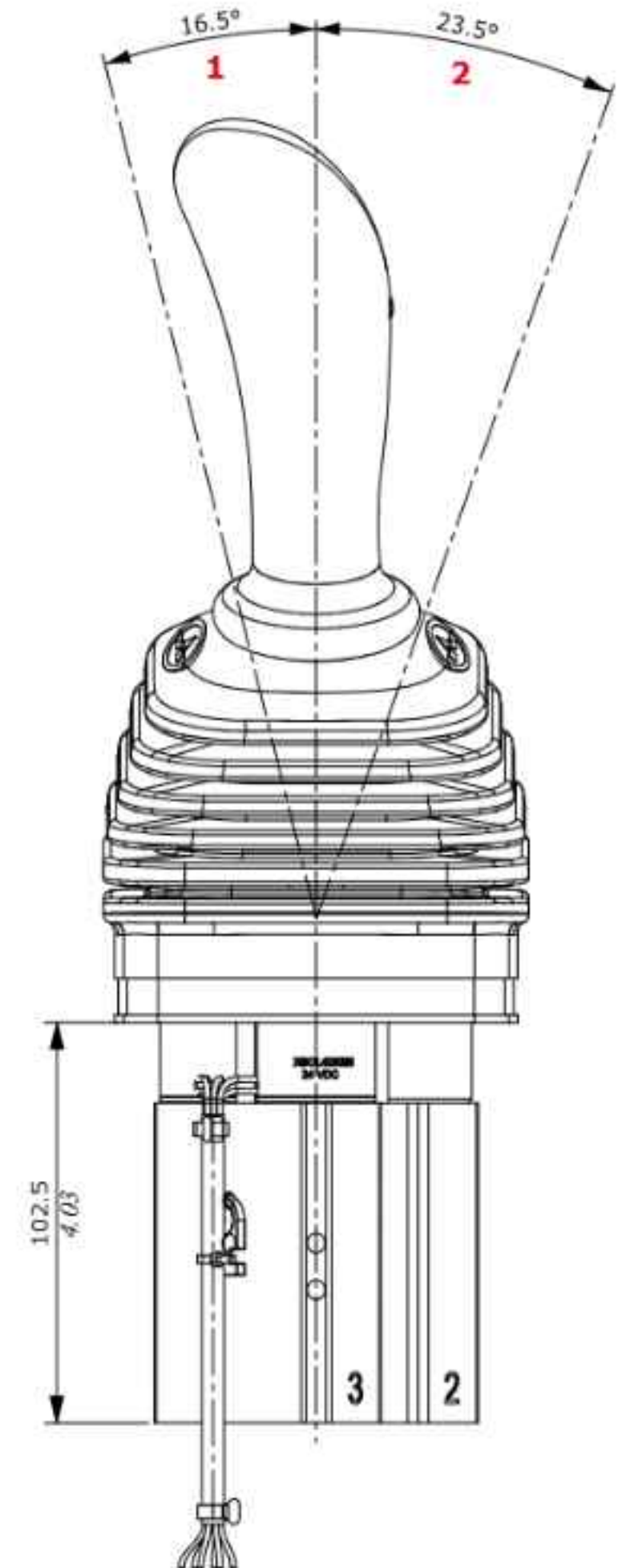
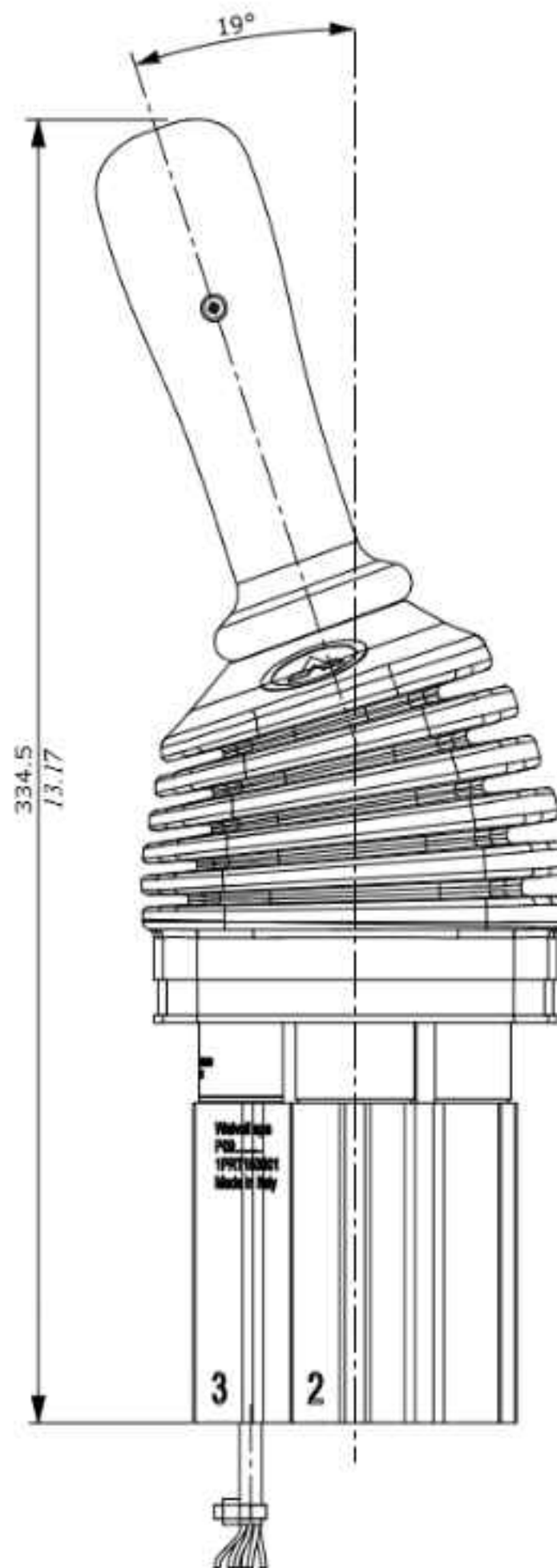

Ordering codes

SVM450-EMD(3-4) / 8N 1 - B / 01N - V007 (....) - A 0 020 M-....-....-E0020NM - (....) - 12VDC

1

2

1

1

3

4

5

6.1

6.2

6.3

6.4

6

6

7

Pressure control curve with electromagnetic detent

Electric devices voltage

Standard pressure control curve

4

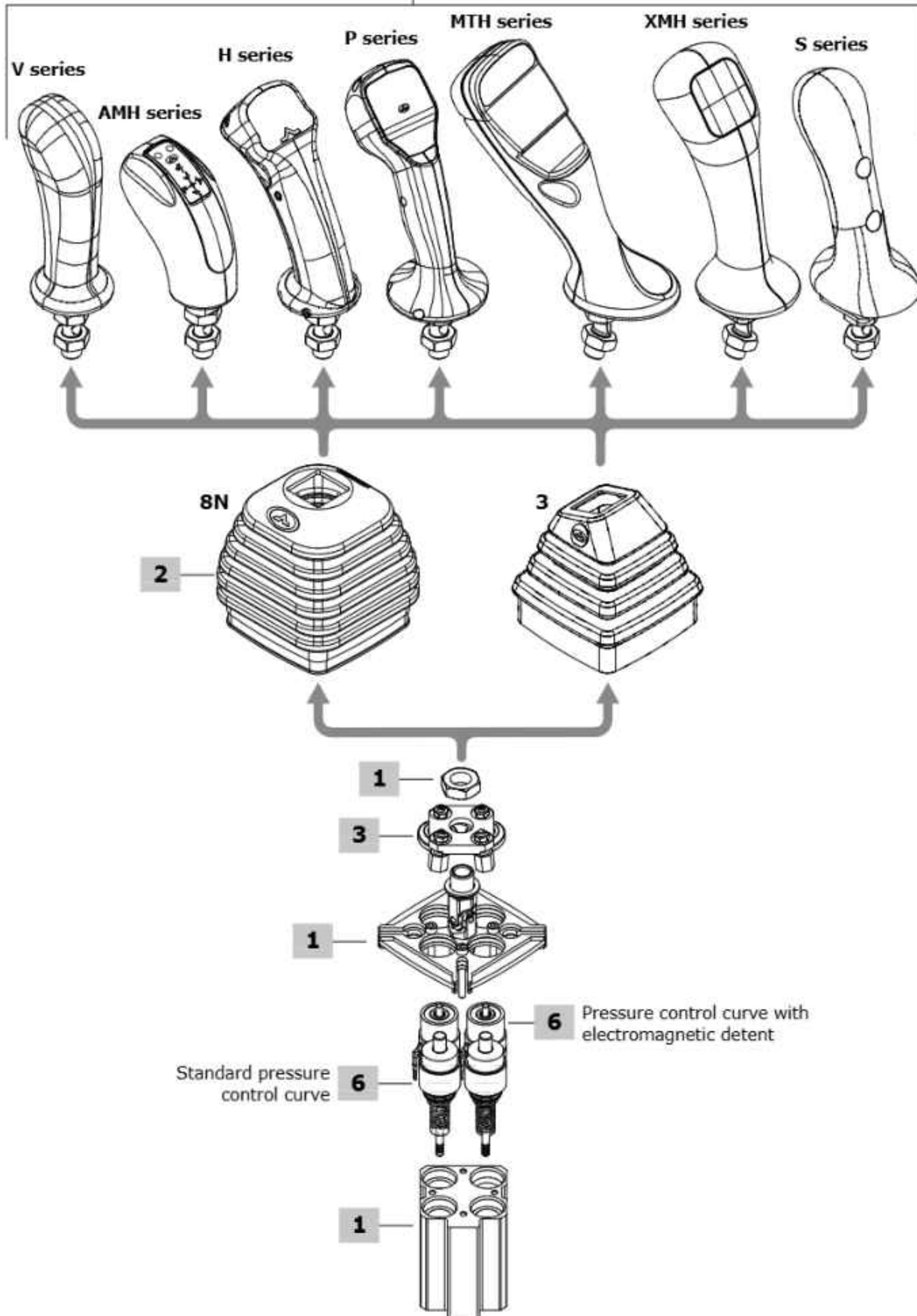

1 Body kit with flange *

TYPE: SVM450-EMD(4)/B	CODE: 5C03450303
DESCRIPTION: With detent arrangement on port 4	
TYPE: SVM450-EMD(3-4)/B	CODE: 5C03450301
DESCRIPTION: With detent arrangement on ports 3 and 4	
TYPE: SVM450-EMD(2-3-4)/B	CODE: 5C03450302
DESCRIPTION: With detent arrangement on ports 2, 3 and 4	

2 Rubber bellow

TYPE	CODE	DESCRIPTION
8N	3SOF115115	Universal type, square base with logo
3	3SOF111111	Sloping type, square base with logo; only for 19° sloping handles

3 Detent configuration**With spring return in neutral position**

TYPE	CODE	DESCRIPTION
01N(1D)	5CIN8011ND	Control kit arranged for 1 detent
01N(2D)	5CIN8012ND	Control kit arranged for 2 detent
01N(3D)	5CIN8013ND	Control kit arranged for 3 detent

NOTE: The text between () can be omitted from description of composition

4 Handles

Some handles as examples are listed below: for technical specifications and full range of handles and other types of joint see the "Handles and handlevers" catalogue.

V series handle

TYPE: V007-(Q) CODE: 5IMP030071
DESCRIPTION: Without switches, with sloping 19° left joint and square seat bellow adapter

AMH series handle

TYPE: AMHT030008-(Q)-6N2D035-7R2D035-8N2D035-(E1)
CODE: 2IM3000007
DESCRIPTION: 3 spring return push-buttons, flying leads, sloping 19° right joint and square seat bellow adapter

H series handle

TYPE: HMB03G-(Q)-1R4040-4R3040-5R2040-(12VDC)
CODE: 2IM4600051
DESCRIPTION: 3 spring return push-buttons on the operator side, flying leads, straight joint, for circular seat bellow

P series handle

TYPE: PZMA1200B7-0R035-3Y2D035-WN130035-ZN130035-(SCHEDA 2PWM)-(TD2M) CODE: 2IM8700003
DESCRIZIONE: 2 proportional roller and 1 spring return push-button on operator side, "dead man" switch, flying leads with Deutsch pins, sloping 19° left joint and square seat bellow adapter

MTH series handle

TYPE: MTH-R00-ZTI4100(K)Y-00-1Y2035-2Y2035-3N2035-6N2035-ZN122035-MRZ035-(5VDC)-D2F12
CODE: 2IM2000005
DESCRIPTION: 1 proportional roller and 4 spring return push-buttons on the operator side, 1 FNR rocker switch on the opposite side, Deutsch connector, sloping 9° left joint and square seat bellow adapter

XMH series handle

TYPE: XMHZTA21008-2G2035-4G2035-7G2035-VG171035
CODE: 2IM1000004
DESCRIPTION: 1 proportional roller and 2 spring return push-buttons on the operator side, 1 push button with spring return on the opposite side, Deutsch connector, 19° sloping right joint, for square seat bellow

S series handle

TYPE: SZTA8-0G4045-XG122045 CODE: 2IM5310003
DESCRIPTION: With proportional roller on the operator side and spring return push-button on the opposite side, 19° sloping right joint, for square seat bellow

5 Handle position

TYPE	DESCRIPTION
(-)	Standard configuration, forward operation to work port 4: omitted in description
(90)	Mounted with 90° rotation step: forward operation towards port 1
(180)	Mounted with 180° rotation step: forward operation towards port 2
(270)	Mounted with 270° rotation step: forward operation towards port 3

6 Pressure control curves

For list available see from page 63

6.1 Curve type

TYPE	DESCRIPTION
A	Without pre-feeling, without solenoid
B	With pre-feeling, without solenoid
C	With solenoid 24VDC and pre-feeling
D	With solenoid 24VDC, without pre-feeling
E	With solenoid 12VDC, with pre-feeling
F	With solenoid 12VDC, without pre-feeling
G	With solenoid 24VDC and pre-feeling after step

6.2 Typology of curves

TYPE	DESCRIPTION
0	With step
1	Without step

6.3 Curve identification

Progressive number

6.4 Return springs

TYPE	DESCRIPTION
M	Operation range from 18 to 25.5 N - <i>from 4.04 to 5.73 lbf</i>
A	Operation range from 23 to 35.2 N - <i>from 5.17 to 7.91 lbf</i>

7 Connector

Configurations with detent or microswitch are provided with wires with tin-plate terminals. For connectors please contact our Sales Department.

NOTE (*) - Codes are referred to BSP thread.

Configuration option

Handle option

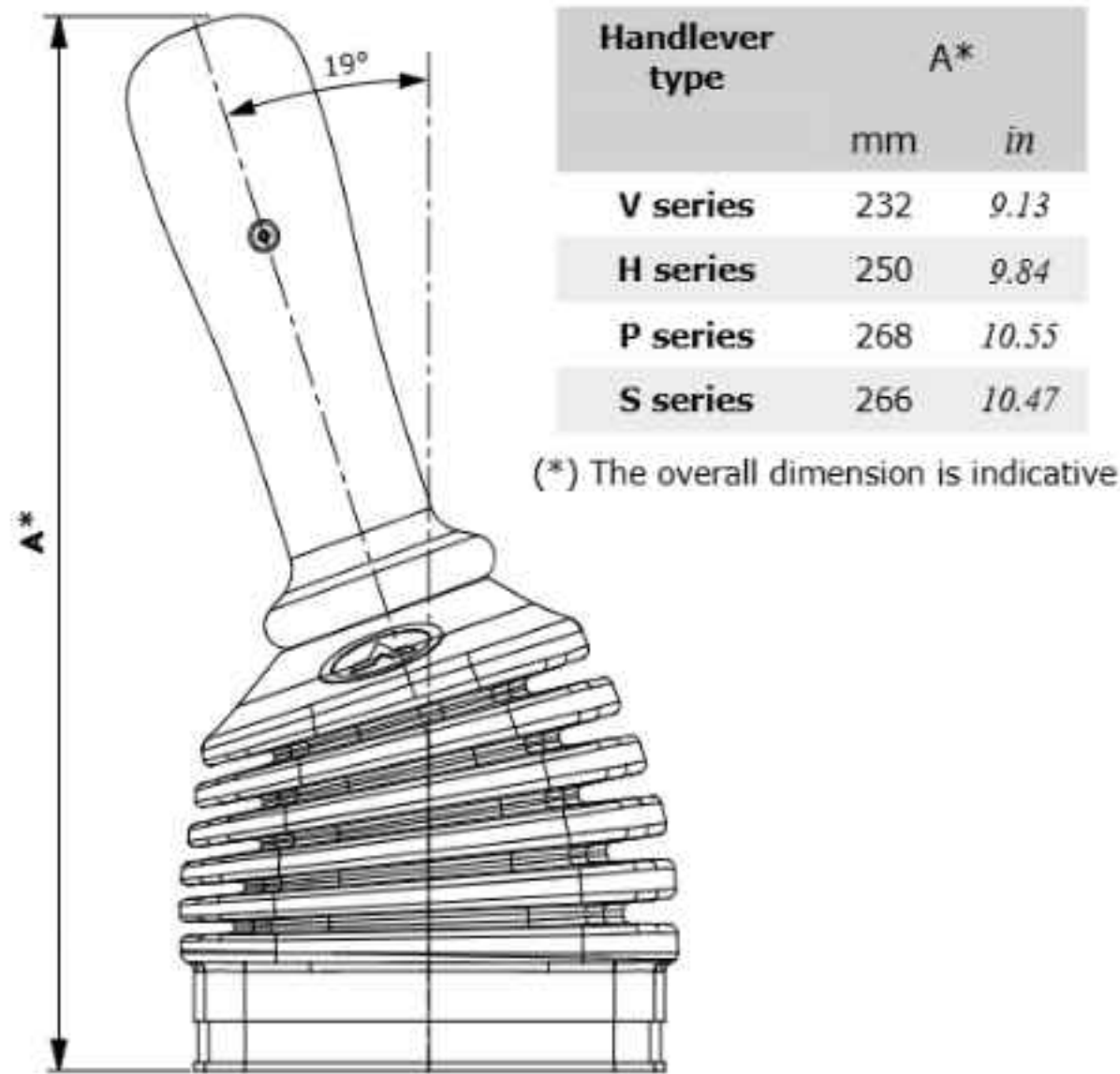

Handle positions

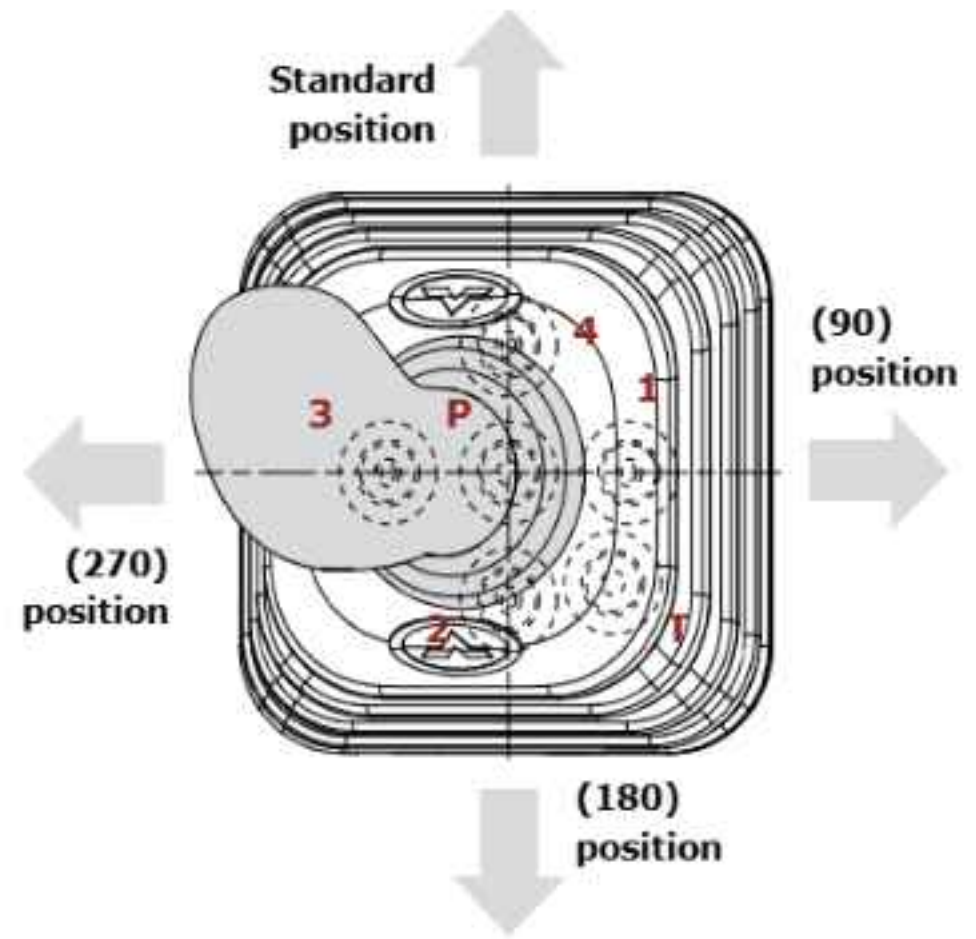

Detent configuration

01/2D type

Detent on ports 3 and 4, with spring return

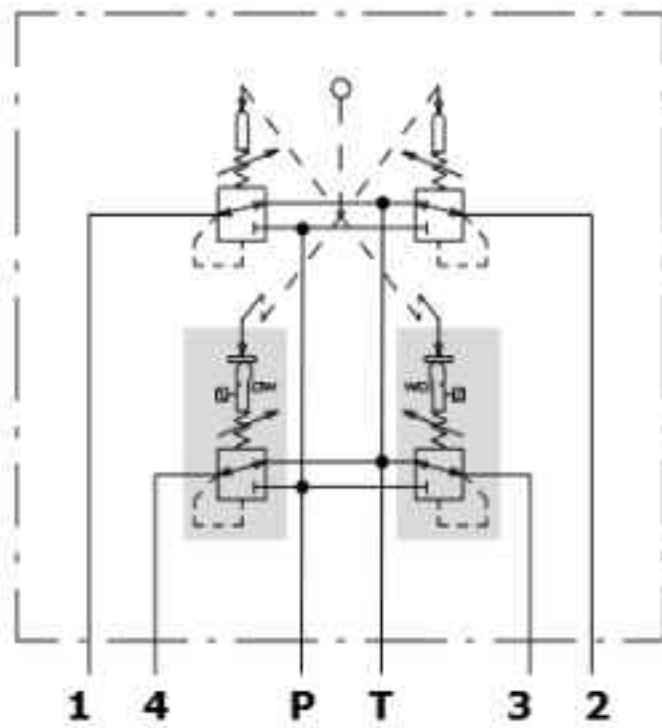

01/3D type

Detent on ports 2, 3 and 4 with spring return

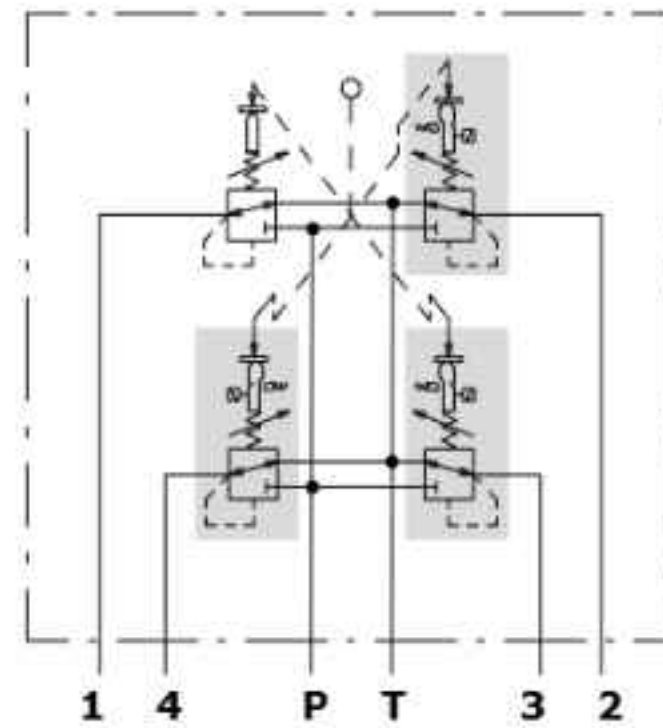

Dimensions and circuit hydraulic

Hydraulic circuit

Example detent on working ports 3, 4 and 6

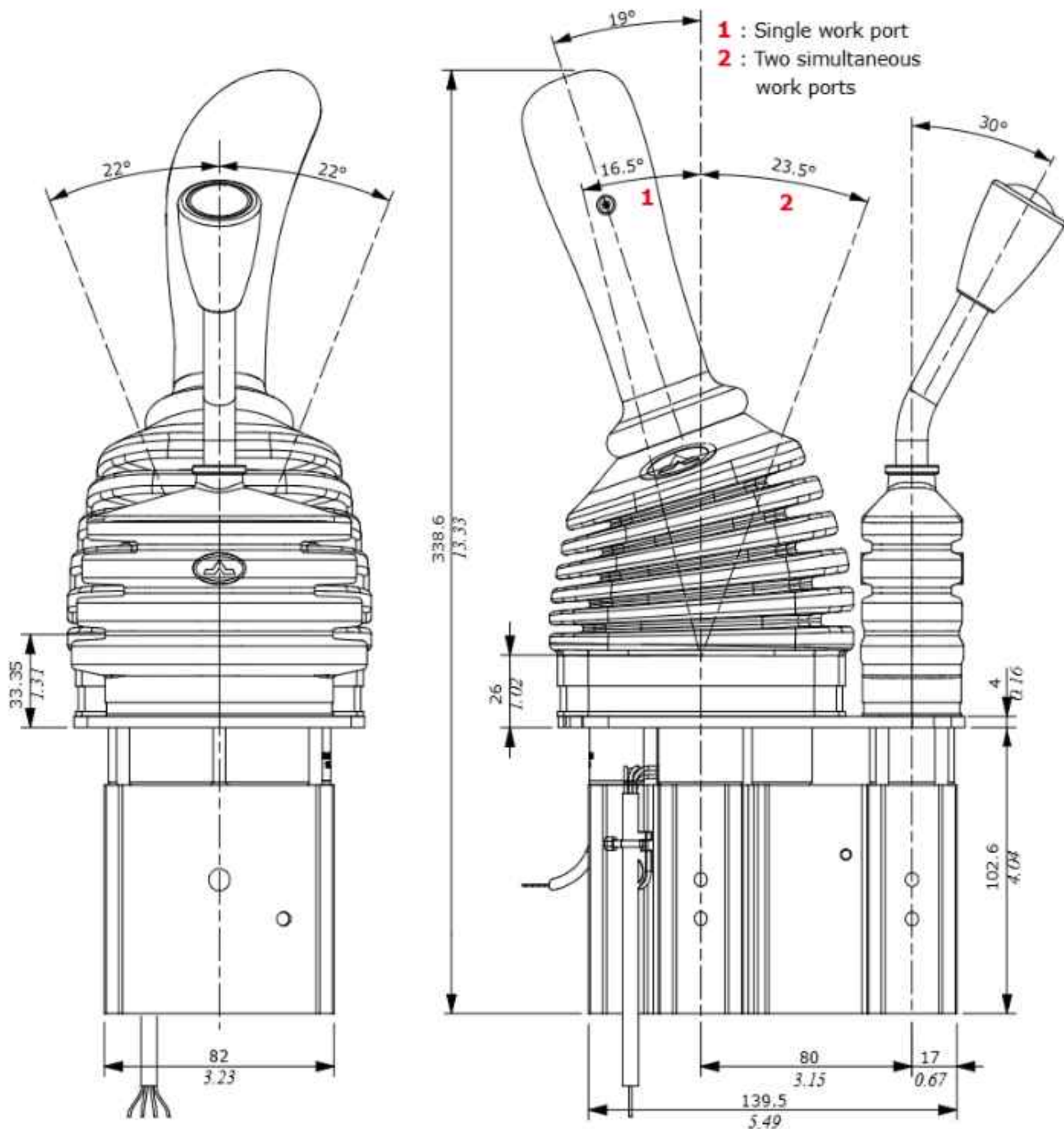
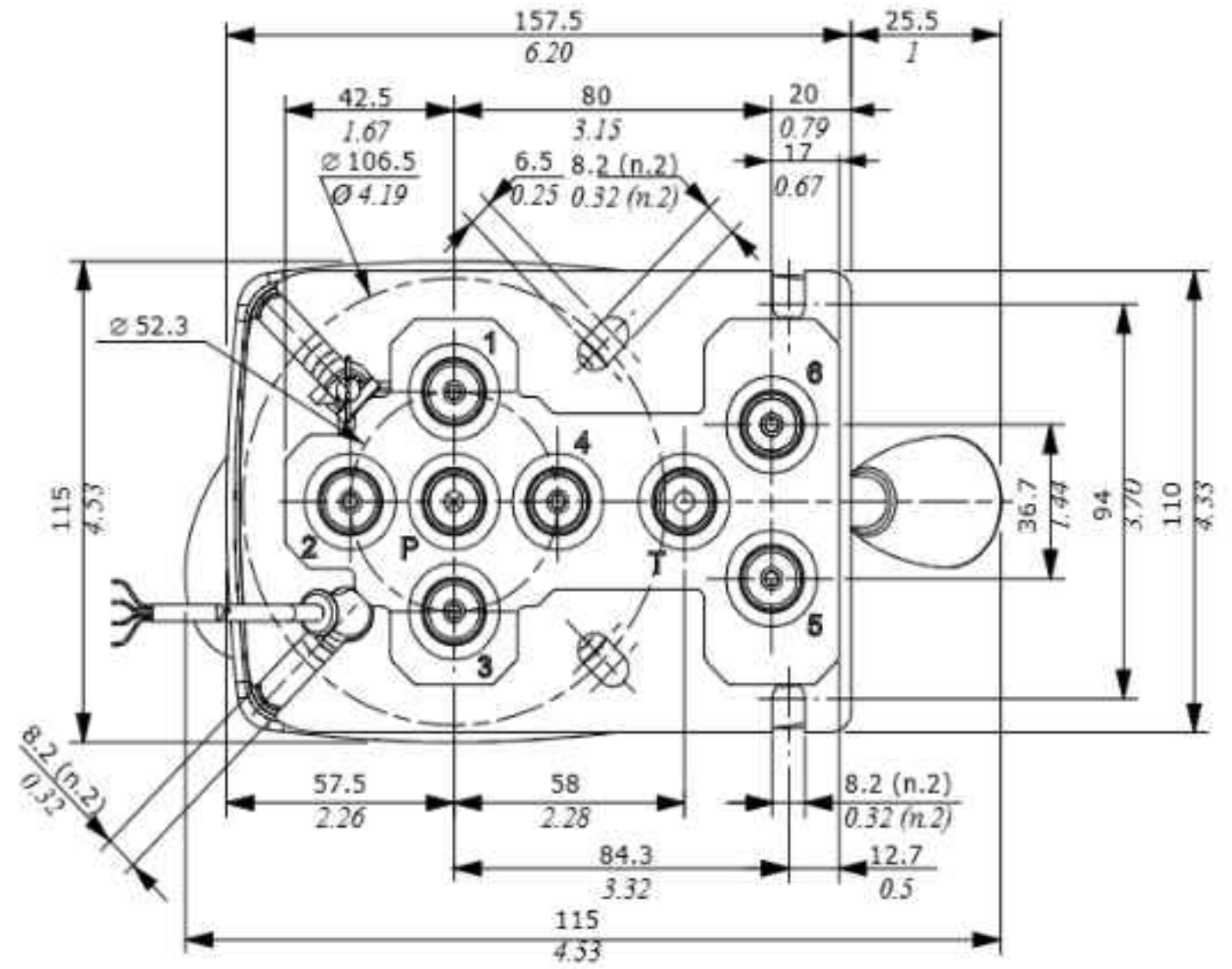
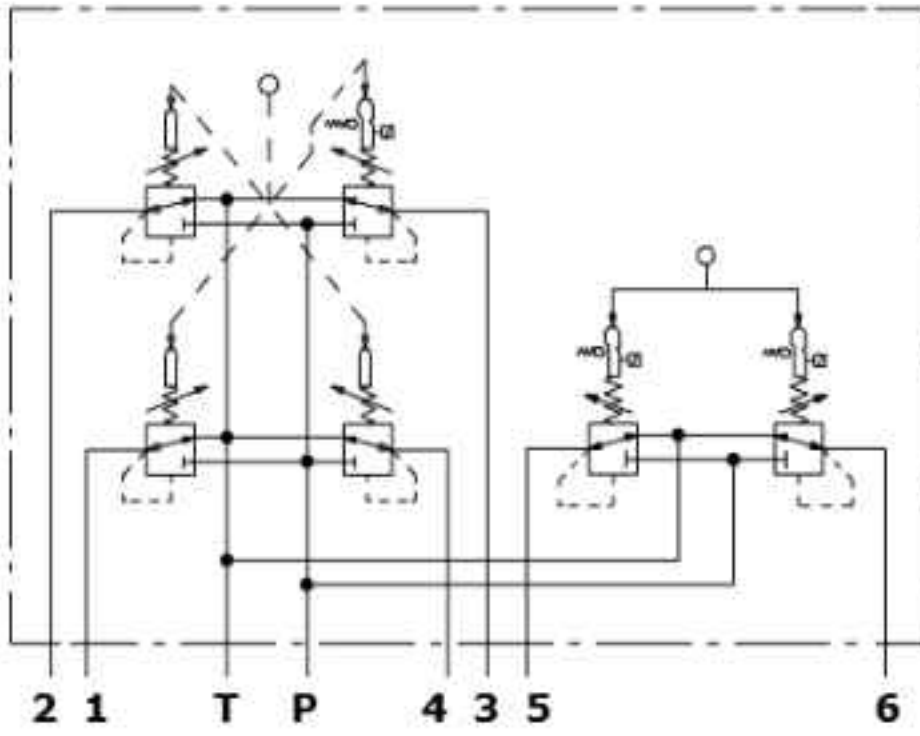

Ordering codes

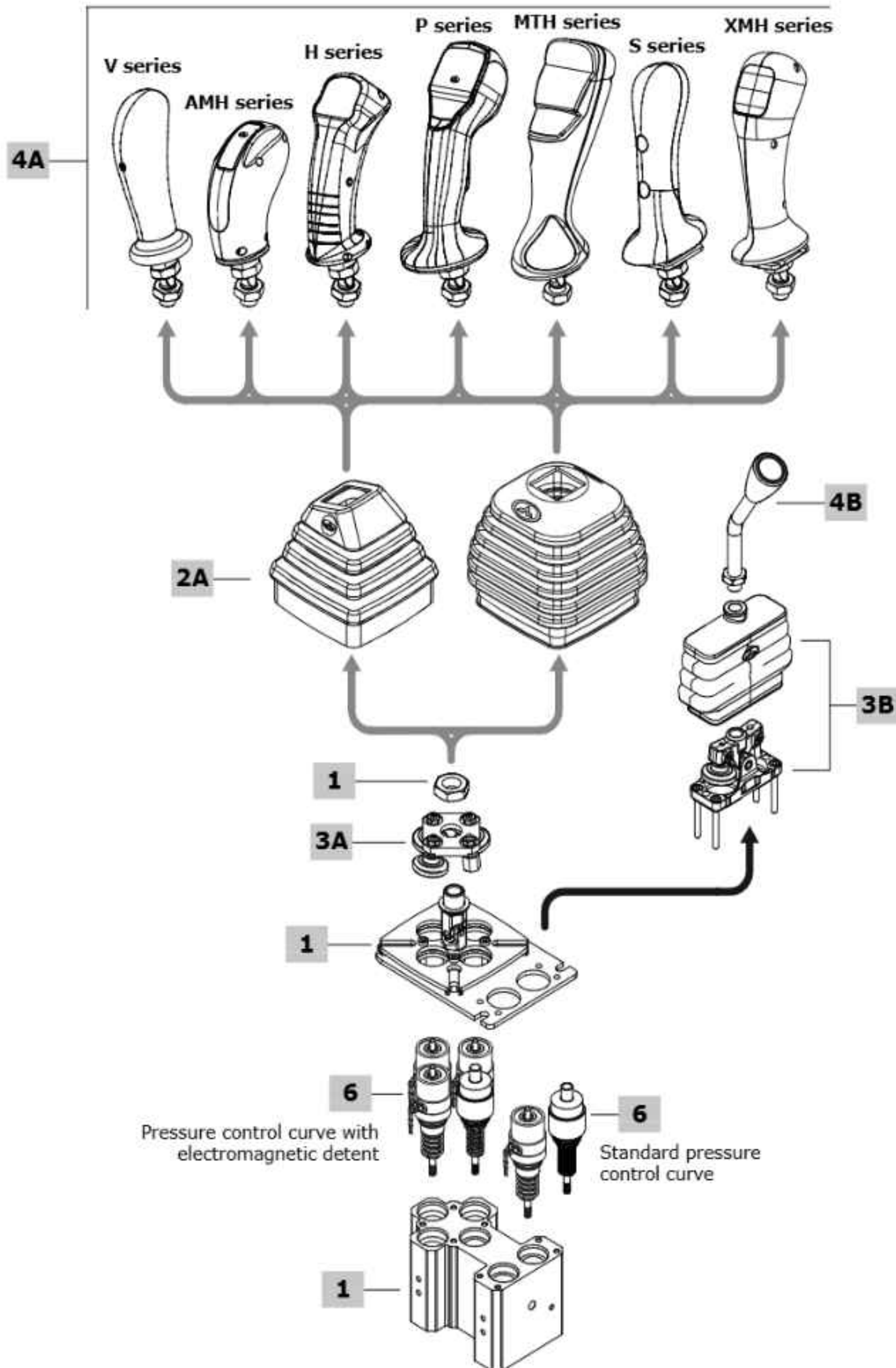
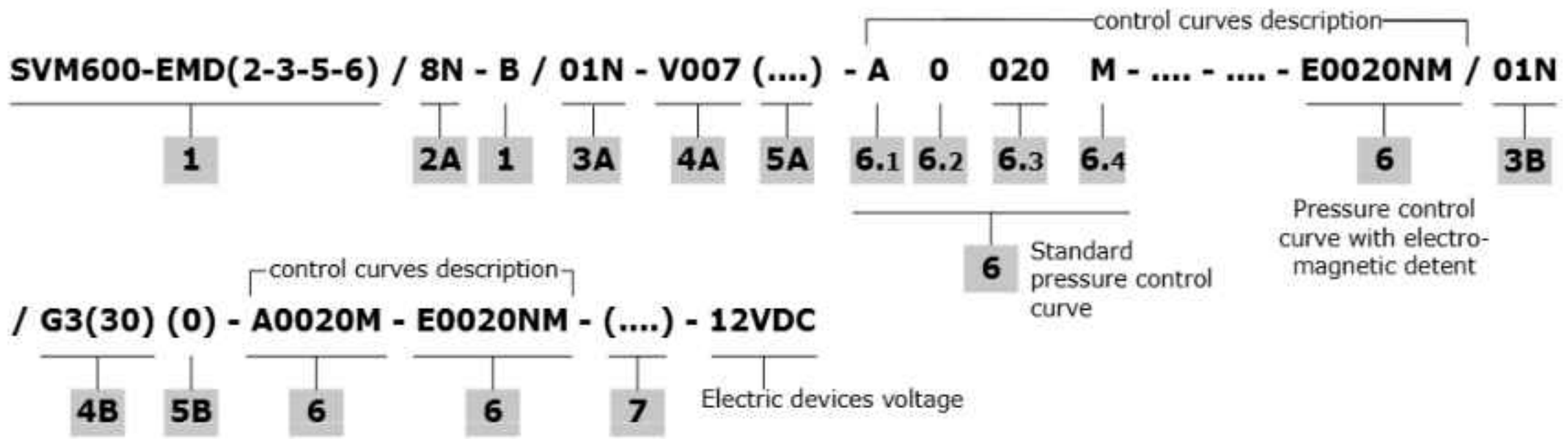

Main options

1 Body kit with flange *

TYPE: SVM600-EMD(2-3)/B	CODE: 5C03600300
DESCRIPTION: With detent arrangement on ports 2 and 3	
TYPE: SVM600-EMD(1-2-3)/B	CODE: 5C03600301
DESCRIPTION: With detent arrangement on ports 1, 2 and 3	
TYPE: SVM600-EMD(2-3-6)/B	CODE: 5C03600302
DESCRIPTION: With detent arrangement on ports 2, 3 and 6	
TYPE: SVM600-EMD(1-2-3-6)/B	CODE: 5C03600303
DESCRIPTION: With detent arrangement on ports 1, 2, 3 and 6	

6 Pressure control curves

For list available see from page 63

6.1 Curve type

TYPE	DESCRIPTION
A	Without pre-feeling, without solenoid
B	With pre-feeling, without solenoid
C	With solenoid 24VDC and pre-feeling
D	With solenoid 24VDC, without pre-feeling
E	With solenoid 12VDC, with pre-feeling
F	With solenoid 12VDC, without pre-feeling
G	With solenoid 24VDC and pre-feeling after step

6.2 Typology of curves

TYPE	DESCRIPTION
0	With step
1	Without step

6.3 Curve identification

Progressive number

6.4 Return springs

TYPE	DESCRIPTION
M	Operation range from 18 to 25.5 N - <i>from 4.04 to 5.73 lbf</i>
A	Operation range from 23 to 35.2 N - <i>from 5.17 to 7.91 lbf</i>

7 Connector

Configurations with detent or microswitch are provided with wires with tin-plate terminals. For connectors please contact our Sales Department.

Joystick options

2A Rubber bellow

TYPE	CODE	DESCRIPTION
8N	3SOF115115	Universal type, square base with logo
3	3SOF111111	Sloping type, square base with logo; only for 19° sloping handles

3A Detent configuration**With spring return in neutral position**

TYPE	CODE	DESCRIPTION
01N(2D)	5CIN8012ND	Control kit arranged for 2 detents
01N(3D)	5CIN8013ND	Control kit arranged for 3 detents

NOTE: The text between () is omitted from description of composition

4A Handles

Some handles as examples are listed below: for technical specifications and full range of handles and other types of joint see the "Handles and hand levers" catalogue.

V series handle

TYPE: V007-(Q)	CODE: 5IMP030071
DESCRIPTION: Without switches, with sloping 19° left joint and square seat bellow adapter	

S series handle

TYPE: SZTA8-0G4045-XG122045	CODE: 2IM5310003
DESCRIPTION: With proportional roller on the operator side and spring return push-button on the opposite side, 19° sloping right joint, for square seat bellow	

5A Handle position

TYPE	DESCRIPTION
(-)	Standard configuration, forward operation toward port 4: omitted in description
(180)	Mounted with 180° rotation step: forward operation towards port 2
(270)	Mounted with 270° rotation step: forward operation towards port 3

Single acting options

3B Control option

Complete with rubber bellow (code 3SOF190783-C) and fixing wrapper

TYPE	CODE	DESCRIPTION
01N(0D)	5CIN1010DN	Spring return to neutral position, without detent arrangement
01N(1D)	5CIN1011DN	Spring return to neutral position, single detent arrangement; right or left position is defined by pressure control curve position
01N(2D)	5CIN1012DN	Spring return to neutral position, double detent arrangement

NOTE: The text between () is omitted from description of composition

4B Standard hand lever

TYPE	CODE	DESCRIPTION
G3(30)	5AST371228G	Ogival with portlight, 30° bending rod For features see page 42

5B Handle position

TYPE	DESCRIPTION
(0)	Hand lever oriented on P and T plugged ports
(90)	Hand lever oriented towards port 5
(270)	Hand lever oriented towards port 6

For different positions, please contact our Sales Department.

NNOTE (*) – Codes are referred to BSP thread.

Configuration option

Handle options

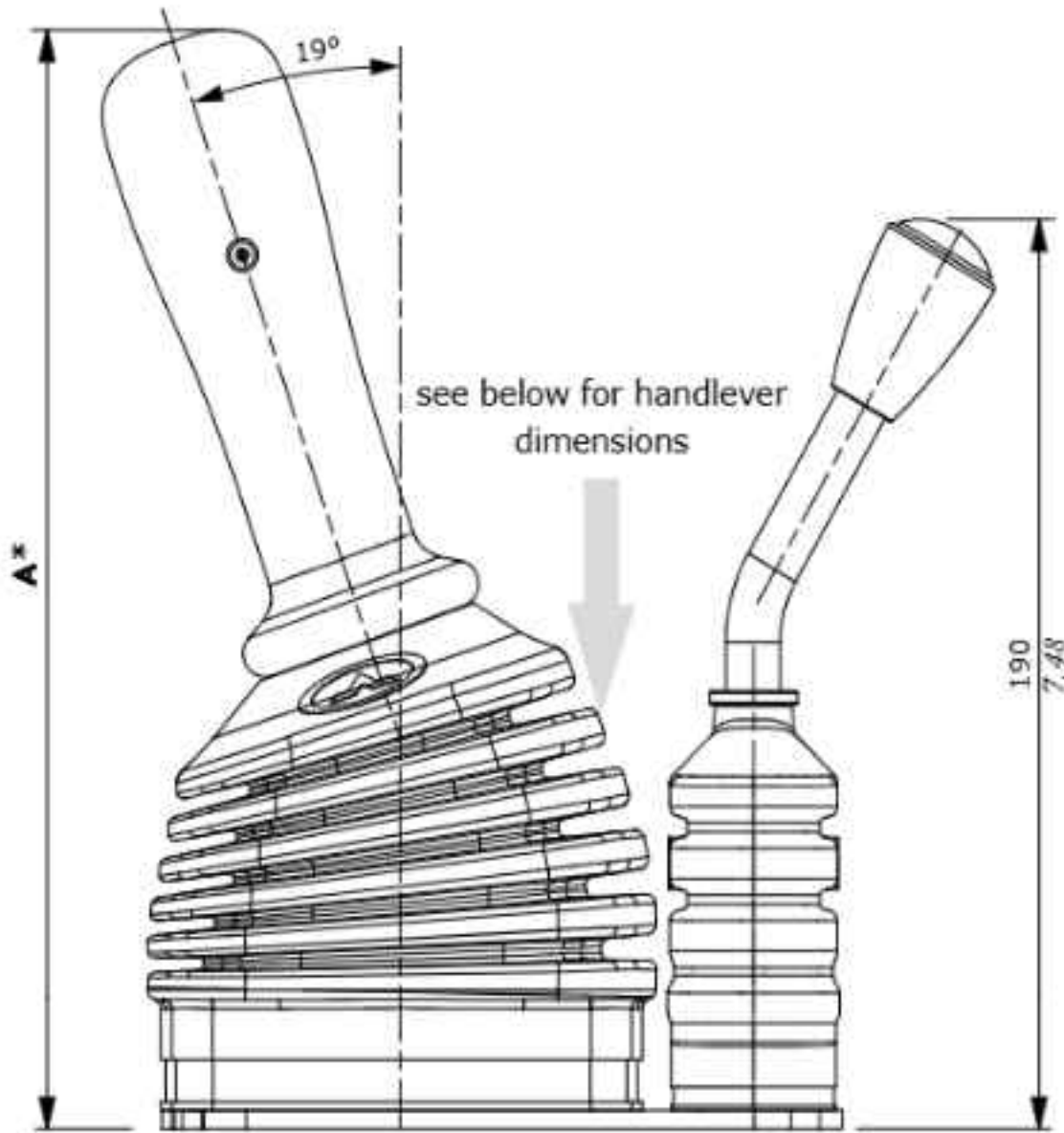

Handle and handle lever positions

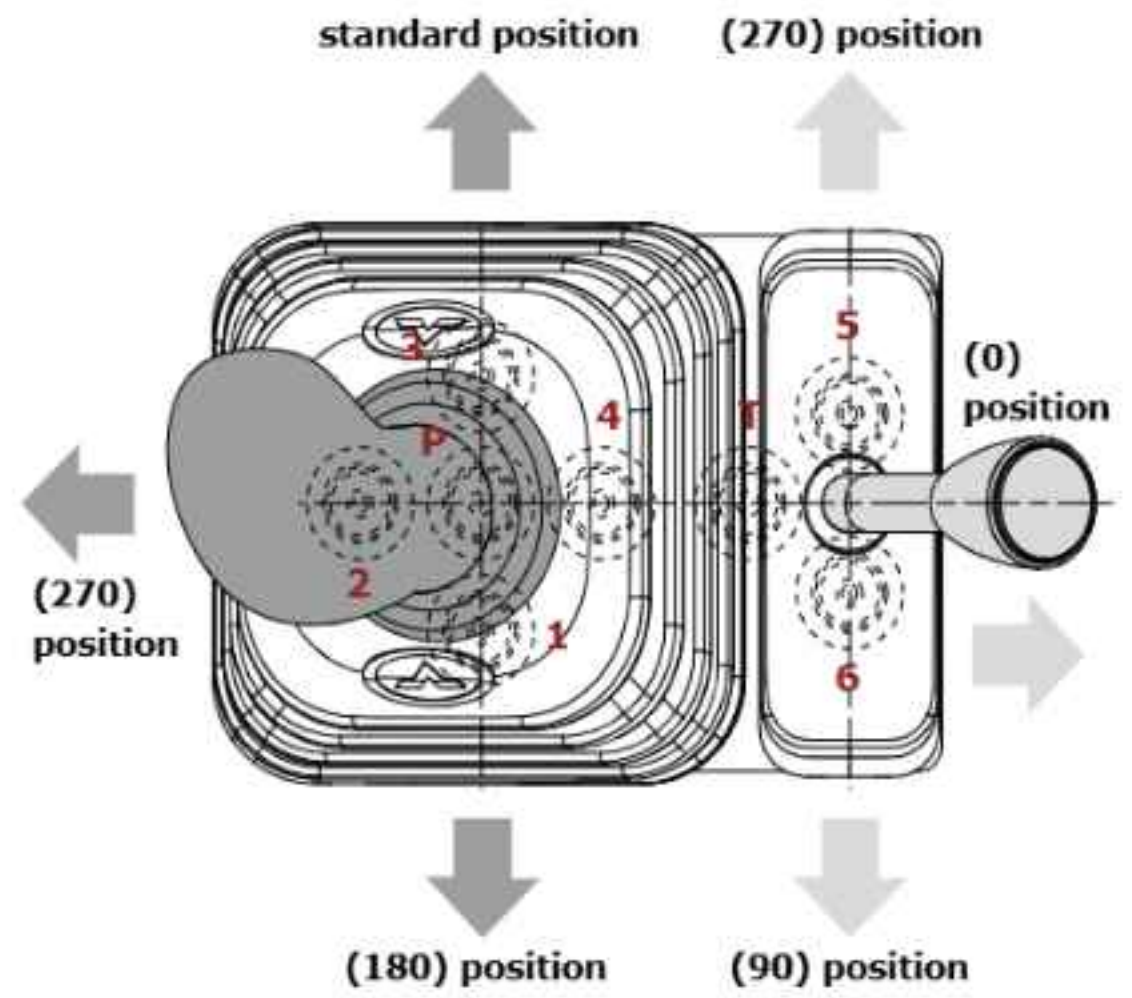

Handlever type	A*	
	mm	in
V series	232	9.13
H series	250	9.84
P series	268	10.55
S series	266	10.47

(*) The overall dimension is indicative

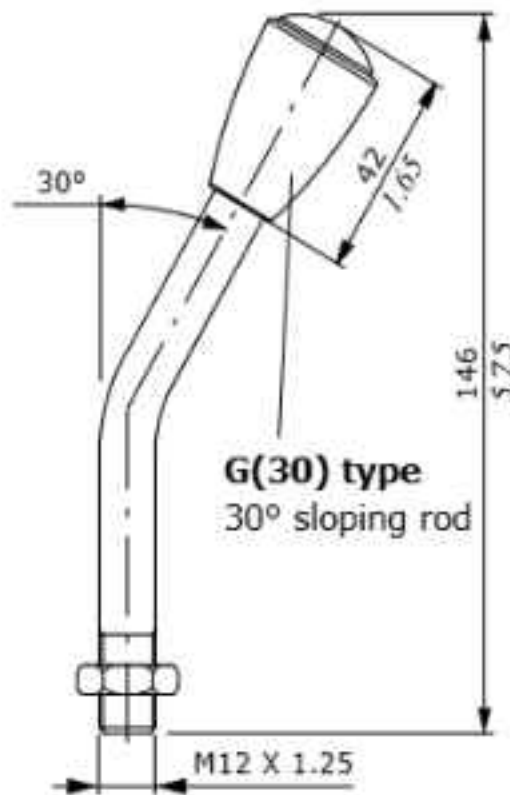

Detent configuration: examples

01/2D type (joystick)

Detent on ports 2 and 3, with spring return

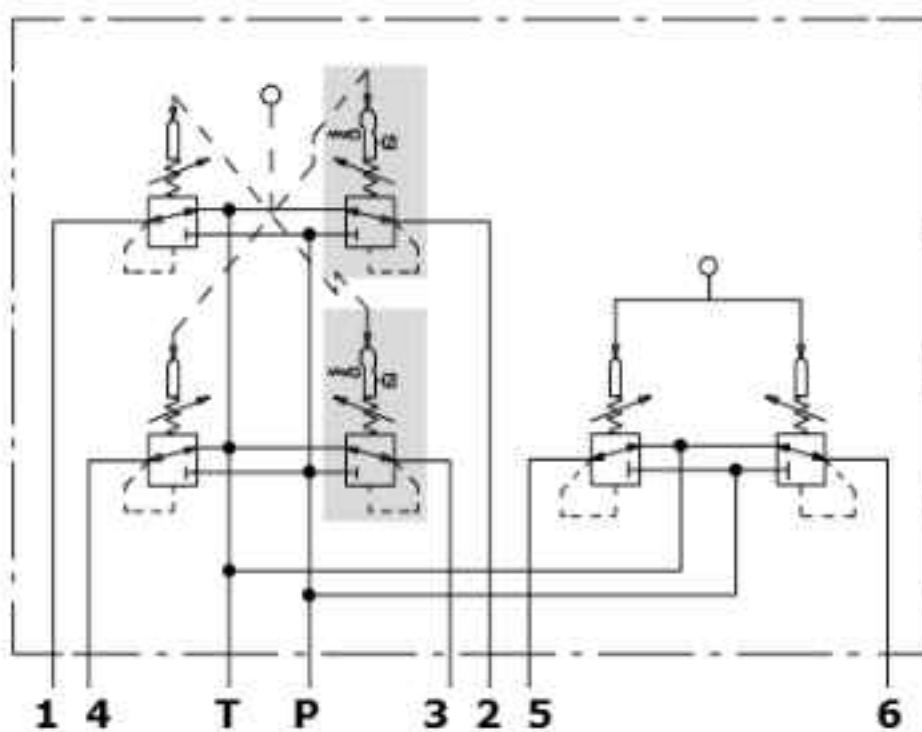

01/3D type (joystick) + 01/1D (single acting)

Detent on ports 1, 2, 3 and 6, with spring return

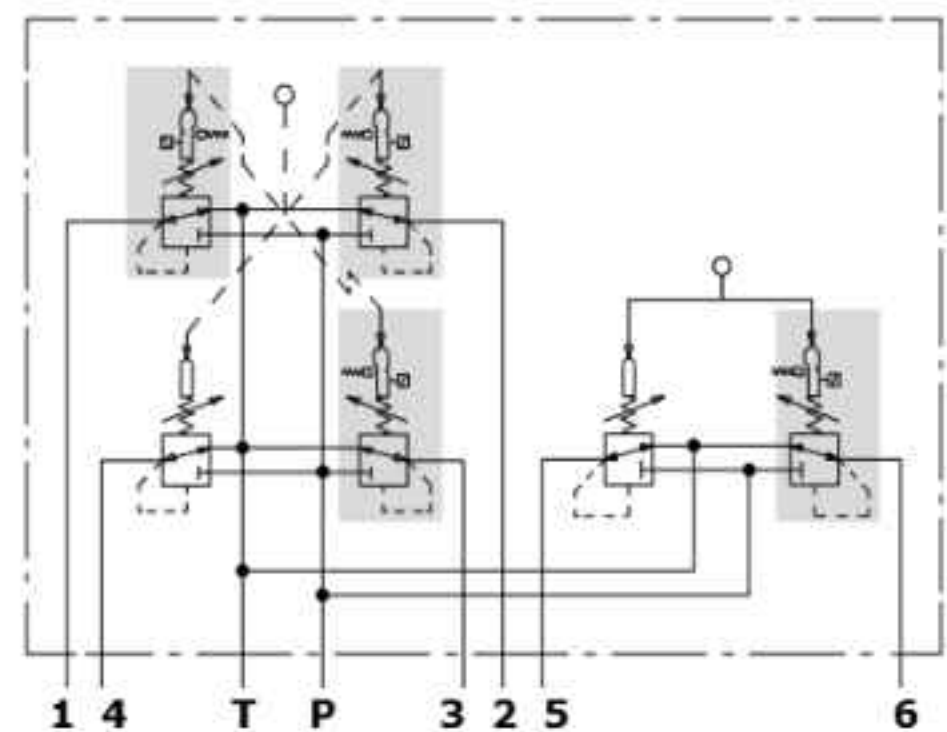

Control curves with step

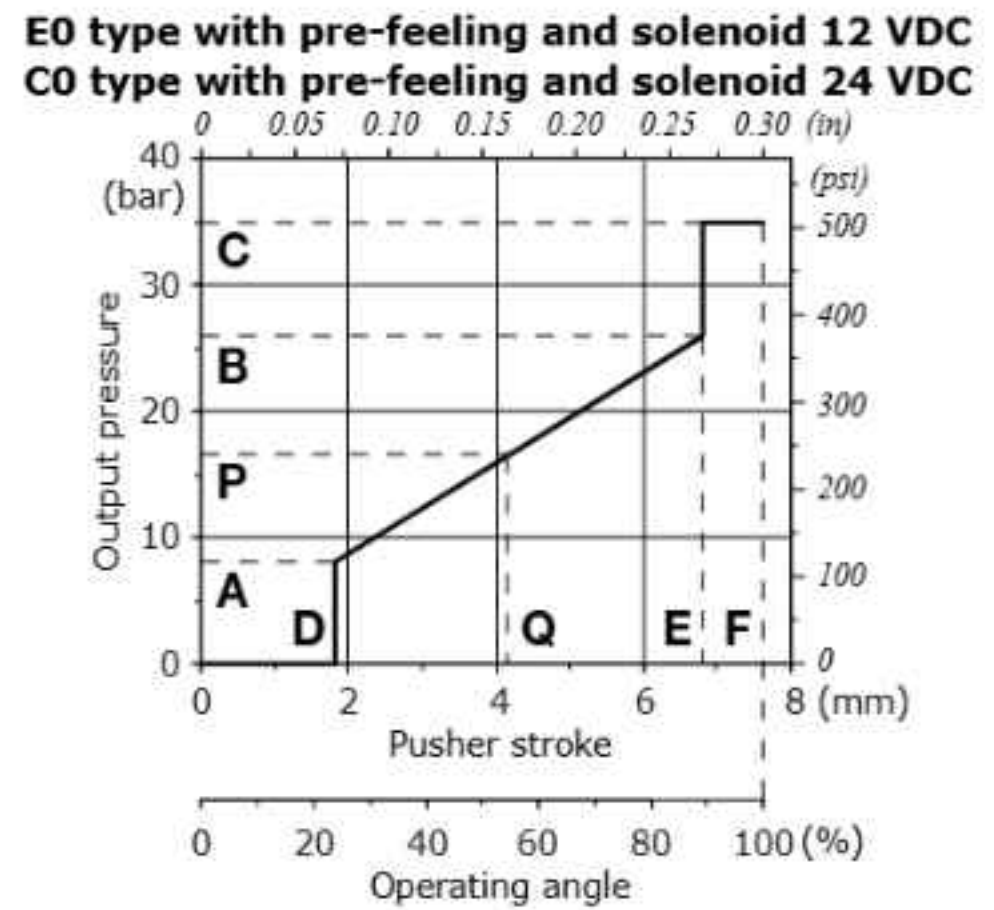
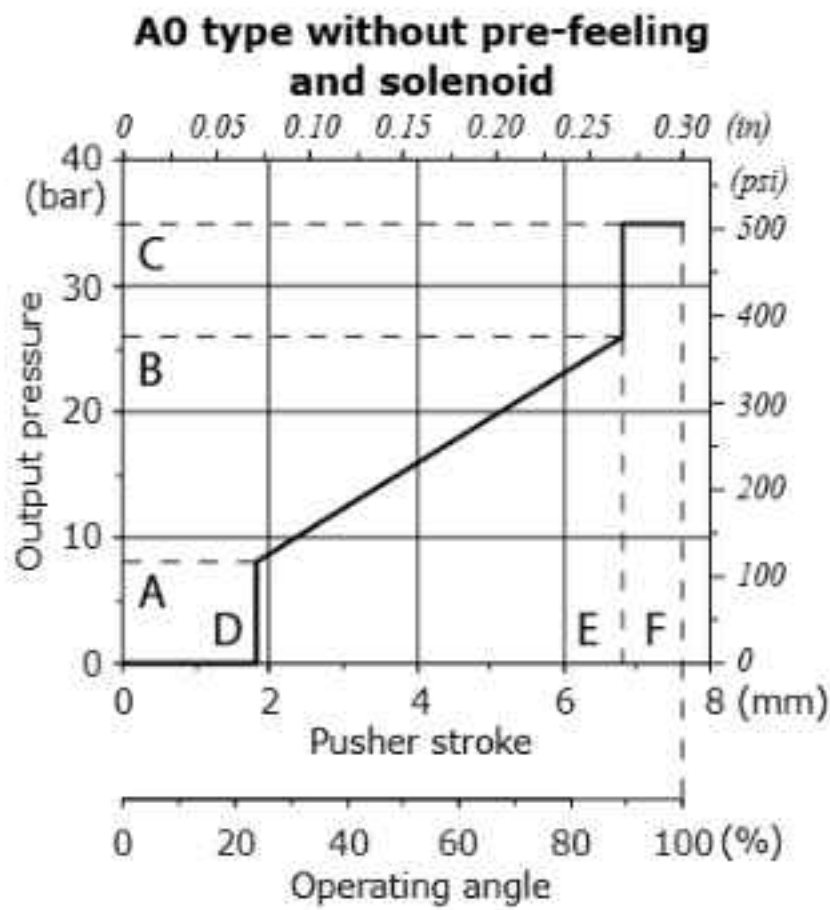

Curve description		Pressure						Stroke						CODE ⁽¹⁾				
Type	Nr	A		P		B		C		D		Q			E		F	
		bar (±toll)	psi (±toll)	bar (±toll)	psi (±toll)	bar (±toll)	psi (±toll)	bar	psi	mm (in)	mm (in)	mm (in)	mm (in)	mm (in)	mm (in)	mm (in)	mm (in)	
A0	011	3.5 (±1)	50.7 (±14.5)			25 (±1.5)	362.5 (±21.7)	35	507.5	0.85	0.03			7.25	0.28	7.6	0.30	5CR7A0011M
A0	099	3.6 (±1)	52.2 (±14.5)			15.8 (±1)	229.1 (±14.5)	35	507.5	0.85	0.03			7.25	0.28	7.6	0.30	5CR7A0099M
A0	B47	3.8 (±1)	55.1 (±14.5)			16.7 (±1)	242.15 (±14.5)	35	507.5	0.85	0.03			7.25	0.28	7.6	0.30	5CR7A0B47M
A0	086	4 (±1)	58 (±14.5)			16.5 (±1)	239.2 (±14.5)	35	507.5	0.85	0.03			7.25	0.28	7.6	0.30	5CR7A0086M
A0	020	4.3 (±0.5)	62.3 (±7.25)			15.2 (±1.5)	220.4 (±21.7)	35	507.5	0.85	0.03			7.25	0.28	7.6	0.30	5CR7A0020M
A0	028	5 (±1)	72.5 (±14.5)			21 (±1.5)	304.5 (±21.7)	35	507.5	0.85	0.03			7.25	0.28	7.6	0.30	5CR7A0028M
A0	075	5 (±0.5)	72.5 (±7.25)			15 (±1.5)	22.5 (±21.7)	35	507.5	0.85	0.03			7.25	0.28	7.6	0.30	5CR7A0075A
A0	077	5 (±1)	72.5 (±14.5)			27 (±2)	391.5 (±29)	35	507.5	0.85	0.03			7.25	0.28	7.6	0.30	5CR7A0077M
A0	119	5 (±1)	72.5 (±14.5)			23.5 (±2)	340.7 (±29)	35	507.5	0.85	0.03			7.25	0.28	7.6	0.30	5CR7A0119M
A0	001	5.8 (±0.5)	84.1 (±7.25)			22 (±1.5)	319 (±21.7)	30	435	0.85	0.03			7.25	0.28	7.6	0.30	5CR7A0001M
A0	033	5.8 (±0.5)	84.1 (±7.25)			19.1 (±1)	276.9 (±14.5)	35	507.5	0.85	0.03			7.25	0.28	7.6	0.30	5CR7A0033B
A0	085	6 (±1)	87 (±14.5)			25 (±1.5)	362.5 (±21.7)	35	507.5	0.85	0.03			7.25	0.28	7.6	0.30	5CR7A0085A
A0	088	8 (±0.5)	116 (±7.25)			27 (±1.5)	391.5 (±21.7)	35	507.5	0.85	0.03			7.25	0.28	7.6	0.30	5CR7A0088M
A0	036	12 (±0.5)	174 (±7.25)			25 (±1)	362.5 (±14.5)	35	507.5	0.85	0.03			7.25	0.28	7.6	0.30	5CR7A0036A
With Pre-feeling for electromagnetic detent																		
C0	B09	3.5 (±0.5)	50.7 (±7.25)	13.7 (±1)	198.6 (±14.5)	15.1 (±1)	218.9 (±14.5)	35	507.5	0.85	0.03	6.5	0.25	7.25	0.28	7.6	0.30	5CR7C0B09NM
E0	B09	3.5 (±0.5)	50.7 (±7.25)	13.7 (±1)	198.6 (±14.5)	15.1 (±1)	218.9 (±14.5)	35	507.5	0.85	0.03	6.5	0.25	7.25	0.28	7.6	0.30	5CR7E0B09NM
C0	011	3.5 (±1)	50.7 (±14.5)	25 (±1.5)	362.5 (±21.7)	27.9 (±1.5)	41.8 (±21.7)	35	507.5	0.85	0.03	6.5	0.25	7.25	0.28	7.6	0.30	5CR7C0011NM
C0	B47	3.8 (±1)	55.1 (±14.5)	15.3 (±0.5)	221.8 (±7.25)	16.8 (±1)	243.6 (±14.5)	35	507.5	0.85	0.03	6.5	0.25	7.25	0.28	7.6	0.30	5CR7C0347NM
E0	086	4 (±1)	58 (±14.5)	16.5 (±0.5)	239.2 (±7.25)	18.2 (±1)	263.9 (±14.5)	35	507.5	0.85	0.03	6.5	0.25	7.25	0.28	7.6	0.30	5CR7E0086NM
C0	118	4 (±0.5)	58 (±7.25)	13 (±1)	188.5 (±14.5)	16.1 (±1)	233.4 (±14.5)	35	507.5	0.85	0.03	6.5	0.25	7.25	0.28	7.6	0.30	5CR7C0118NM
C0	020	4.3 (±1)	62.3 (±14.5)	15.2 (±1)	220.4 (±14.5)	16.6 (±1)	240.7 (±14.5)	35	507.5	0.85	0.03	6.5	0.25	7.25	0.28	7.6	0.30	5CR7C0020NM
C0	028	5 (±1)	72.5 (±14.5)	20 (±1.5)	290 (±21.7)	22 (±2)	319 (±29)	35	507.5	0.85	0.03	6.5	0.25	7.25	0.28	7.6	0.30	5CR7C0028NM
C0	075	5 (±0.5)	72.5 (±7.25)	15 (±1)	217.5 (±14.5)	16.3 (±1.5)	236.3 (±21.7)	35	507.5	0.85	0.03	6.5	0.25	7.25	0.28	7.6	0.30	5CR7C0075NA 5CR7C0075NB
E0	075	5 (±0.5)	72.5 (±7.25)	15 (±1)	217.5 (±14.5)	16.3 (±1.5)	236.3 (±21.7)	35	507.5	0.85	0.03	6.5	0.25	7.25	0.28	7.6	0.30	5CR7E0075NB
C0	001	5.8 (±1)	84.1 (±14.5)	22 (±1.5)	319 (±21.7)	24.2 (±2)	350.9 (±29)	35	507.5	0.85	0.03	6.5	0.25	7.25	0.28	7.6	0.30	5CR7C0001NM
E0	033	5.8 (±0.5)	84.1 (±7.25)	19 (±1)	275.5 (±14.5)	20.8 (±1)	301.6 (±14.5)	35	507.5	0.85	0.03	6.5	0.25	7.25	0.28	7.6	0.30	5CR7E0033NB 5CR7E0033NM
C0	070	5.8 (±1)	84.1 (±14.5)	22.4 (±1.5)	324.8 (±21.7)	24.6 (±1.5)	356.7 (±21.7)	35	507.5	0.85	0.03	6.5	0.25	7.25	0.28	7.6	0.30	5CR7C0070NM
E0	085	6 (±1)	87 (±14.5)	25 (±2)	362.5 (±29)	27.5 (±2)	398.75 (±29)	35	507.5	0.85	0.03	6.5	0.25	7.25	0.28	7.6	0.30	5CR7E0085NM
C0	088	8 (±0.5)	116 (±7.25)	27 (±1)	391.5 (±14.5)	29.5 (±1)	427.75 (±14.5)	35	507.5	0.85	0.03	6.5	0.25	7.25	0.28	7.6	0.30	5CR7C0088NM
C0	036	12 (±1)	174 (±14.5)	25 (±1.5)	362.5 (±21.7)	26.7 (±1.5)	387.15 (±21.7)	35	507.5	0.85	0.03	6.5	0.25	7.25	0.28	7.6	0.30	5CR7C0036NA

⁽¹⁾Codes are referred to the curve with the specific return spring
For different curves, please contact our Sales Department

Control curves without step

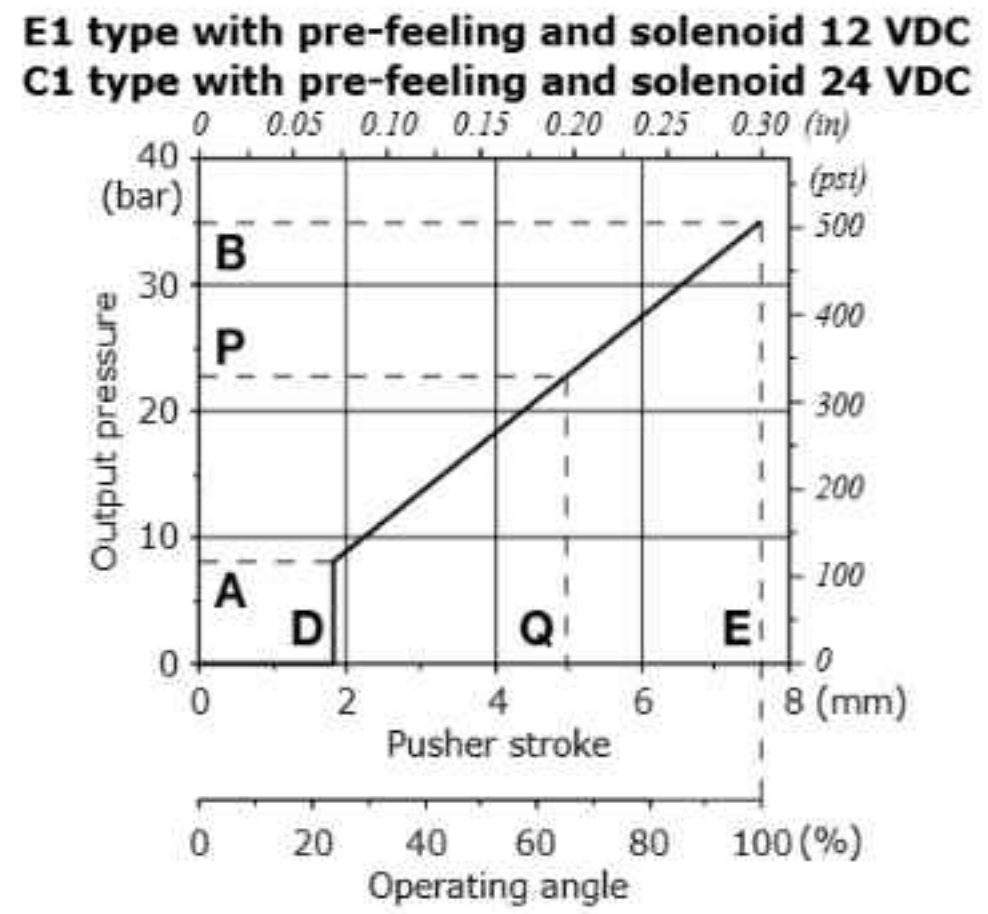
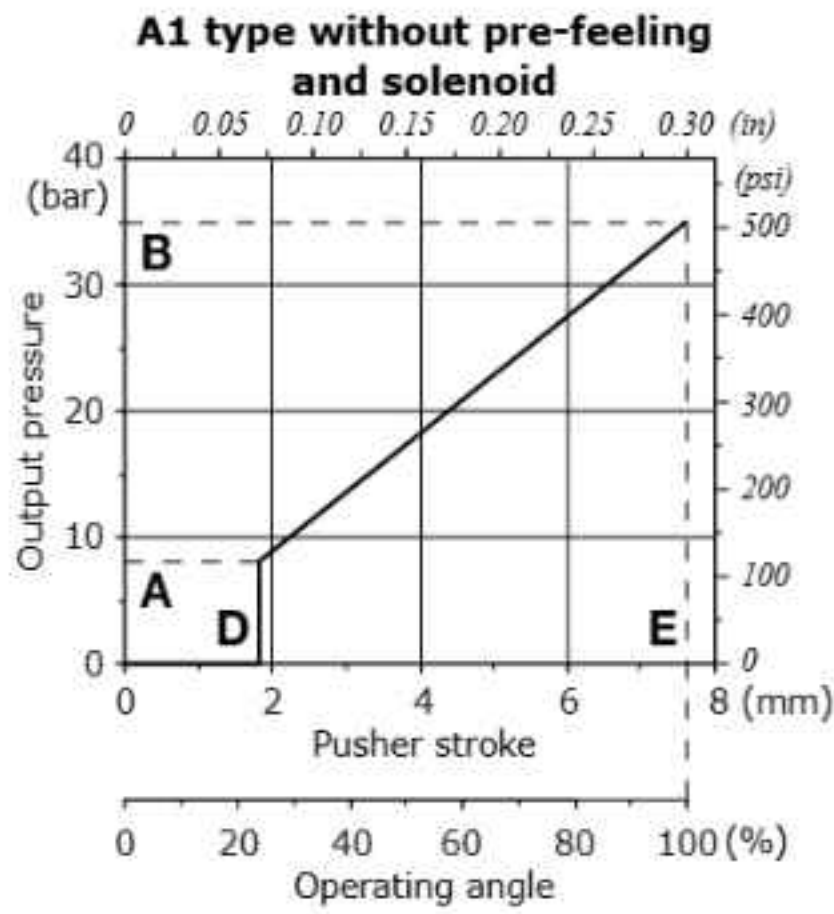

Curve description		Pressure						Stroke						CODE ⁽¹⁾
Type	Nr	A		P		B		D		Q		E		
		bar (\pm toll)	psi (\pm toll)	bar (\pm toll)	psi (\pm toll)	bar (\pm toll)	psi (\pm toll)	mm	in	mm	in	mm	in	
A1	096	4 (\pm 1)	58 (\pm 14.5)			18 (\pm 1)	261 (\pm 14.5)	0.85	0.03			7.6	0.30	5CR7A1096A 5CR7A1096M
With Pre-feeling for electromagnetic detent														
C1	141	4 (\pm 1)	58 (\pm 14.5)	12.8 (\pm 1)	185.6 (\pm 14.5)	18 (\pm 1)	261 (\pm 14.5)	1.55	0.06	5.1	0.2	7.5	0.29	5CR7C1141NM

⁽¹⁾Codes are referred to the curve with the specific return spring
For different curves, please contact our Sales Department



SVM hydraulic joysticks with pedal and other actuations

SVM510-SVM520-SVM521 / SVM500 series / SVM540 series / SVM702-SVM710

- Single and double function
- Damping option
- High sensitivity and low force
- Available with anti-slip rubber coated pedals

Working conditions

This catalogue shows technical specifications and diagrams measured with mineral oil of 46mm²/s - 46 cSt viscosity at 40°C - 104°F temperature.

Nominal flow rating		from 5 to 20 l/min - from 1.32 to 5.28 USgpm
Max. feeding pressure	P on inlet port	from 30 to 100 bar - from 435 to 1450 psi
Max. backpressure	T on outlet port	3 bar - 43.5 psi
Max. hysteresis		0.5 bar - 7.25 psi
Internal leakage (all ports)	at 30 bar - 435 psi, P⇒T	from 2.5 to 4.5 cm ³ /min - from 0.15 to 0.27 in ³ /min
Fluid		mineral oil
Fluid temperature	with NBR (BUNA-N) seals	from -10°C to 80°C - from 14 °F to 176 °F
	operating range	from 15 to 75 mm ² /s - from 15 to 75 cSt
Viscosity	min.	12 mm ² /s - 12 cSt
	max.	400 mm ² /s - 400 cSt
Max. contamination level		-/15/12 - ISO 4406 - NAS1638 class 6
Ambient temperature	without electric devices	from -40°C to 60°C - from 40 °F to 140 °F
	with electric devices	from -20°C to 50°C - from -4 °F to 122 °F

NOTE - for different conditions please contact Sales Dpt

REFERENCE STANDARD

	BSP	UN-UNF
THREAD ACCORDING TO	ISO 228/1	ISO 263
	BS 2779	ANSI B1.1 unified
CAVITY DIMENSION ACCORDING TO	ISO 1179	11926
	SAE	J11926
	DIN 3852-2 shape X or Y	

PORTS THREADING

PORTS	Threads		Fitting tightening torque	
	UNI EN ISO 1179	UNI EN ISO 11926-2	Nm	lbf ^t
P inlet	G 1/4	7/16-20 (SAE 4)	30	22.13
Ports	G 1/4	7/16-20 (SAE 4)	30	22.13
T outlet	G 1/4	7/16-20 (SAE 4)	30	22.13

NOTE - These torques are recommended. Assembly tightening torque depends on many factors, including lubrication, coating and surface finishing. The manufacturer has to be consulted.

Dimensions and hydraulic circuit

SVM510 type

Hydraulic circuit

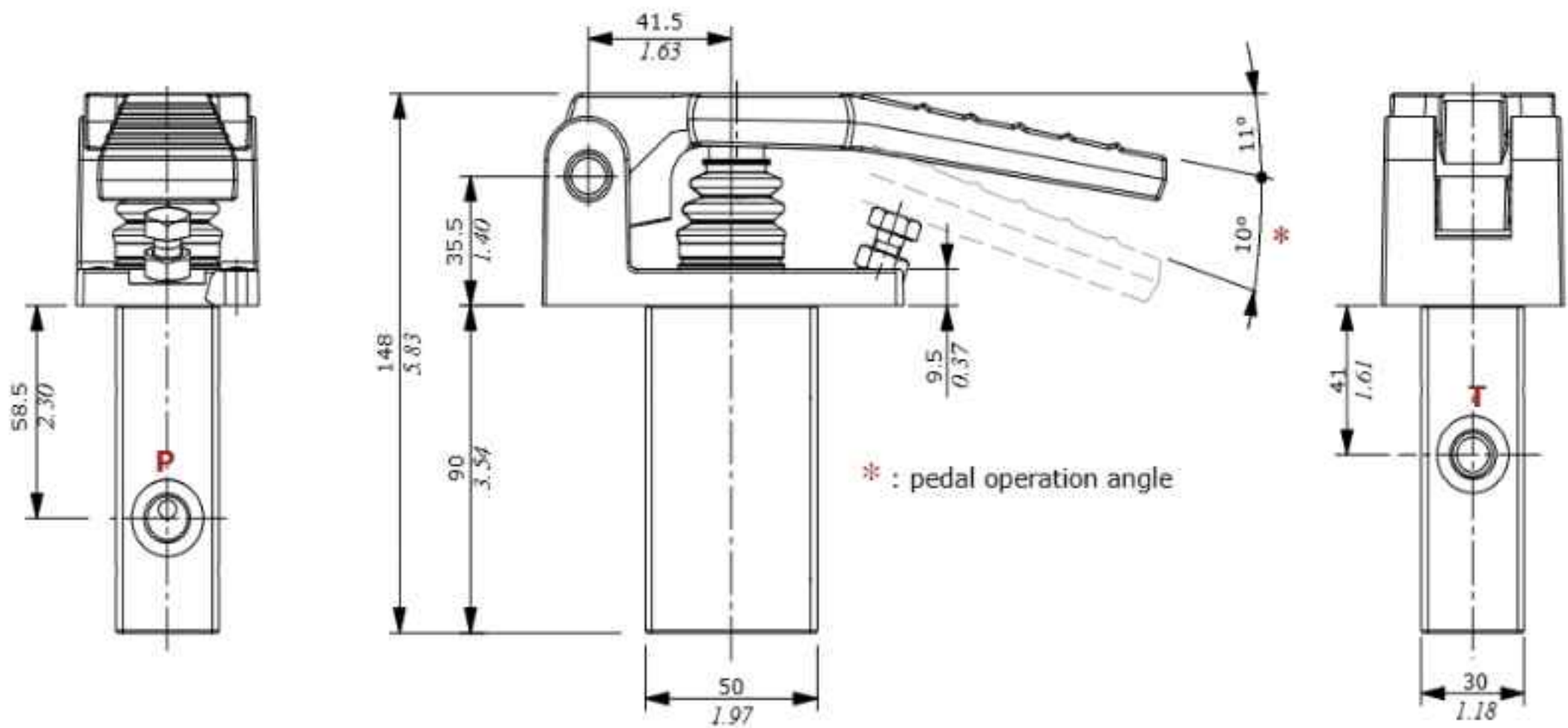
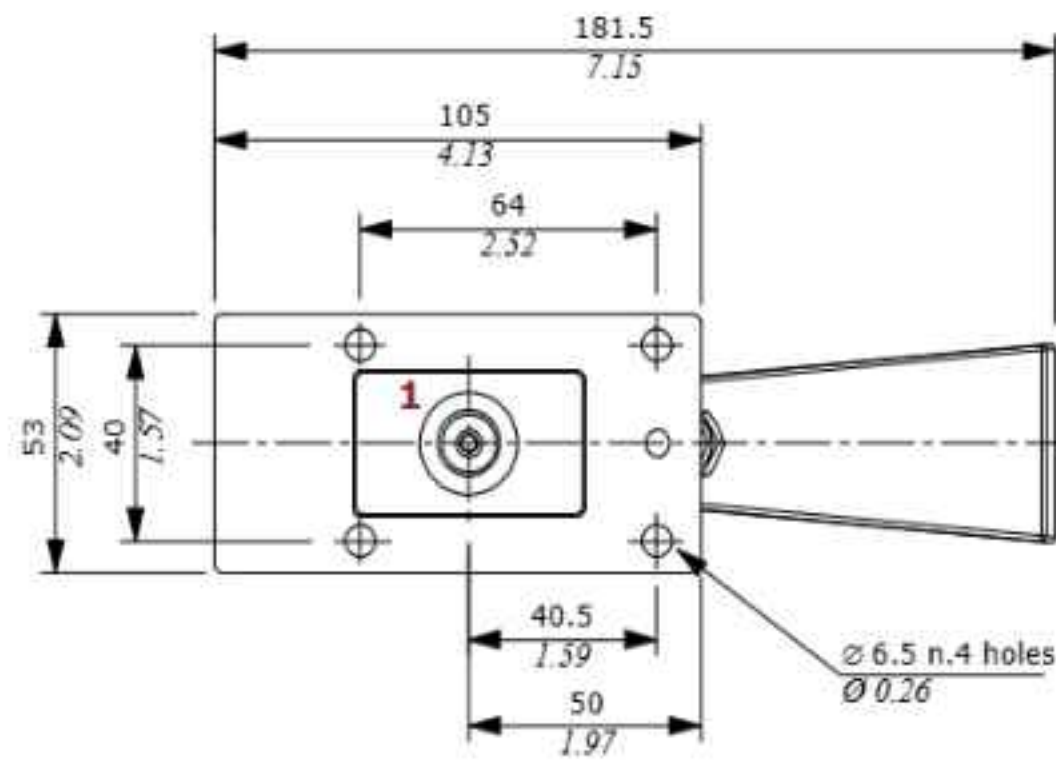
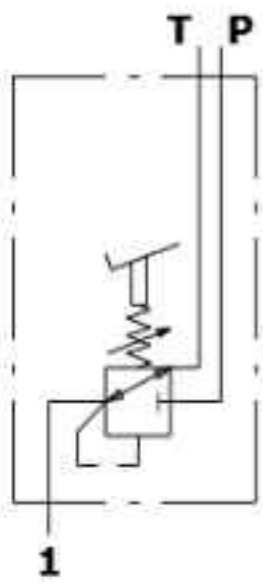

Dimensions and hydraulic circuit

SVM520 type

Configuration with side P and T ports.

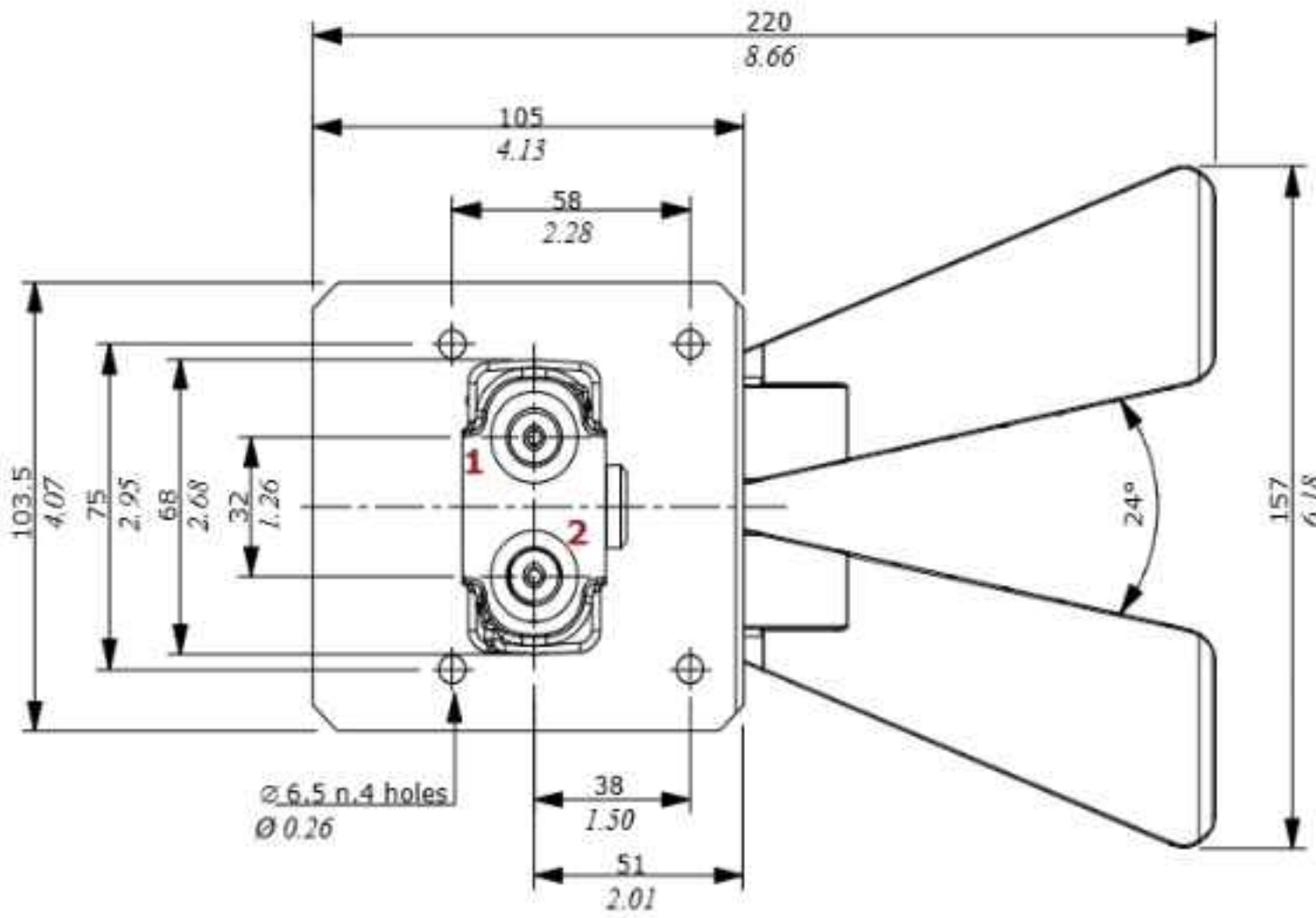

Hydraulic circuit

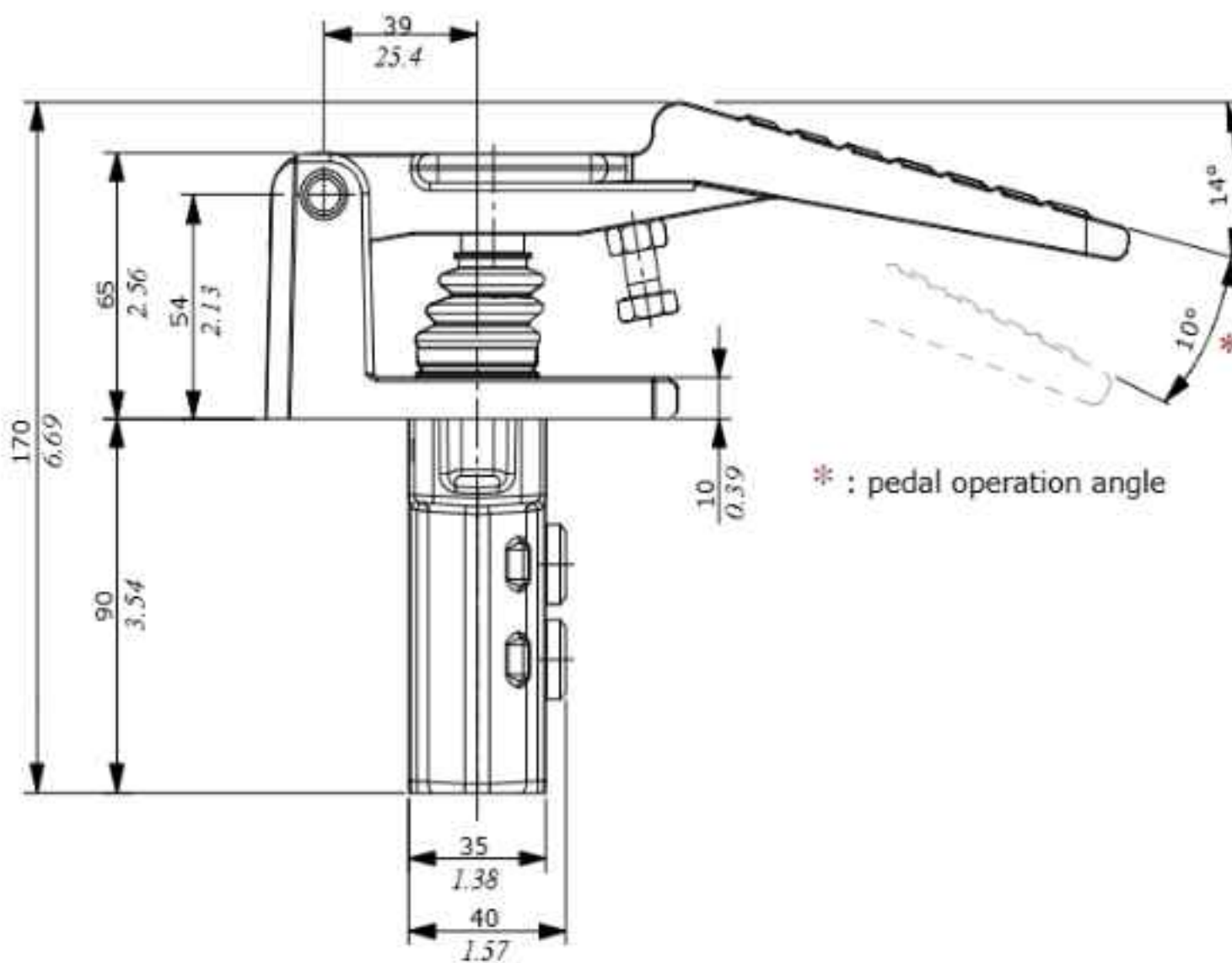
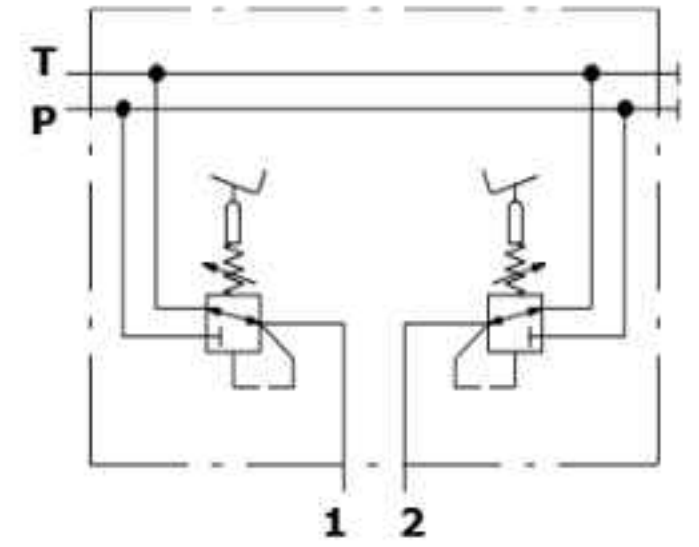

* : pedal operation angle

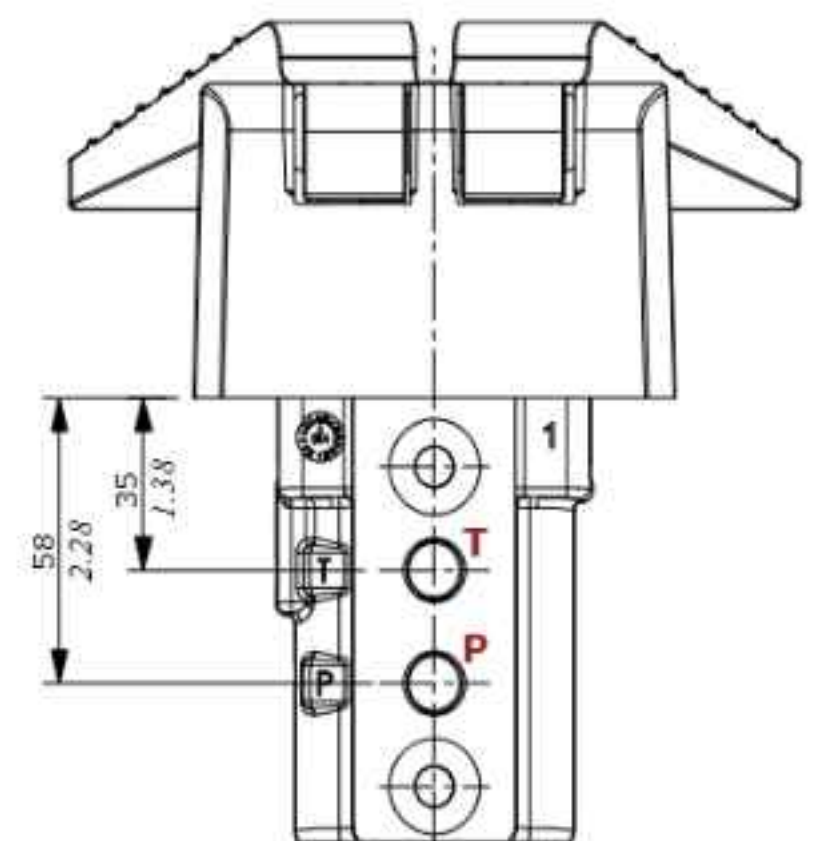

Dimensions and hydraulic circuit

SVM521 type

Configuration with bottom P and T ports.

Hydraulic circuit

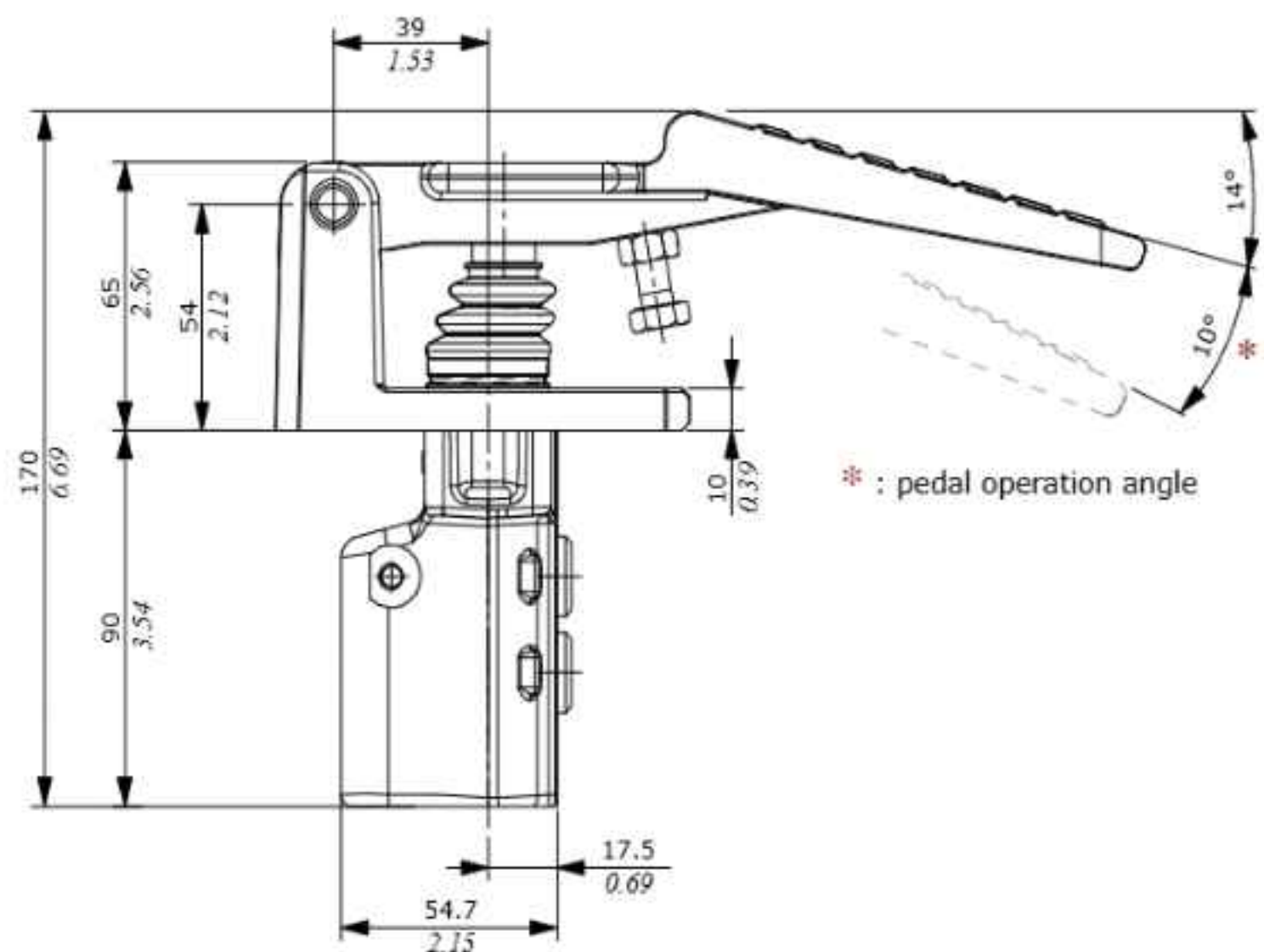
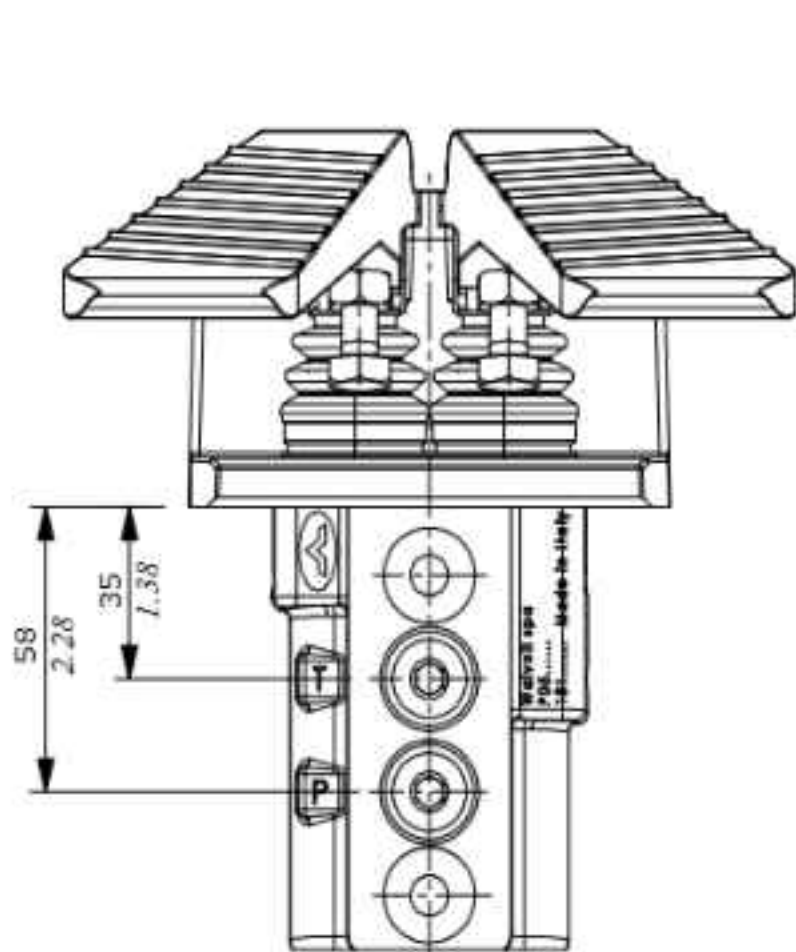
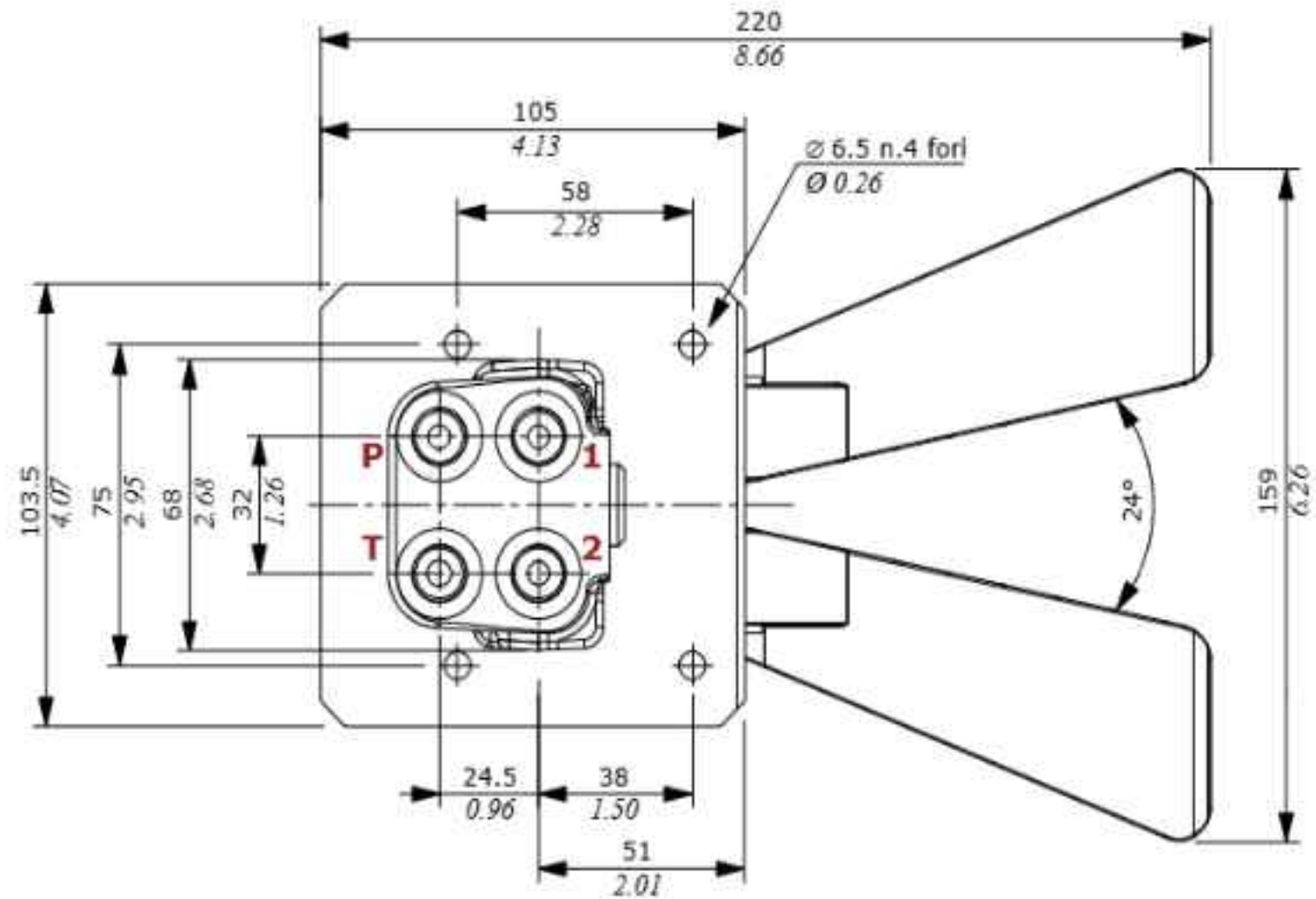
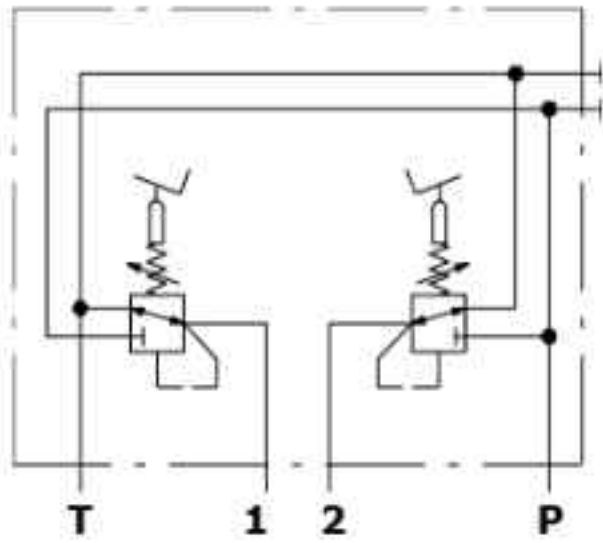

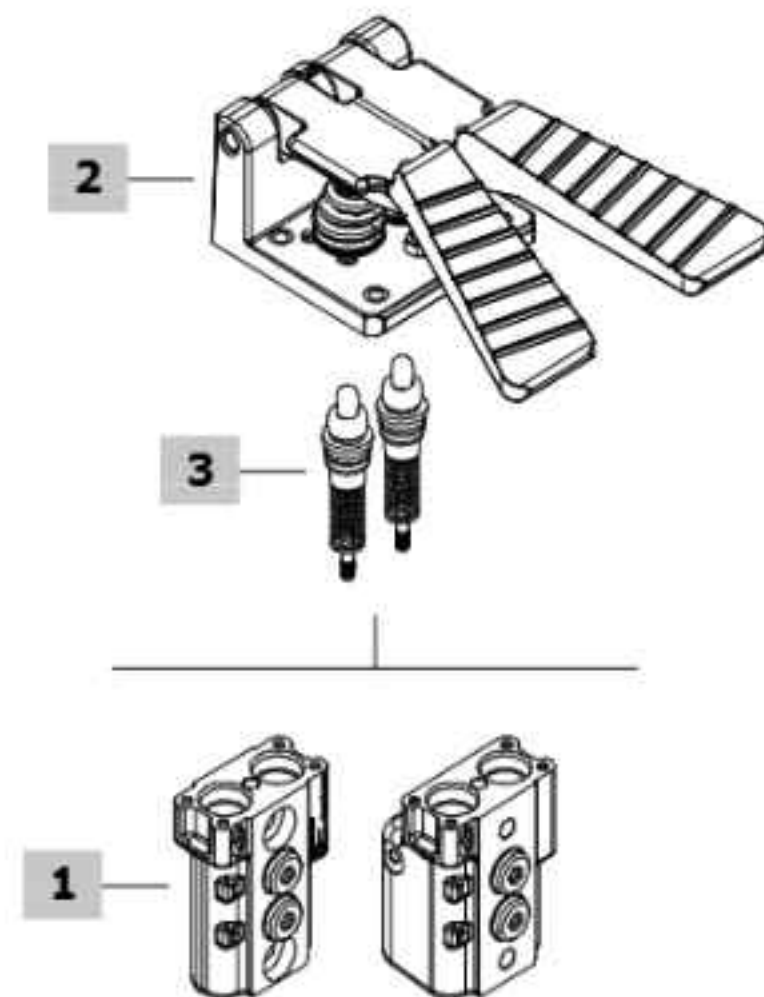
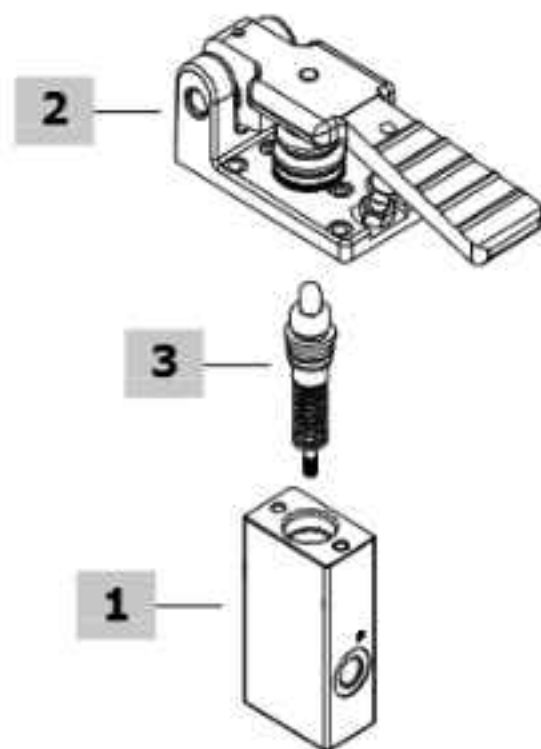
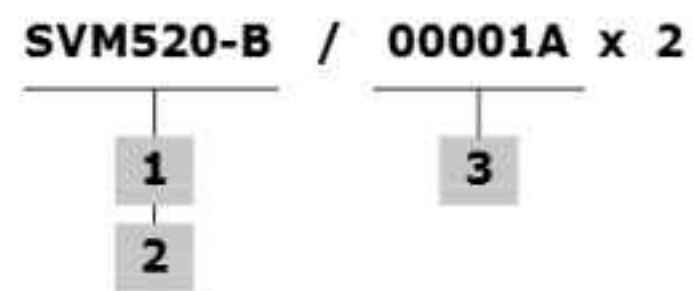
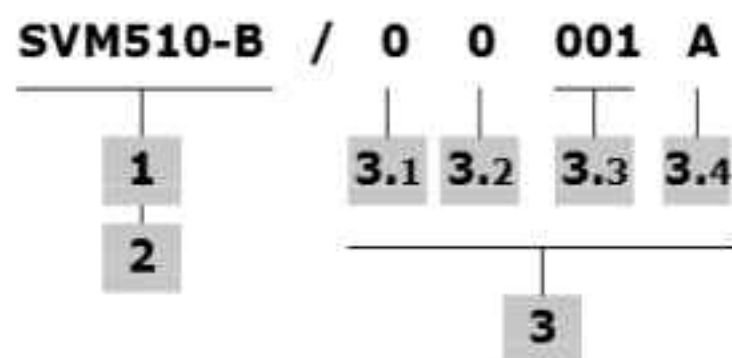

1 Body kit *

TYPE	CODE	DESCRIPTION
SVM510-B	3C03710300	Single pedal configuration
SVM520-B	3C03122300	Double pedal configuration with side P and T ports
SVM521-B	3C03122310	Double pedal configuration with bottom P and T ports

2 Operating pedal

TYPE	CODE	DESCRIPTION
SVM510	5CIN5003	Single pedal operating kit
SVM520-521	5CIN5002	Double pedal operating kit

3 Pressure control curves

For configuration and list available see from page 82

3.1 Curve type

TYPE	DESCRIPTION
0	Standard

3.2 Typology of curves

TYPE	DESCRIPTION
0	With step
1	Without step

3.3 Curve identification

Progressive number,

3.4 Return springs

TYPE	DESCRIPTION
A	Operation range from 23 to 35.2 N - from 5.17 to 7.91 lbf
B	Operation range from 23 to 68.1 N - from 5.17 to 15.31 lbf
C	Operation range from 89 to 176 N - from 20 to 39.56 lbf
D	Operation range from 110 to 220 N - from 24.73 to 49.46 lbf
E	Operation range from 138 to 276 N - from 31 to 62.04 lbf

NOTE (*) - Codes are referred to **BSP** thread.

Dimensions and hydraulic circuit

SVM500 type

Configuration with lower ports.

Hydraulic circuit

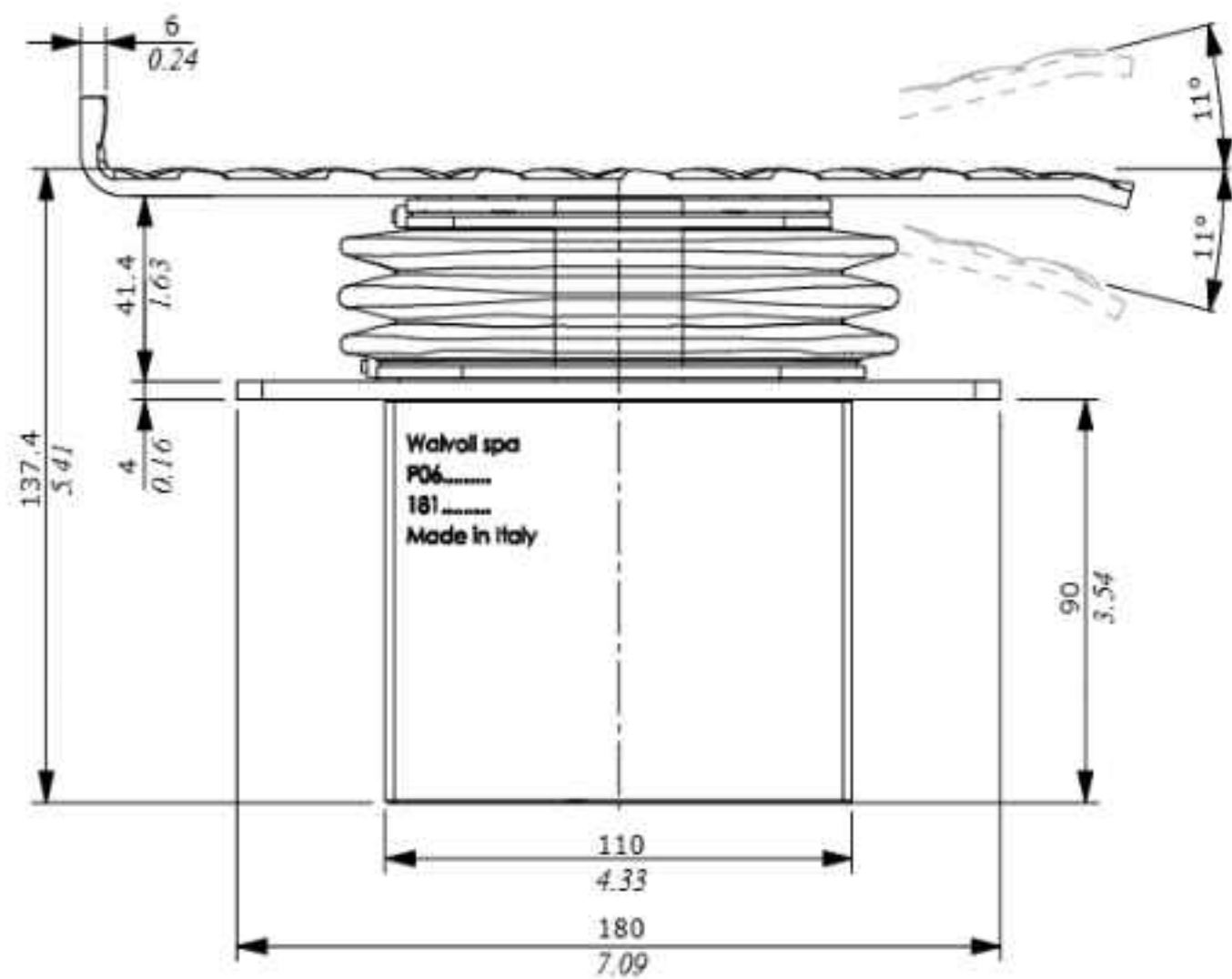
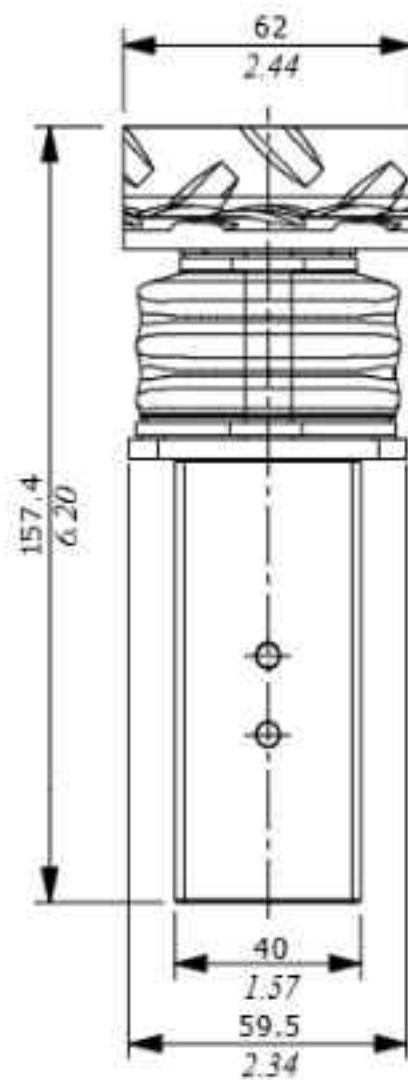
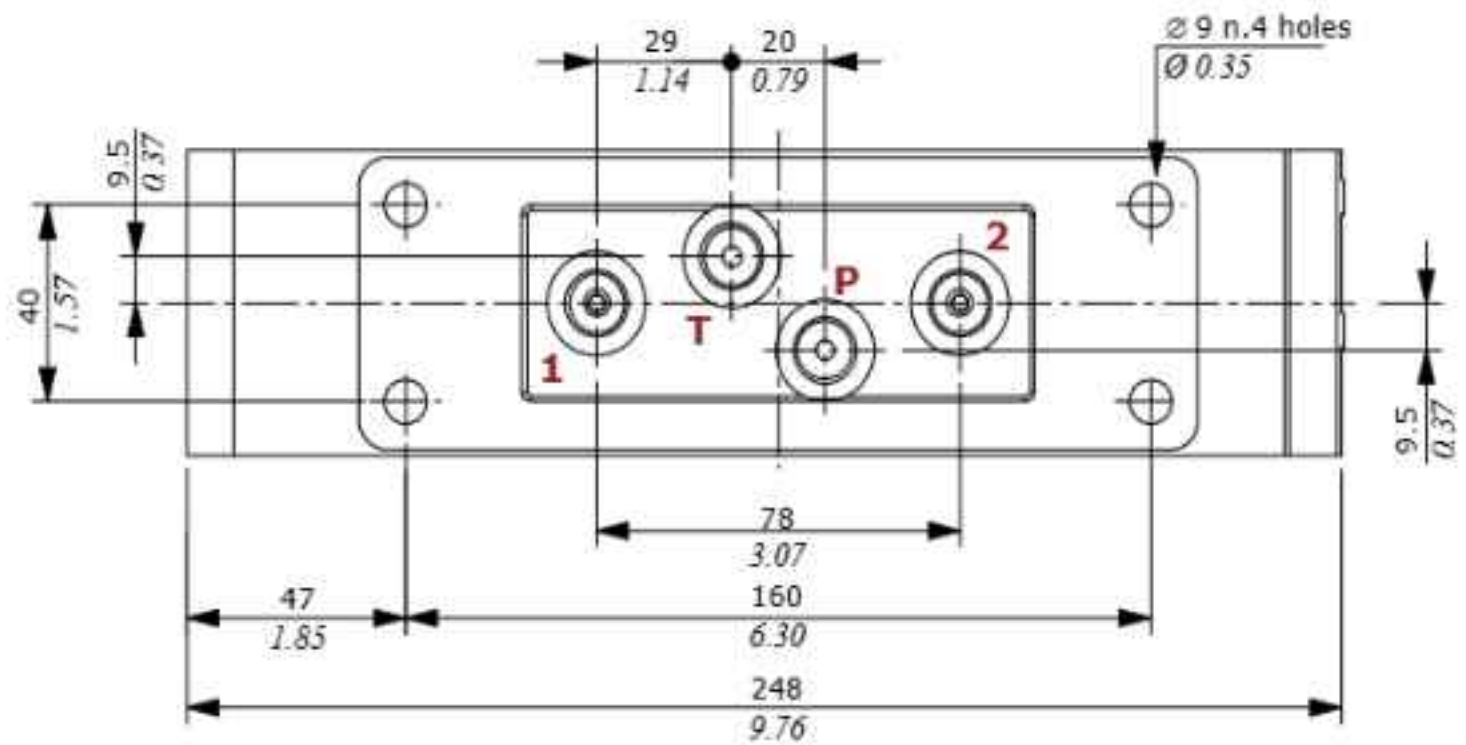
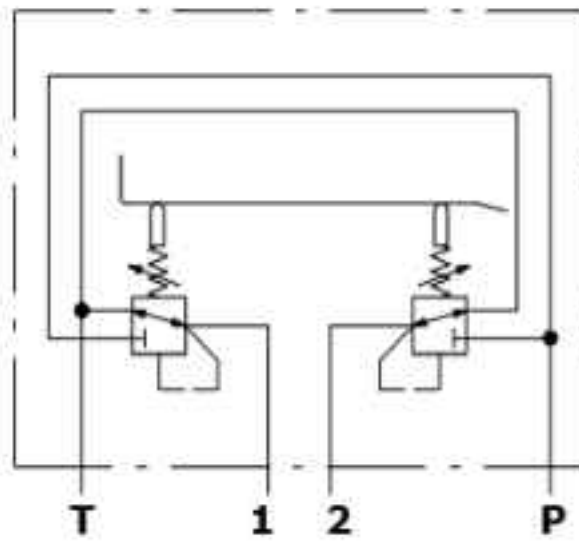

Dimensions and hydraulic circuit

SVM502 type

Configuration with side P and T ports, lower 1 and 2 ports.

Hydraulic circuit

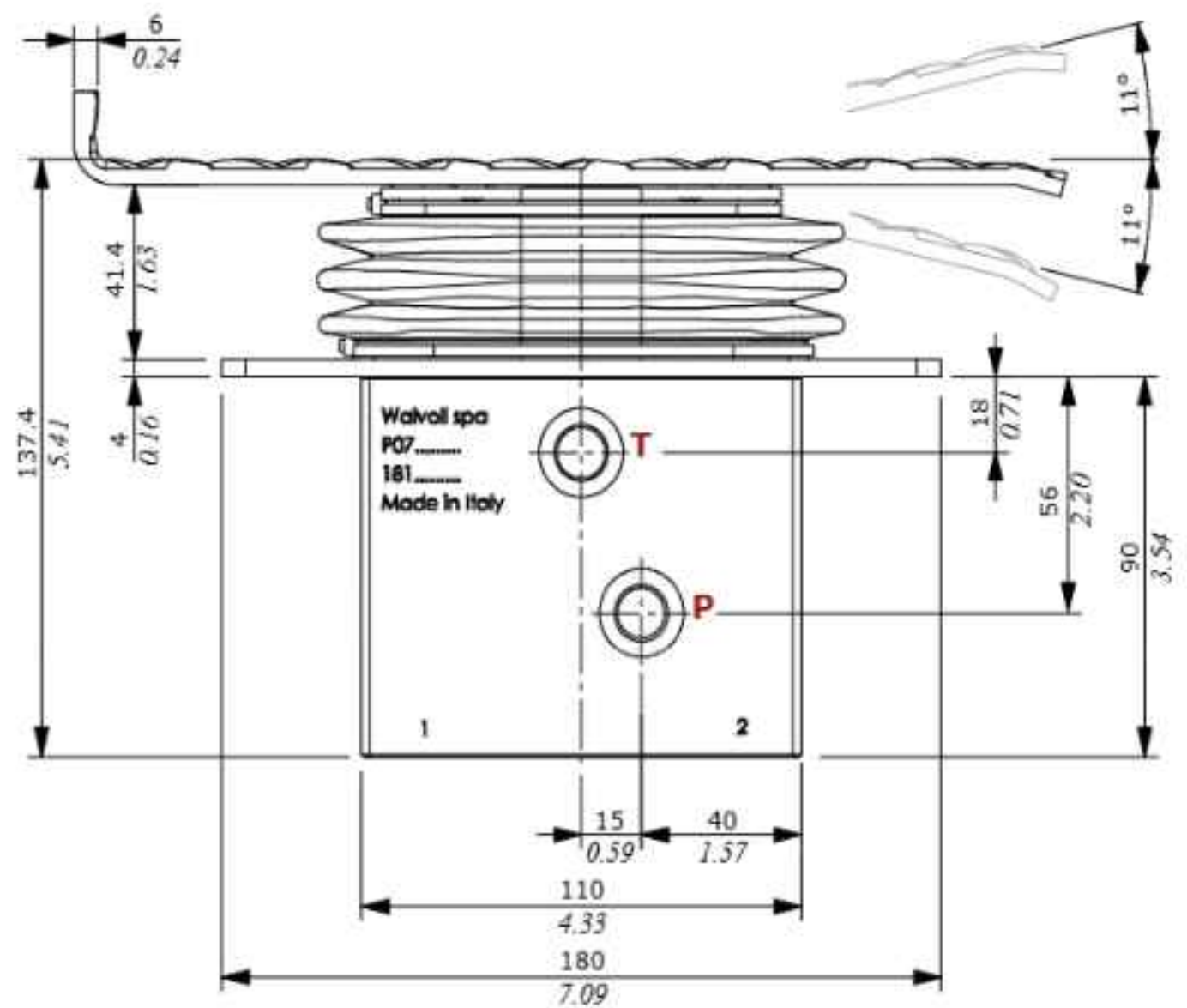
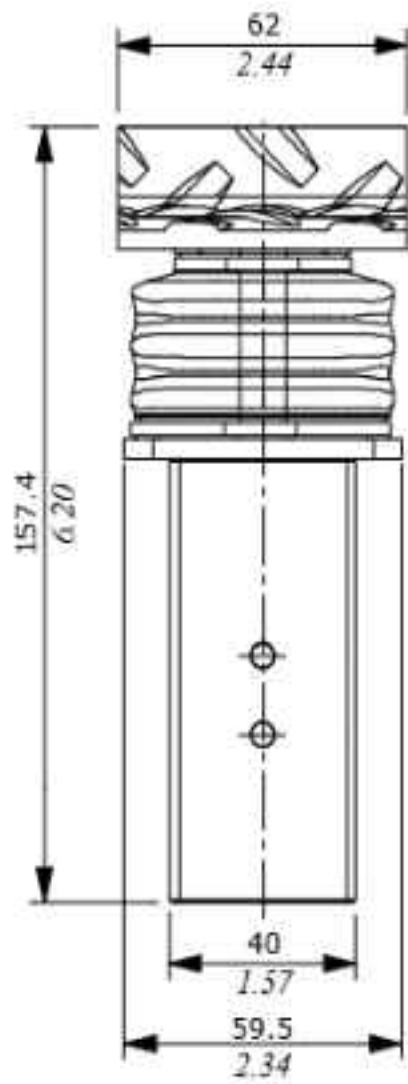
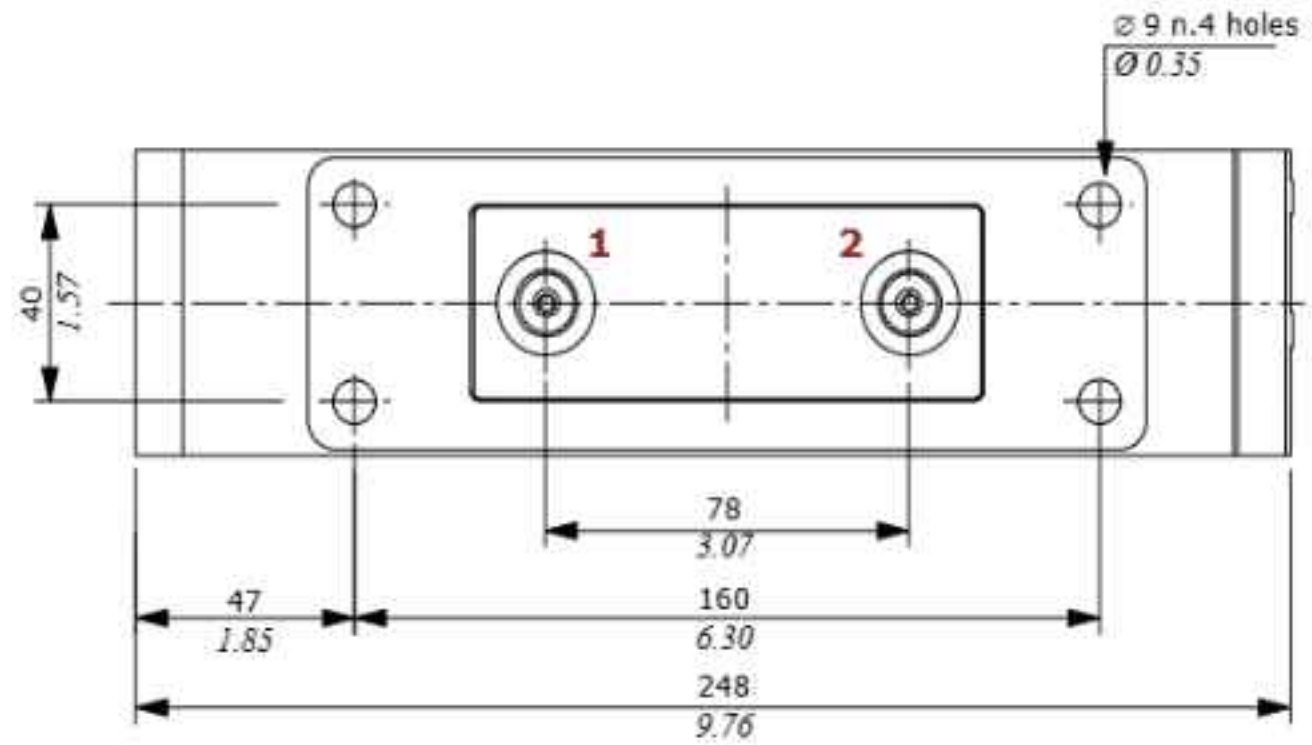
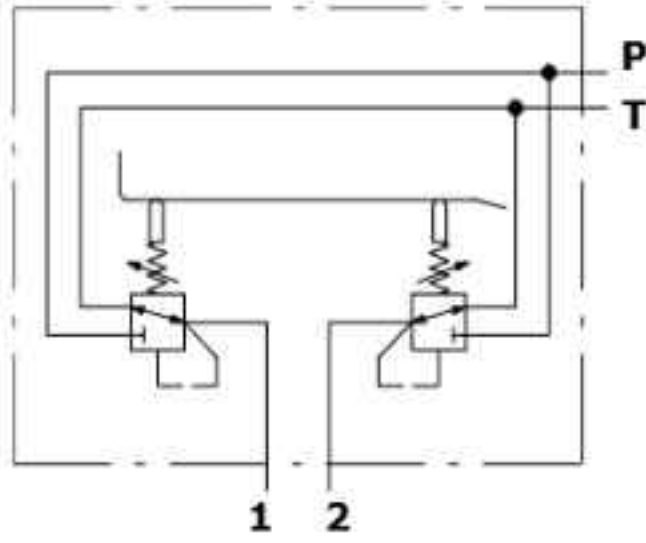

Ordering codes

SVM500-B / 01 F - 0 0 001 A x 2

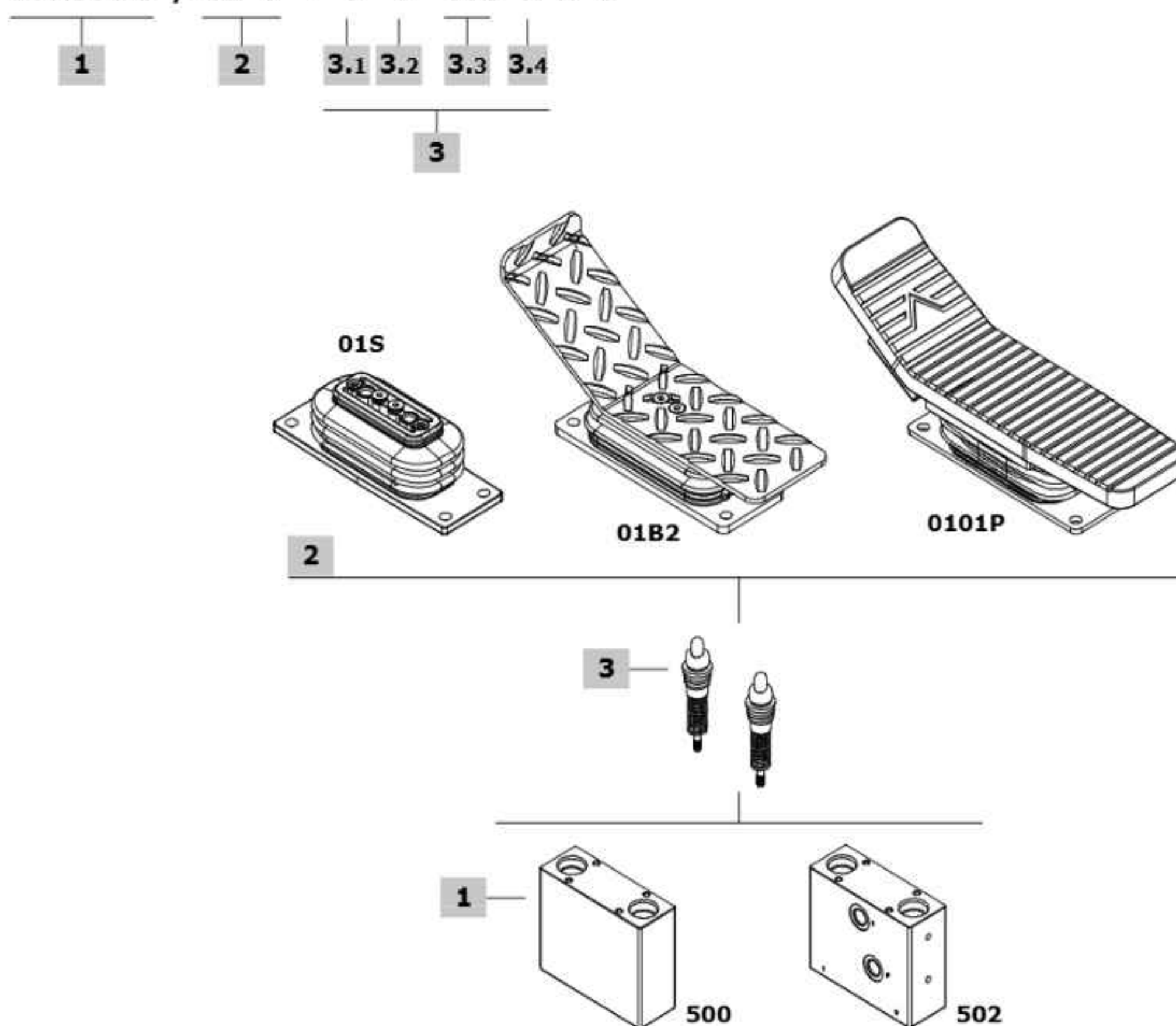

1 Body kit *

TYPE	CODE	DESCRIPTION
SVM500-B	3CO3510300	Configuration with lower ports
SVM502-B	3CO3510320	Configuration with side P and T ports, lower 1 and 2 ports

2 Control options

TYPE	CODE	DESCRIPTION
01S	5CIN5001S	With spring return in neutral position and rubber bellow, without pedal
01F	5CIN5001F	As 01S flat pedal
01B1	5CIN5001B1	As 01S 154° bent pedal
01B2	5CIN5001B2	As 01S 150° bent pedal
0101P	5CIN50001P00	As type 01S with 150° bent pedal and anti-slip rubber coating
0102P	5CIN50002P00	As type 01S with 150° bent and 30° tilted pedal, short type; anti-slip rubber coating
0103P	5CIN50003P00	As type 01S with 150° bent and 30° tilted pedal, long type; anti-slip rubber coating

3 Pressure control curves

For configuration and list available see from page 82

3.1 Curve type

TYPE	DESCRIPTION
0	Standard

3.2 Typology of curves

TYPE	DESCRIPTION
0	With step
1	Without step

3.3 Curve identification

Progressive number

3.4 Return springs

TYPE	DESCRIPTION
A	Operation range from 23 to 35.2 N - from 5.17 to 7.91 lbf
B	Operation range from 23 to 68.1 N - from 5.17 to 15.31 lbf
C	Operation range from 89 to 176 N - from 20 to 39.56 lbf
D	Operation range from 110 to 220 N - from 24.73 to 49.46 lbf
E	Operation range from 138 to 276 N - from 31 to 62.04 lbf

NOTE (*) - Codes are referred to **BSP** thread.

01S type

With spring return in neutral position, without pedal.

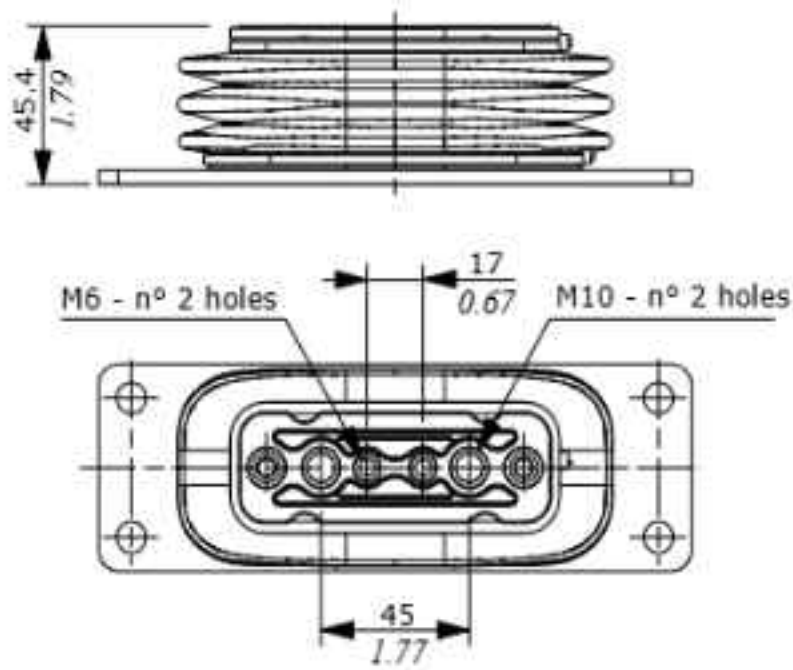

01F type

With spring return in neutral position.
Flat pedal with corrugated sheet, white galvanized.

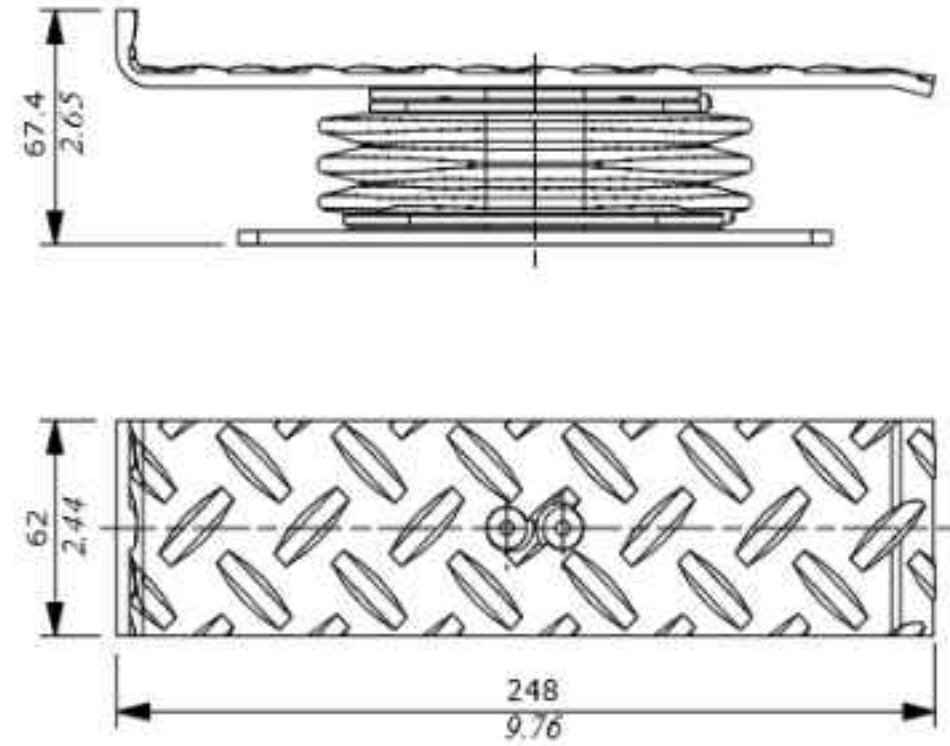

01B1 type

With spring return in neutral position.
Shaped pedal with corrugated sheet, white galvanized.

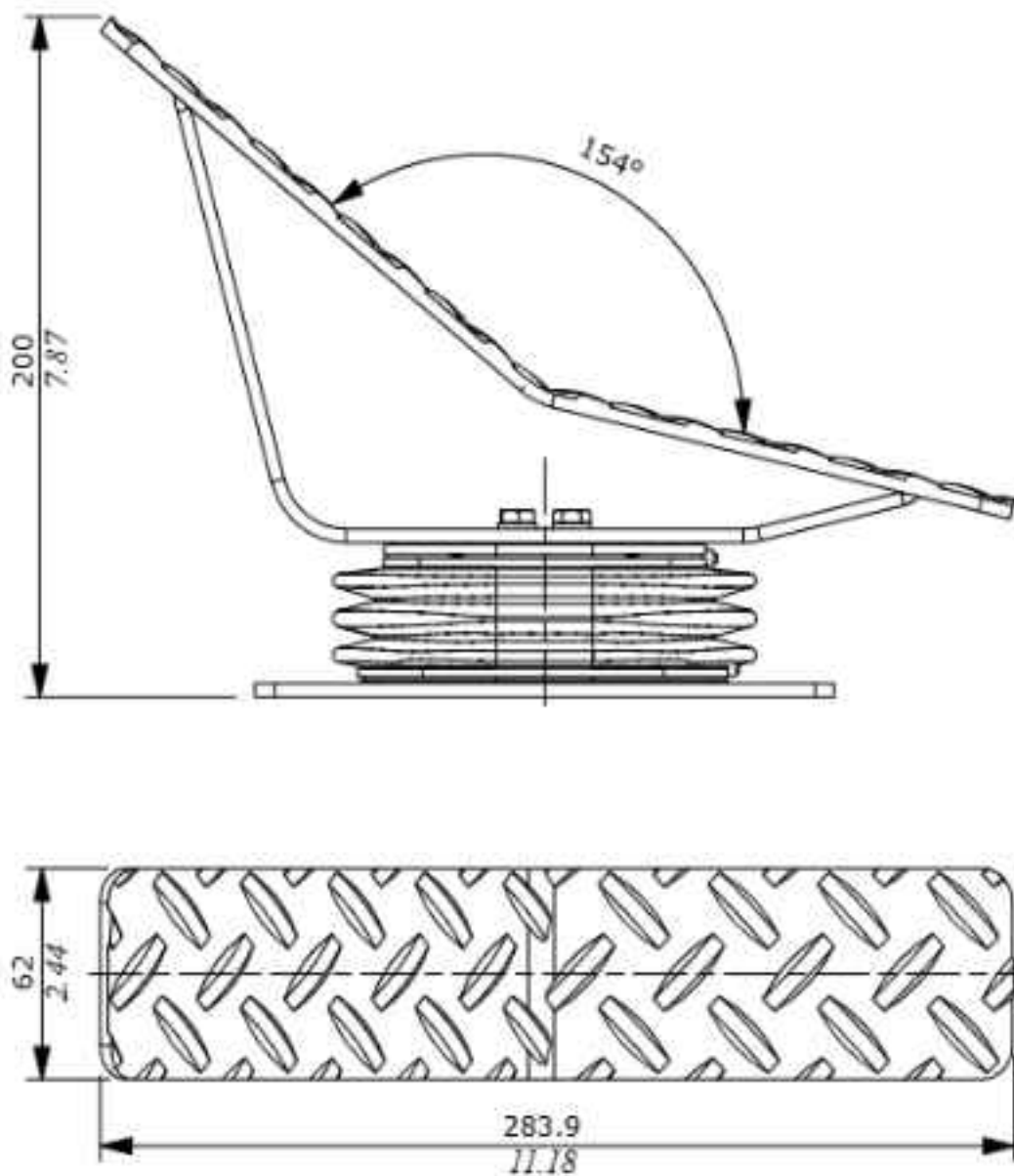

01B2 type

With spring return in neutral position.
Sloped pedal with corrugated sheet, white galvanized.

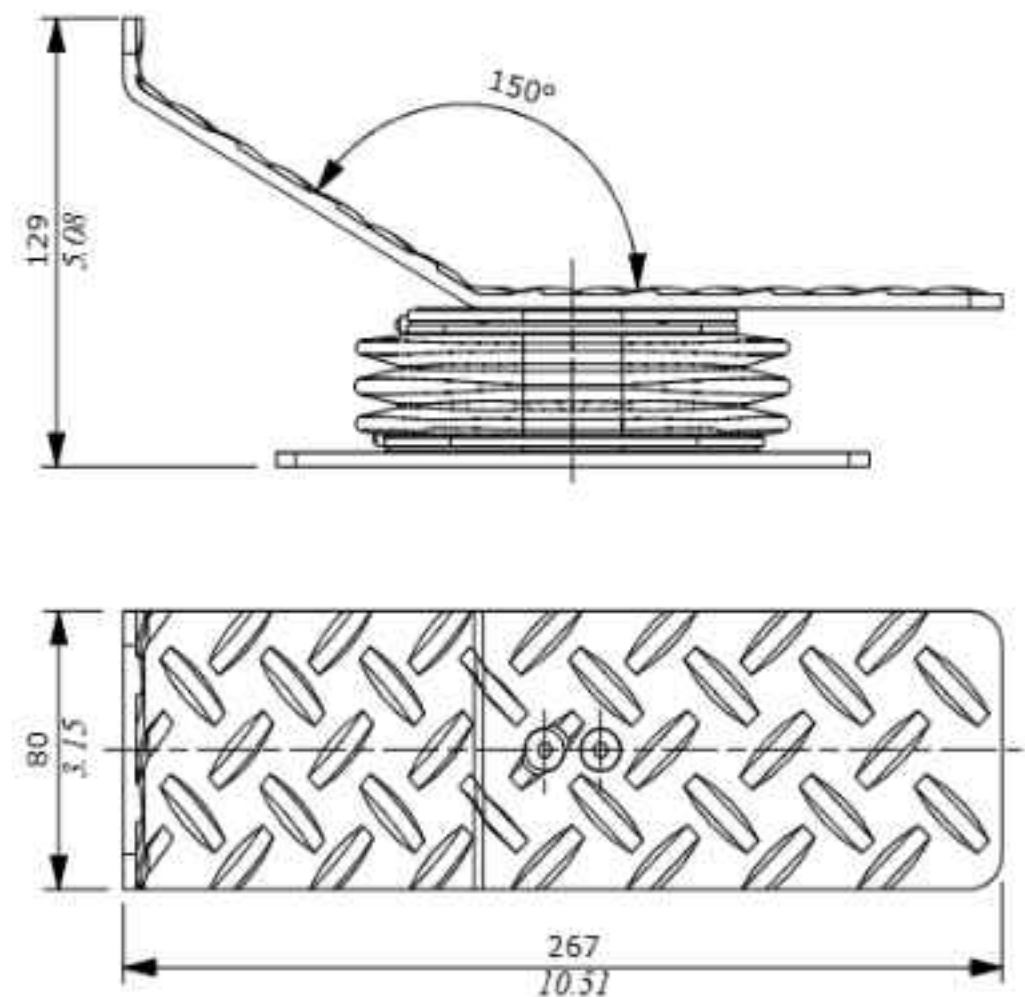

Control options

0101P type

With spring return in neutral position.
Bent pedal with anti-slip rubber coating.

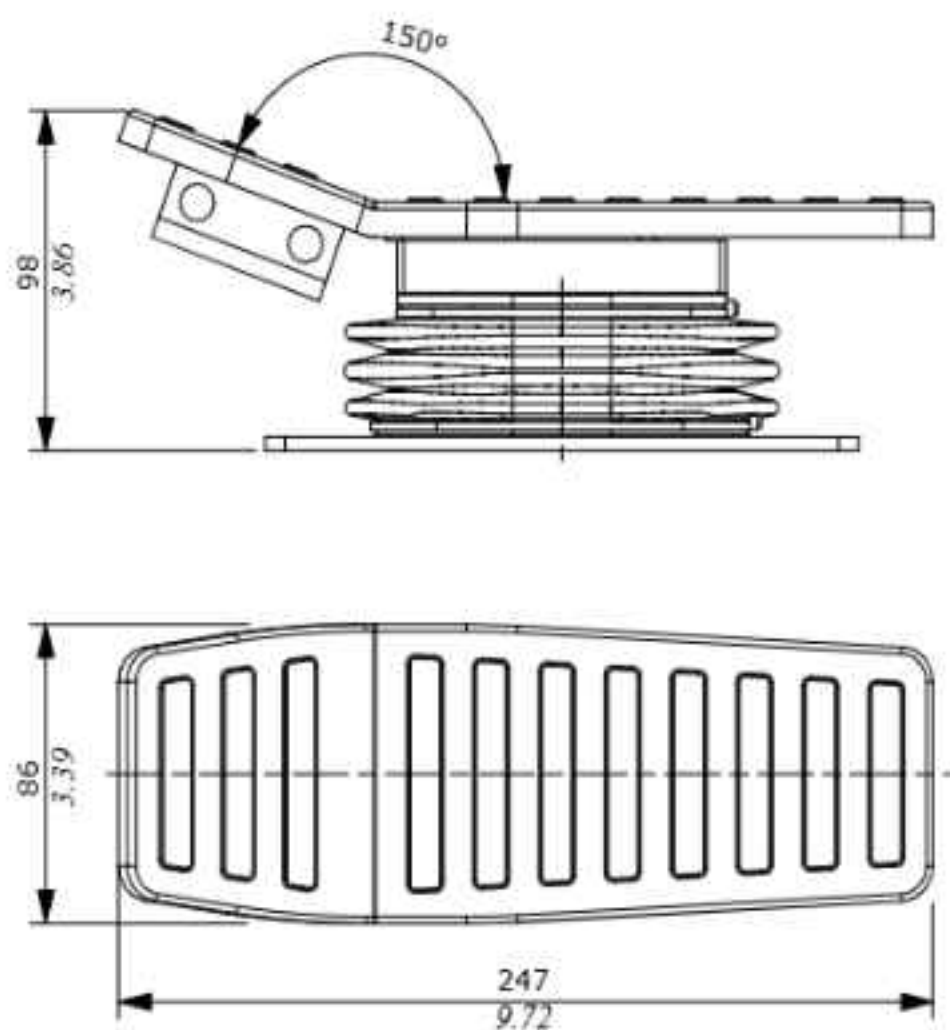

0102P type

With spring return in neutral position.
Bent and tilted pedal with anti-slip rubber coating, short model.

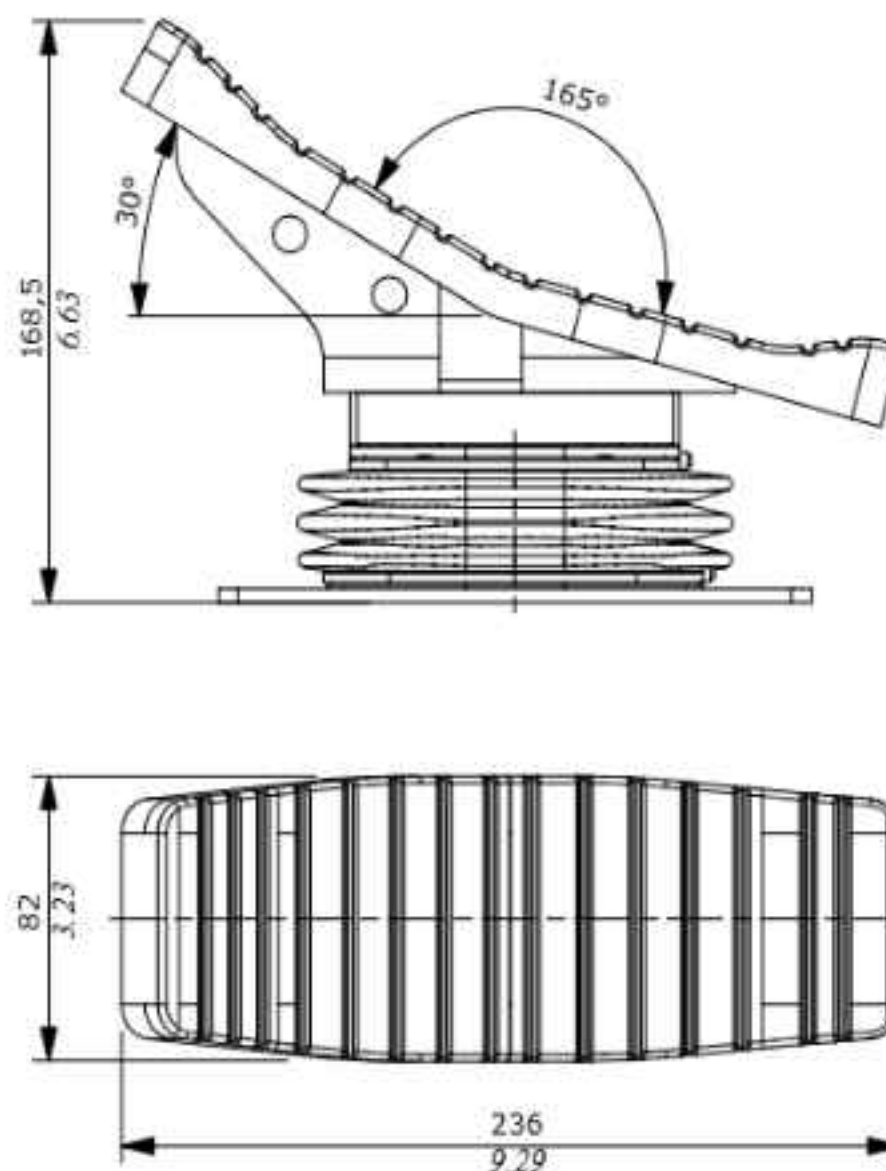

0103P type

With spring return in neutral position.
Bent and tilted pedal with anti-slip rubber coating, long model.

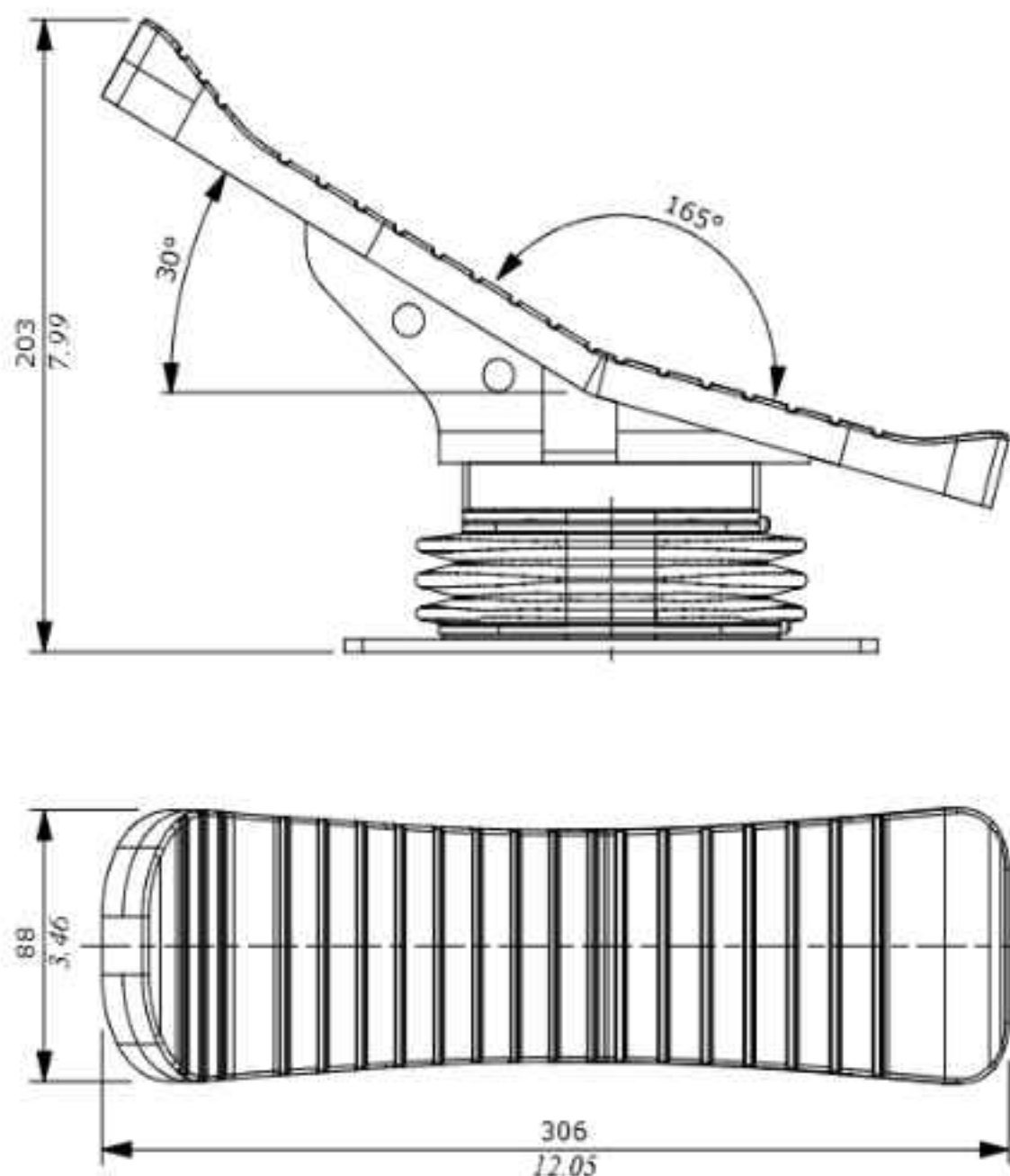

Dimensions and hydraulic circuit

SVM540 type

Double pedal configuration provided of damping system for swing reduction.

Hydraulic circuit

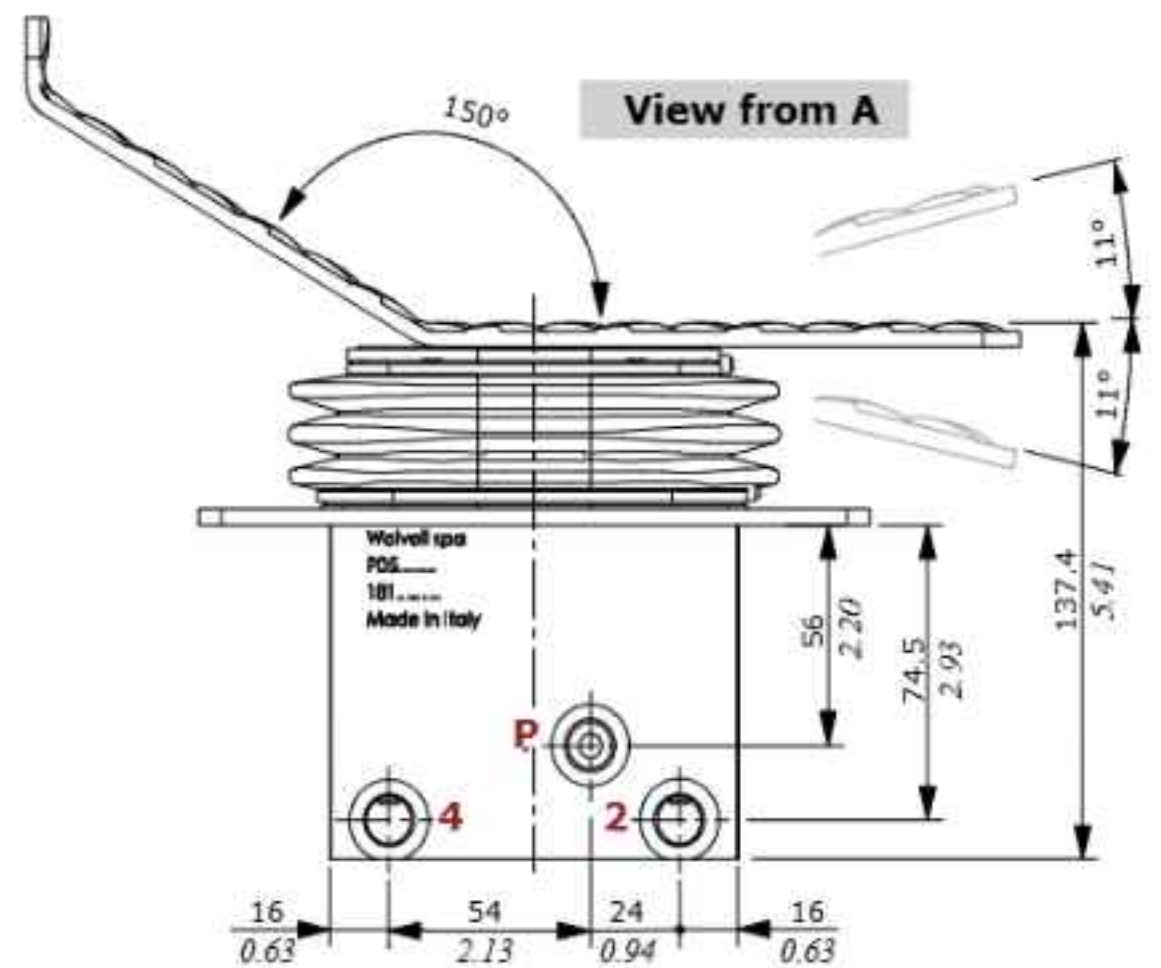
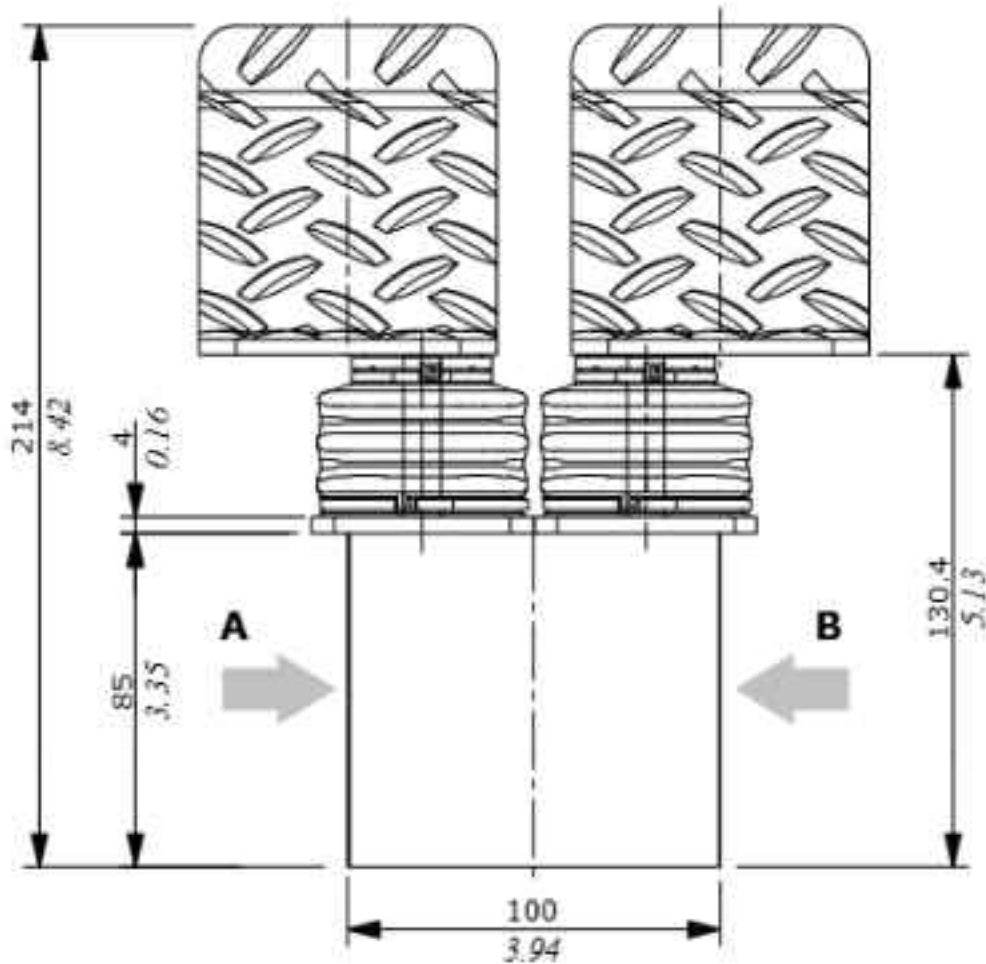
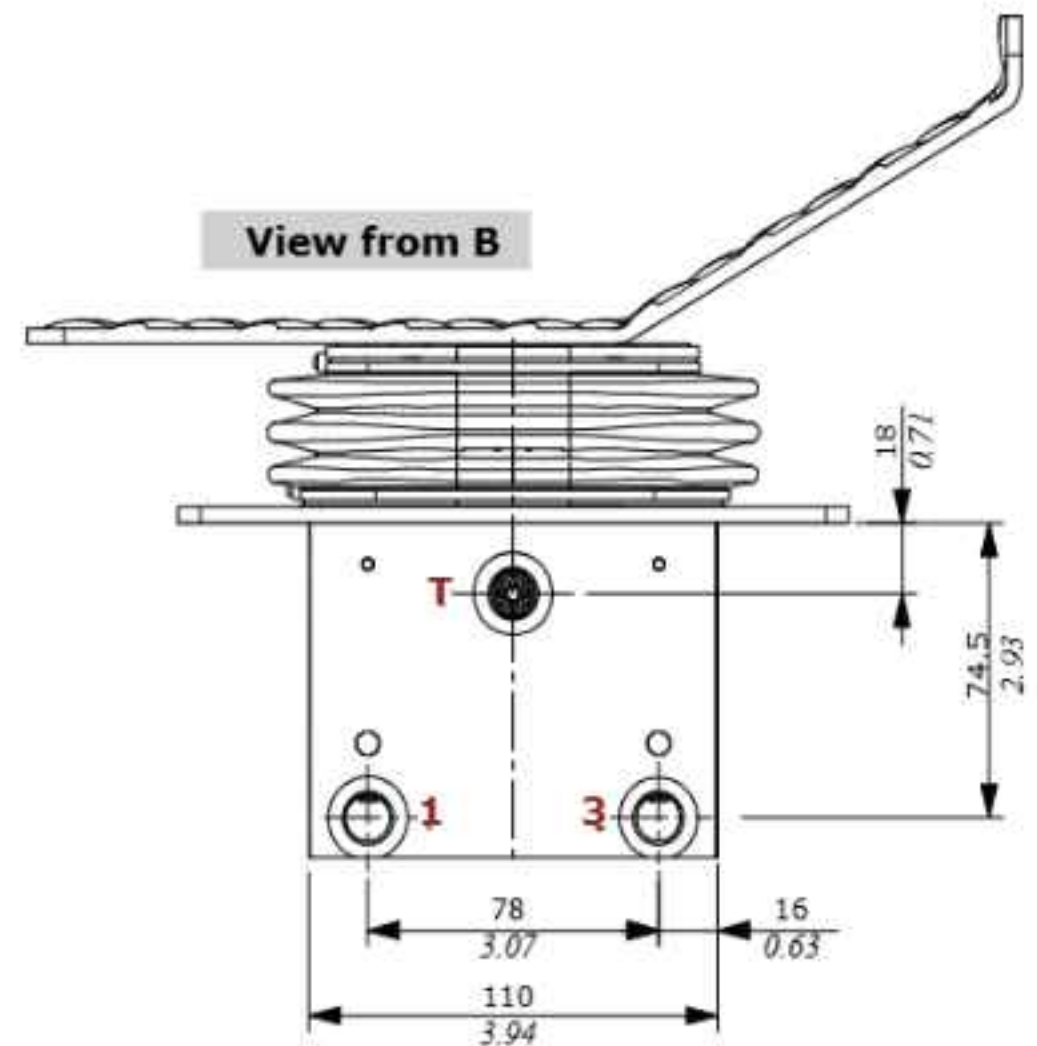
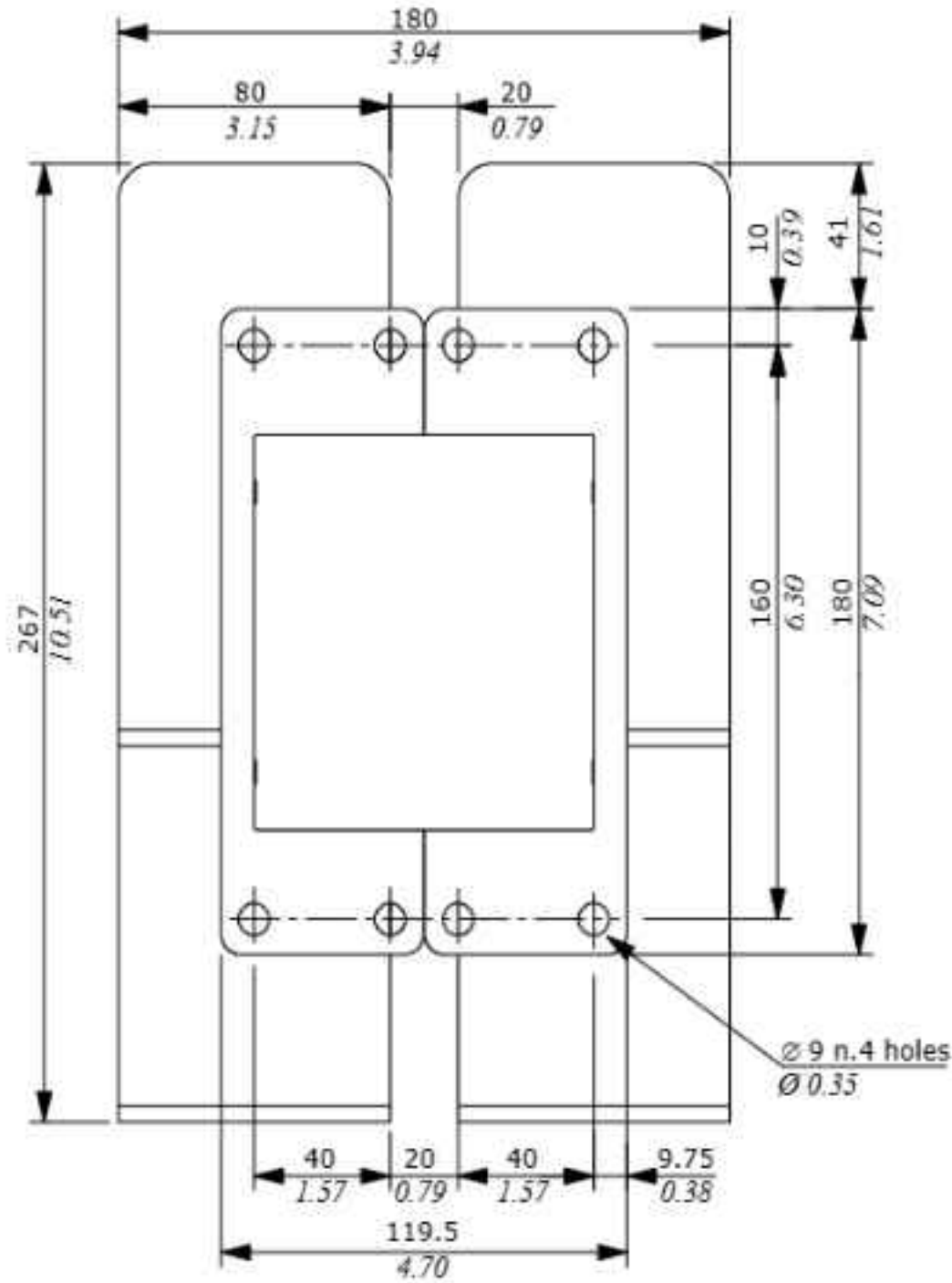
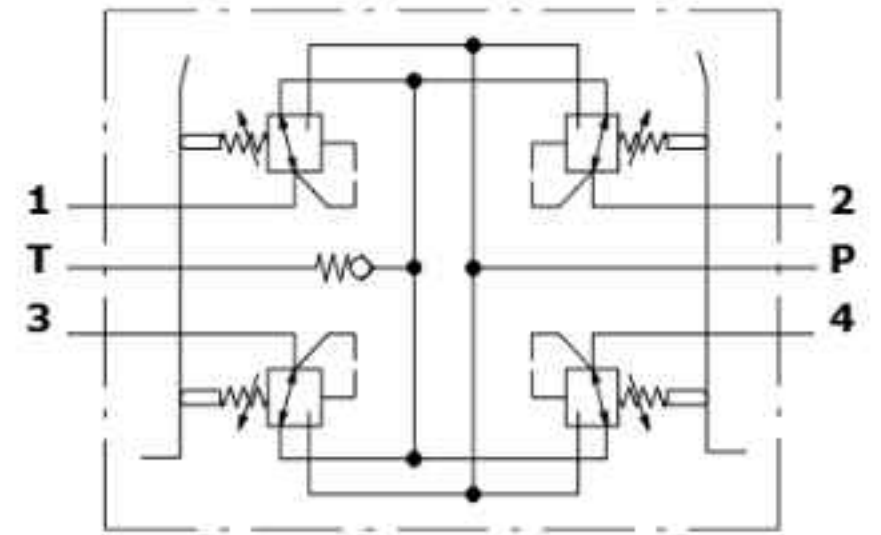

Dimensions and hydraulic circuit

SVM546 version

Double pedal configuration provided of damping system for swing reduction, with shuttle valves and auxiliary port. Dimensions are the same as SVM540 version.

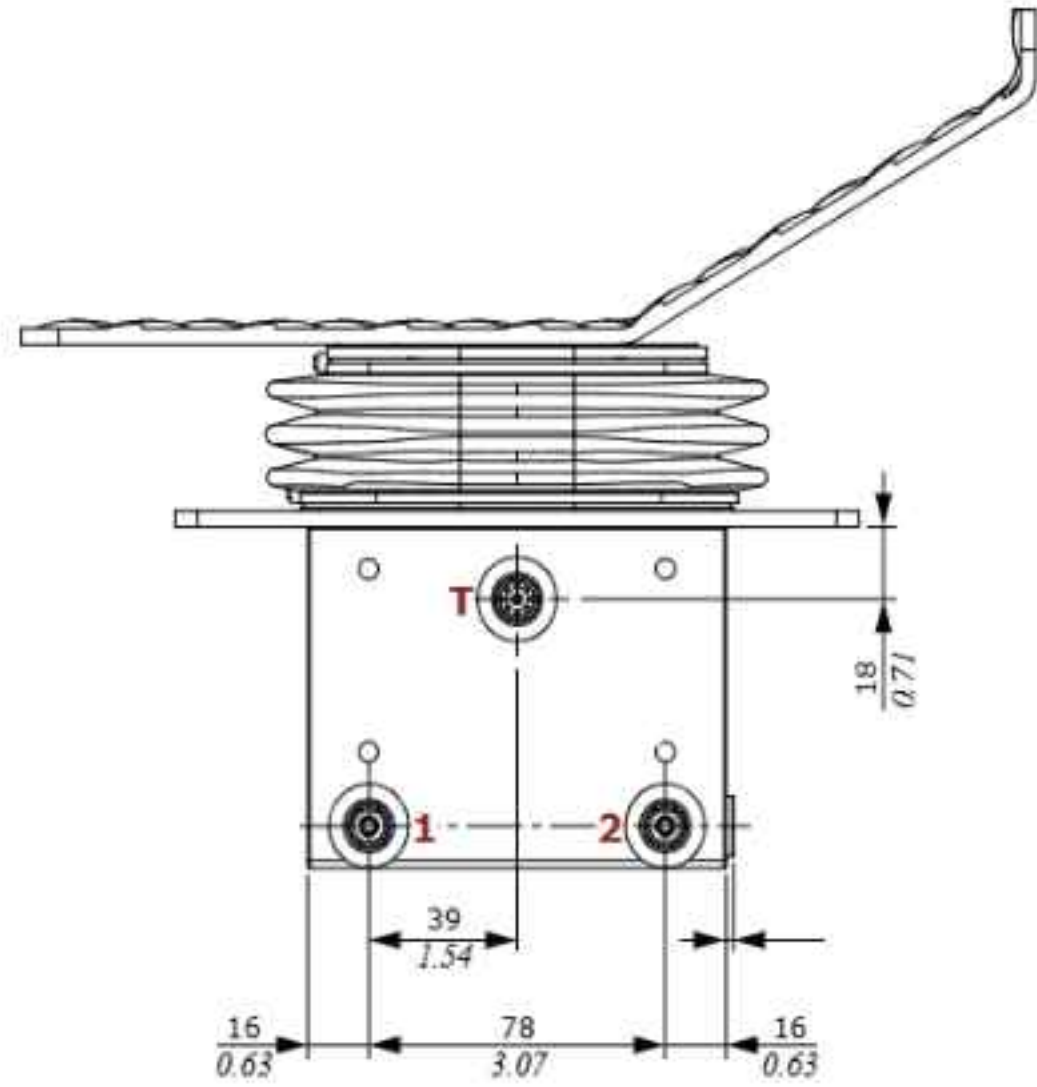
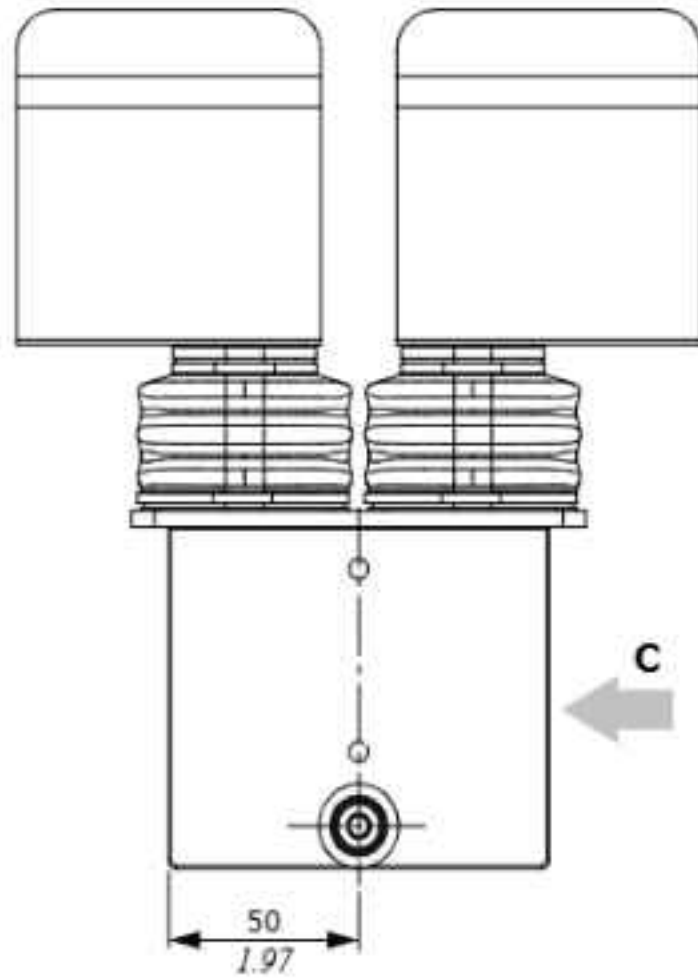

Hydraulic circuit

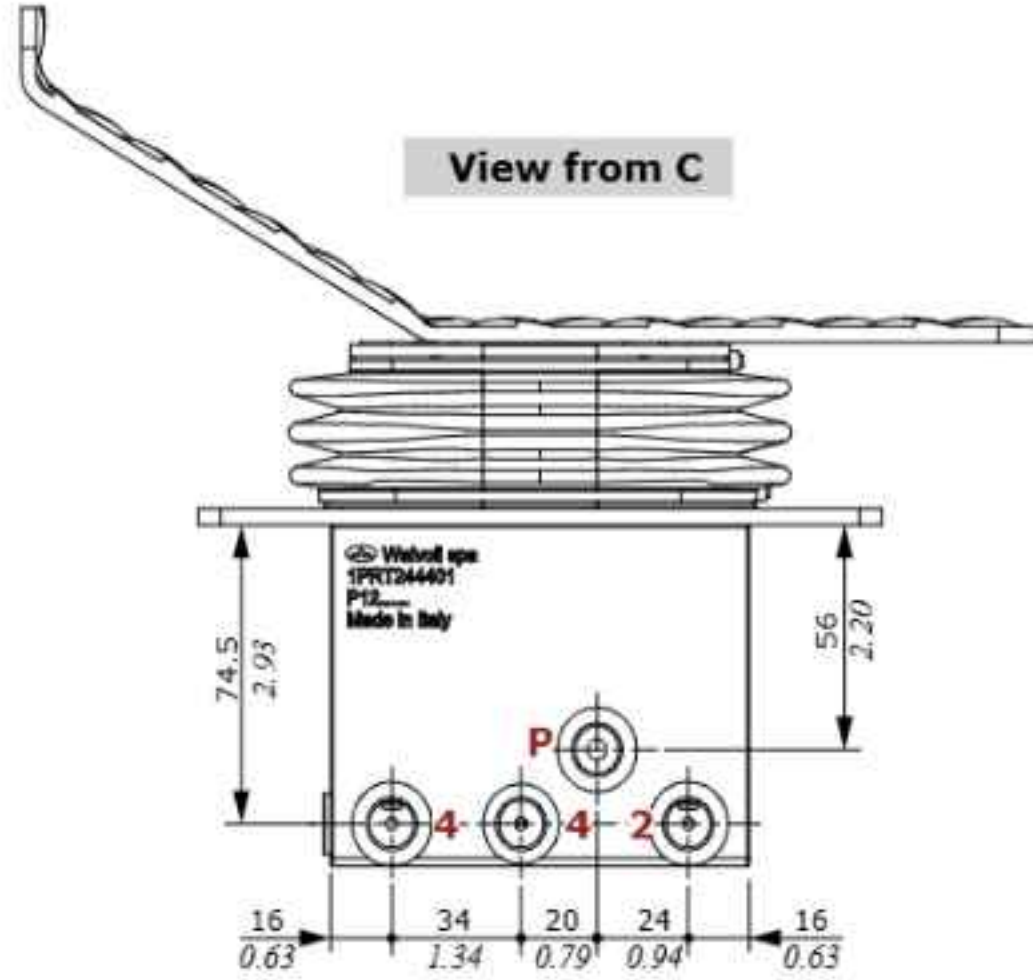
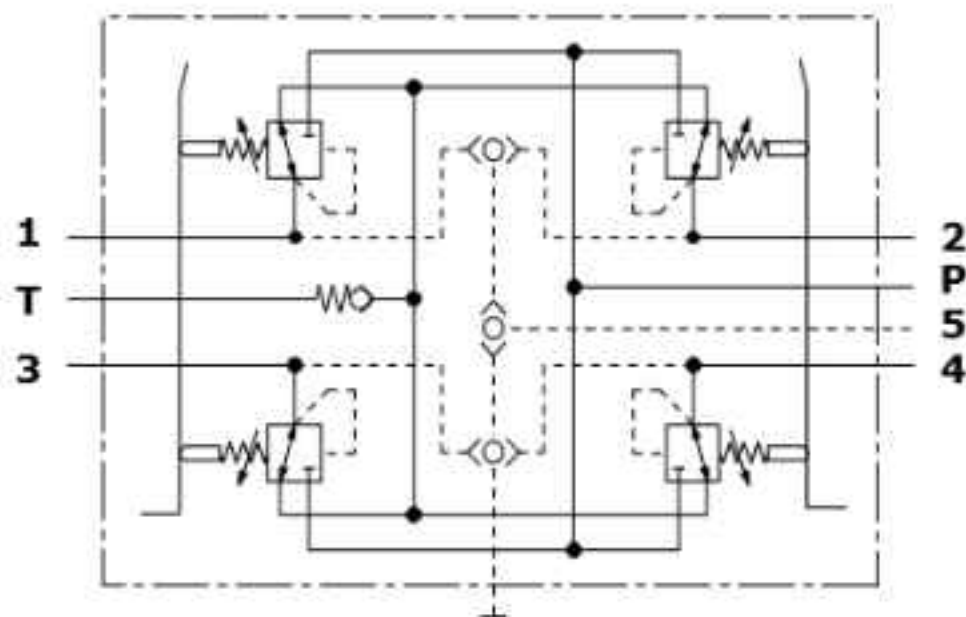

SVM540-B / 01 B3L - D 0 006N C X 2 / 01 B3R - D0006NC X 2 - VR
 1 2 3.1 3.2 3.3 3.4 2 3 check valve (always present)

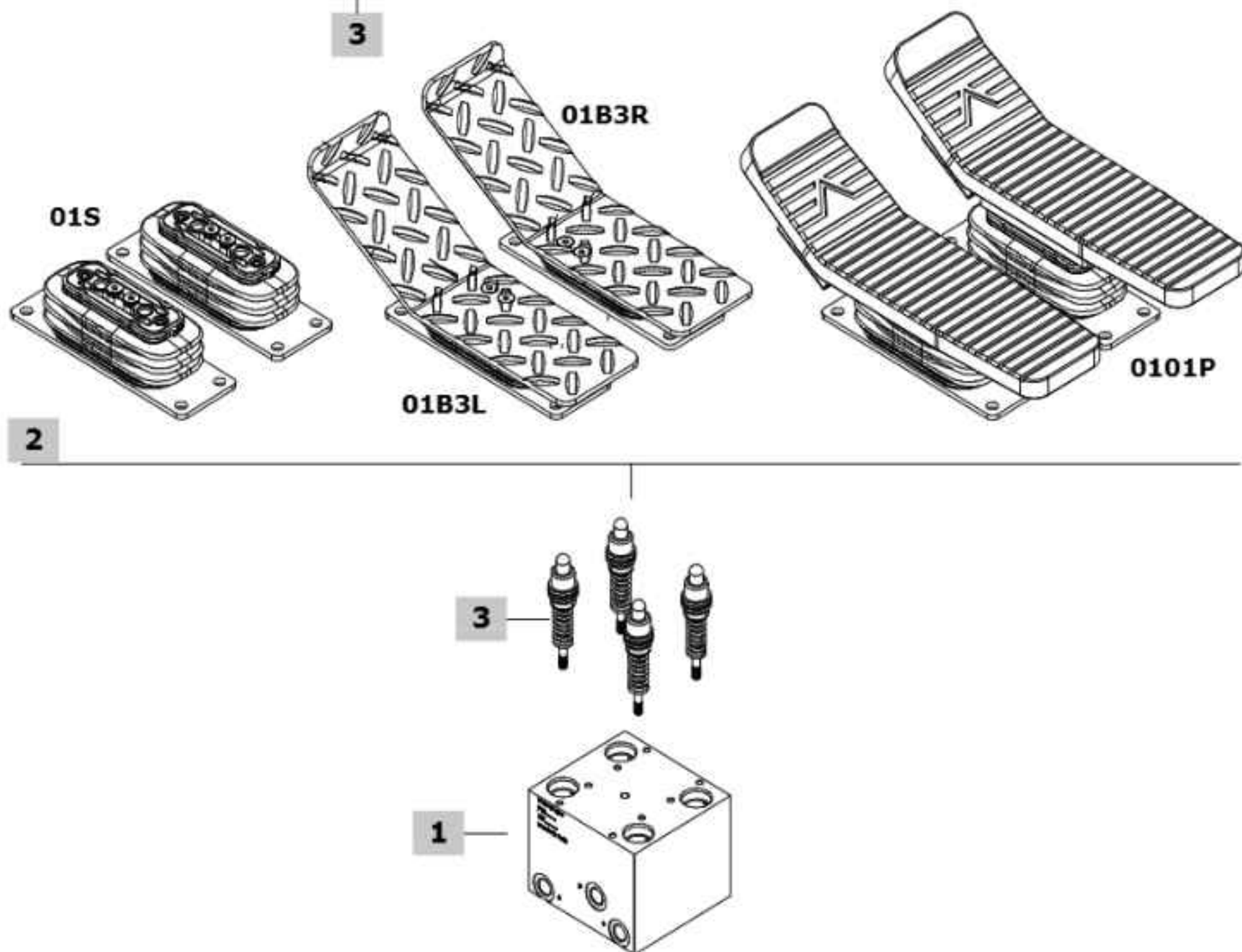

1 Body kit *

TYPE	CODE	DESCRIPTION
SVM540-B	5CO3540300	Pilot control valve body with check valve
SVM546-B	5CO3546300A	Pilot control valve body with check valve, shuttle valves and auxiliary port

2 Control options

TYPE	CODE	DESCRIPTION
01S	5CIN5001S	With spring return in neutral position and rubber bellow, without pedal
01B3L	5CIN5001B3L	As type 01S with 150° bent left pedal
01B3R	5CIN5001B3R	As previous one, right pedal
0101P	5CIN50001P01	As type 01S with 150° bent pedal and anti-slip rubber coating
0102P	5CIN50002P01	As type 01S with 150° bent and 30° tilted pedal, short type; anti-slip rubber coating
0103P	5CIN50003P01	As type 01S with 150° bent and 30° tilted pedal, long type; anti-slip rubber coating

3 Pressure control curves

For configuration and list available see from page 82

3.1 Curve type

TYPE	DESCRIPTION
D	With Damping

3.2 Typology of curves

TYPE	DESCRIPTION
0	With step
1	Without step

3.3 Curve identification

Progressive number

3.4 Return springs

TYPE	DESCRIPTION
A	Operation range from 23 to 35.2 N - from 5.17 to 7.91 lbf
B	Operation range from 23 to 68.1 N - from 5.17 to 15.31 lbf
C	Operation range from 89 to 176 N - from 20 to 39.56 lbf
D	Operation range from 110 to 220 N - from 24.73 to 49.46 lbf
E	Operation range from 138 to 276 N - from 31 to 62.04 lbf

NOTE (*) - Codes are referred to BSP thread.

Control options

01S type

With spring return in neutral position without pedal.

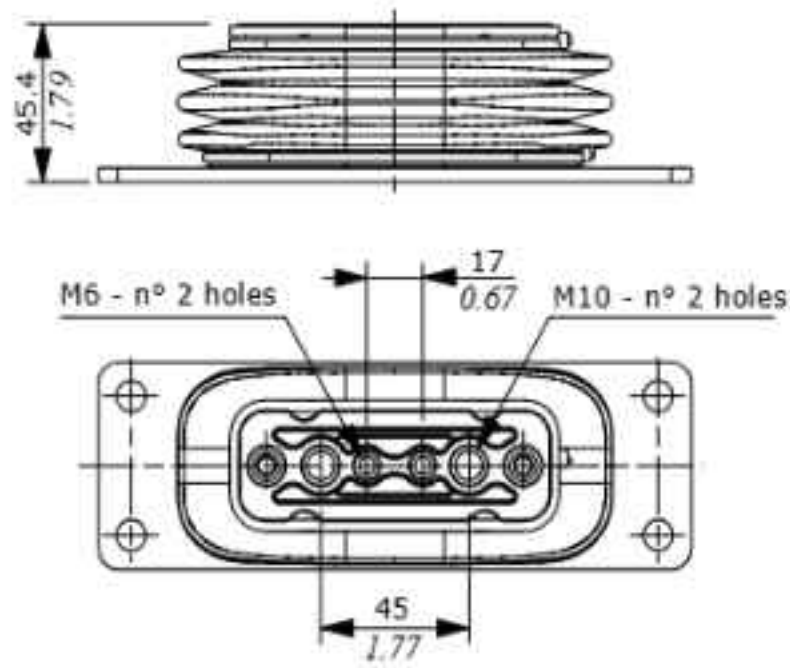

0101P type

With spring return in neutral position.
Bent pedal with anti-slip rubber coating.

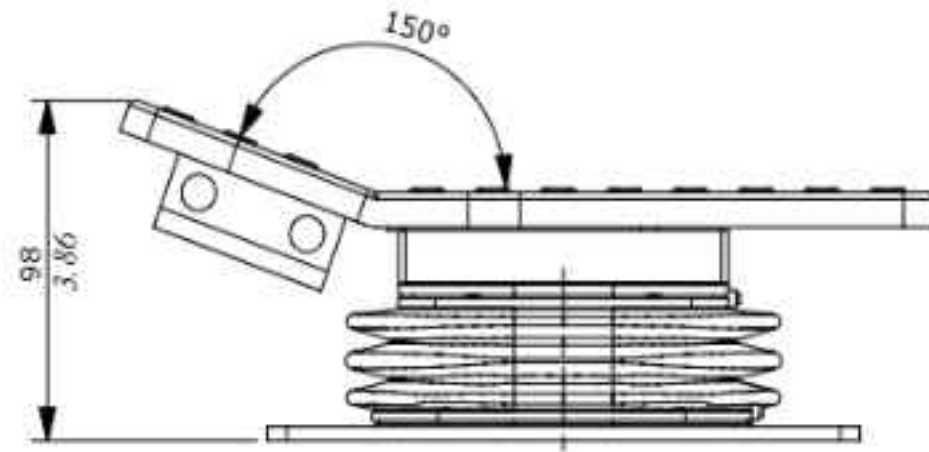

0101P assembly on the right

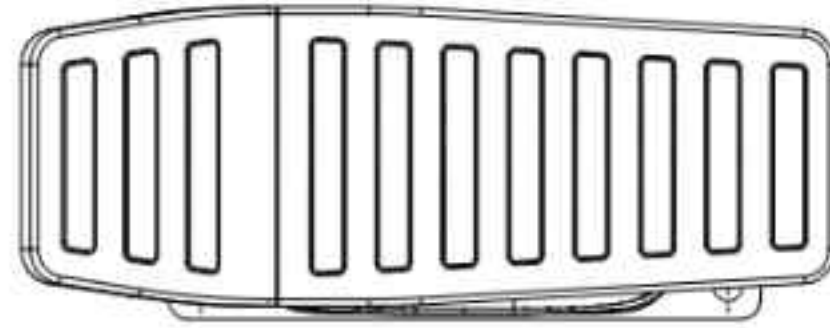

0101P assembly on the left

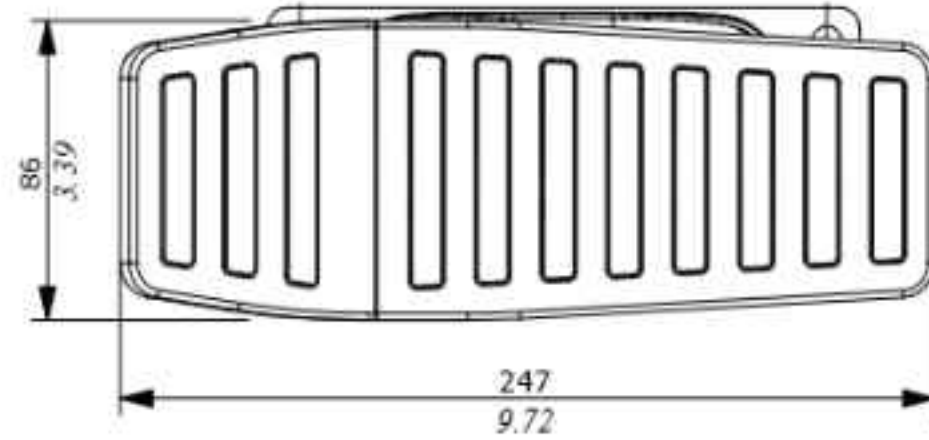

01B3 type

With spring return in neutral position.
Flat and shaped pedal with corrugated sheet, white galvanized.

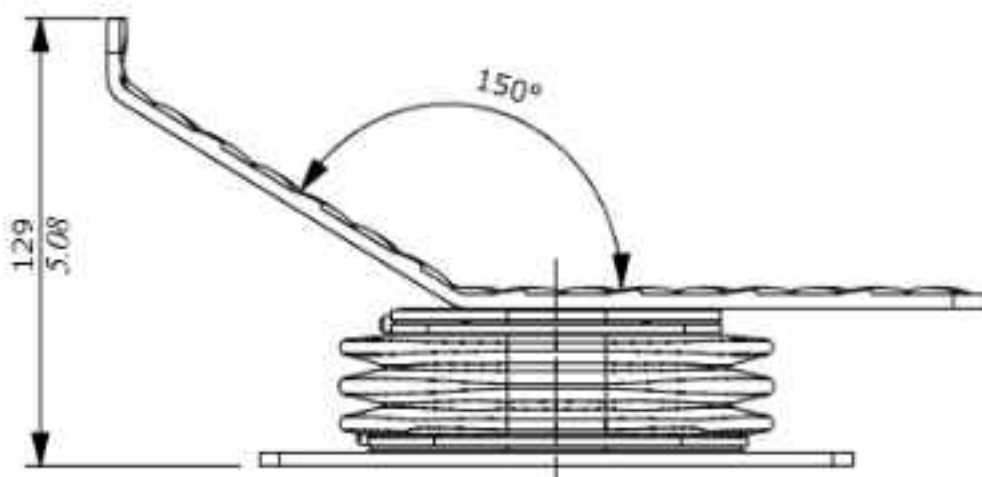

Right pedal 01B3R type

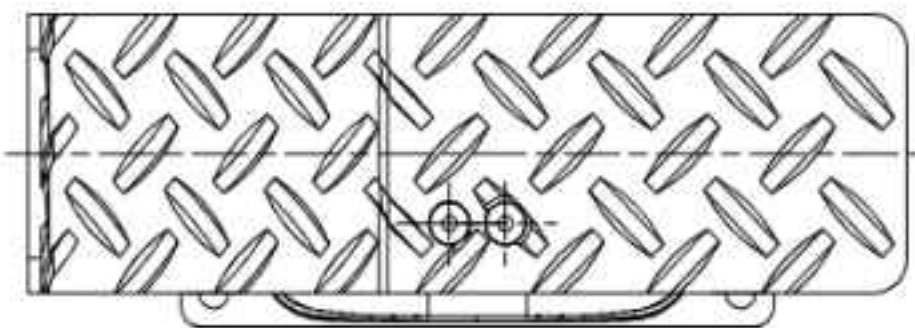

Left pedal 01B3L type

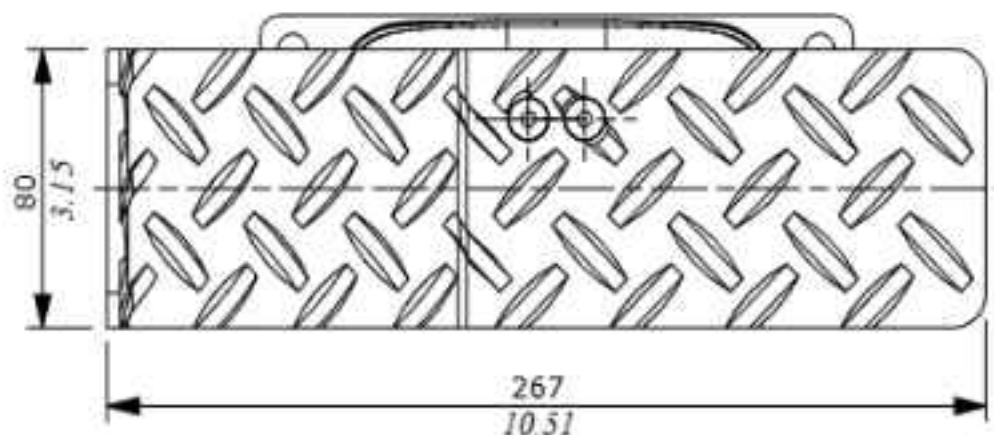

0102P type

With spring return in neutral position.
Bent and tilted pedal with anti-slip rubber coating, short model

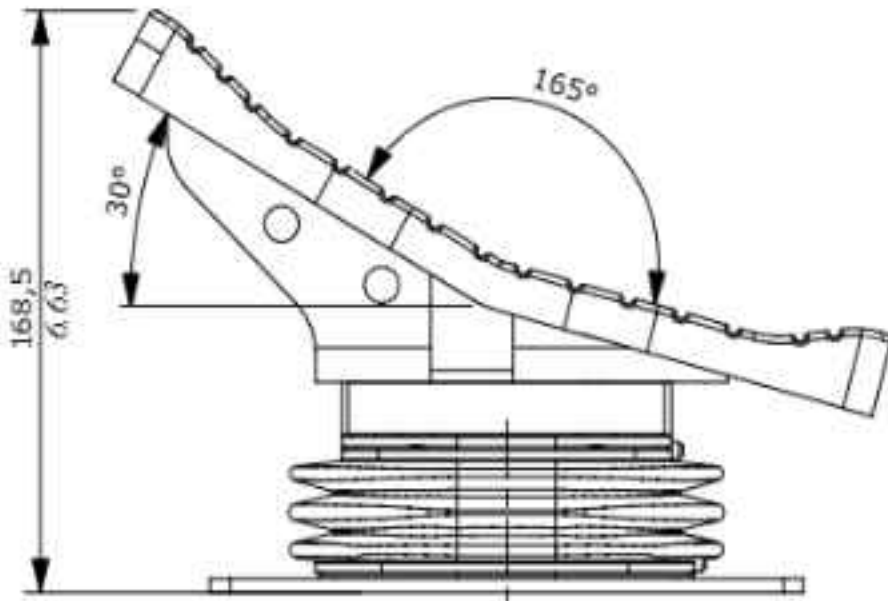

0102P assembly on the right

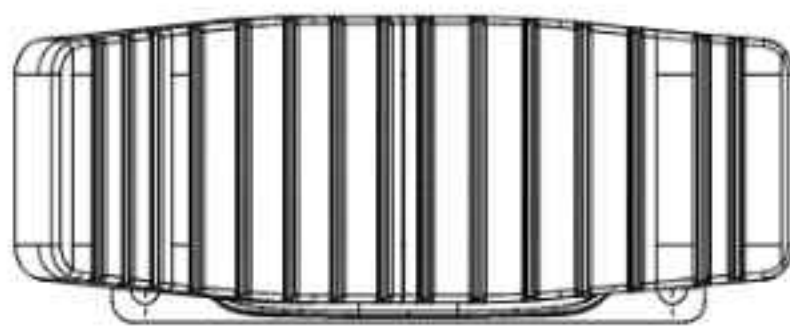

0102P assembly on the left

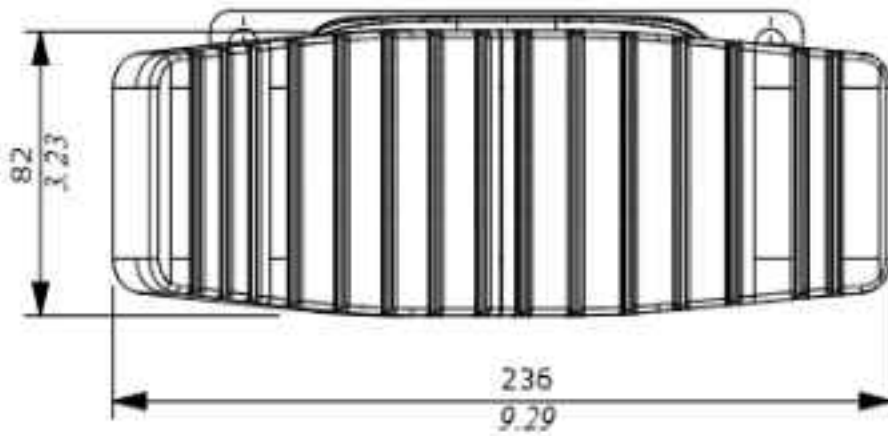

0103P type

With spring return in neutral position.
Bent and tilted pedal with anti-slip rubber coating, long model

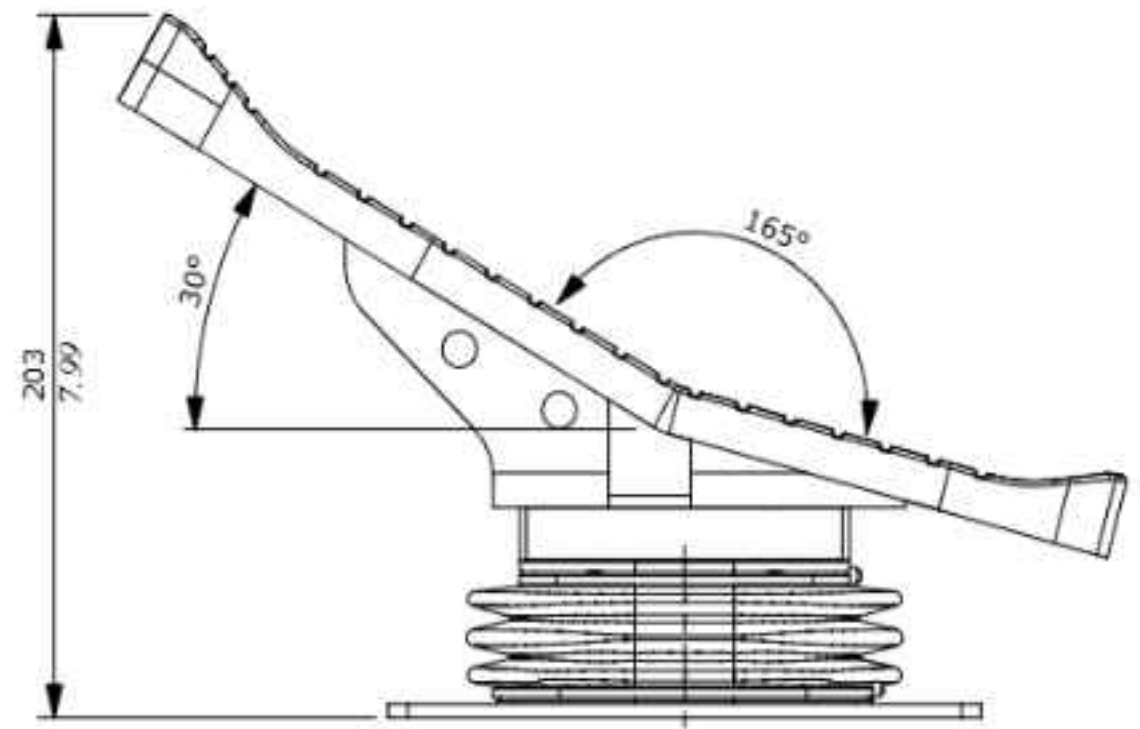

0103P assembly on the right

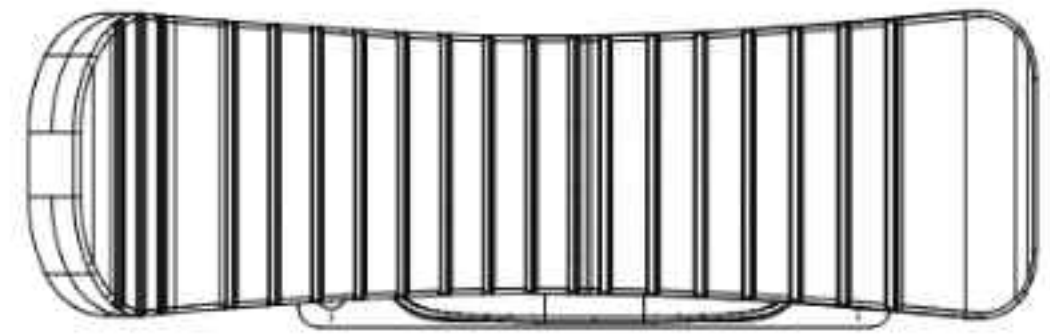

0103P assembly on the left

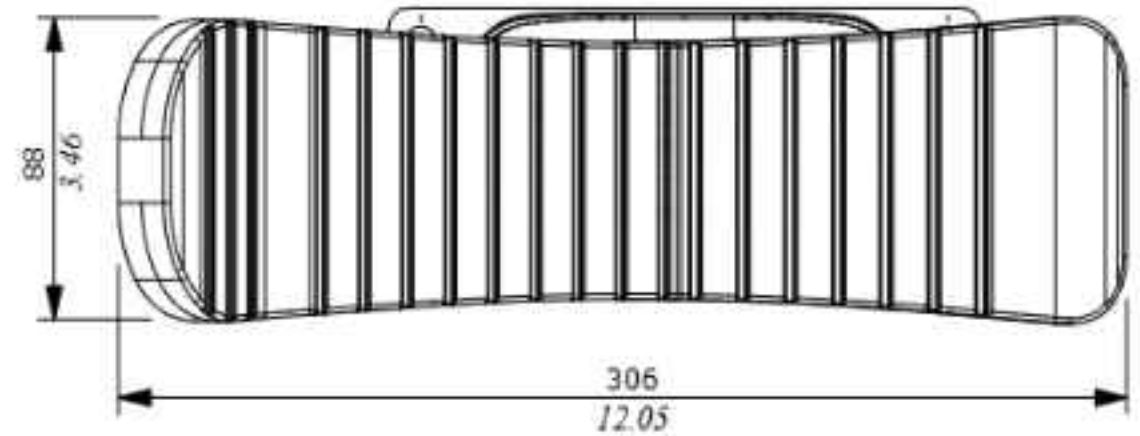

Dimension and hydraulic circuit

SVM702 type

Configuration with handweel operating.

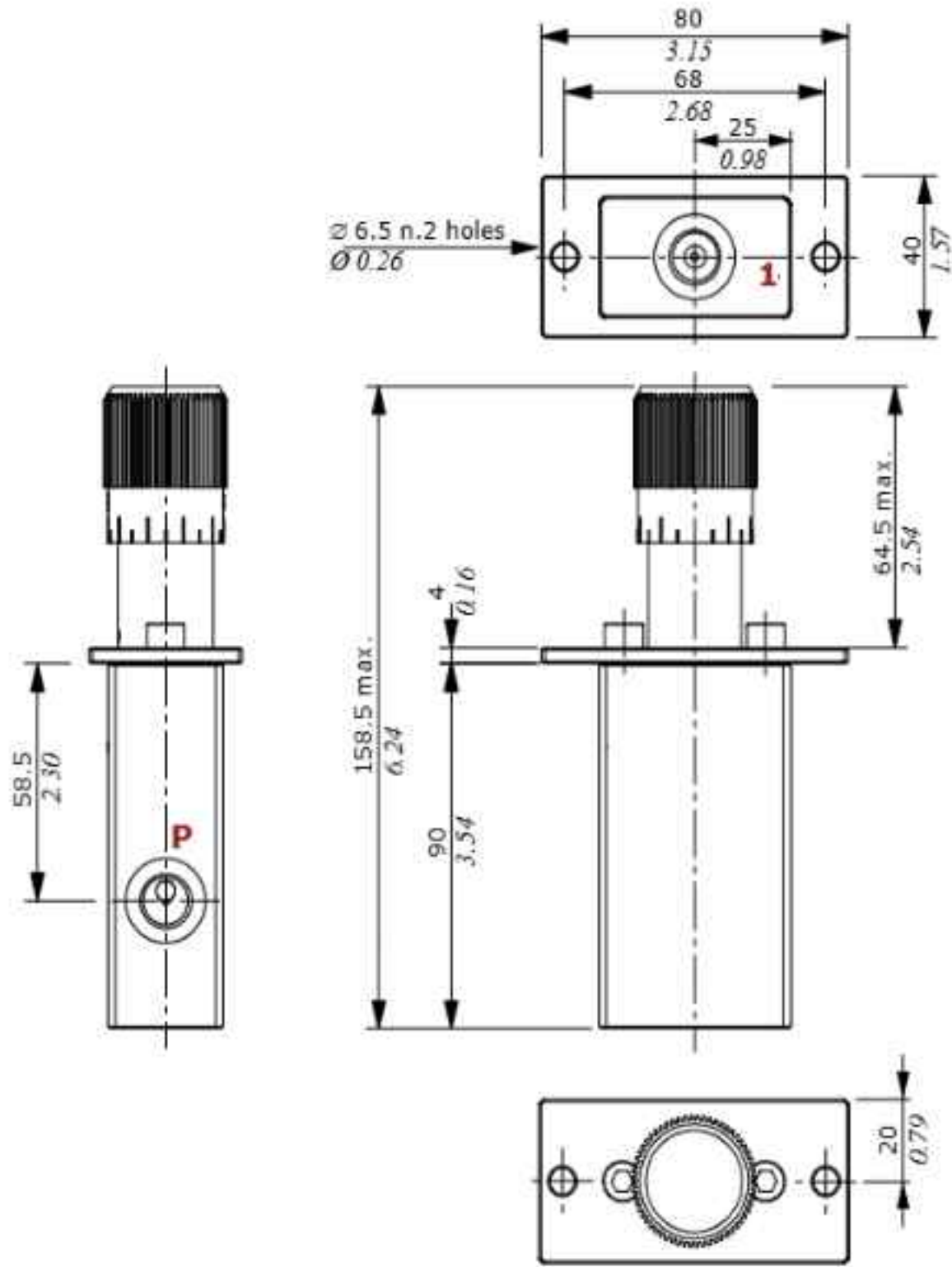

Hydraulic circuit

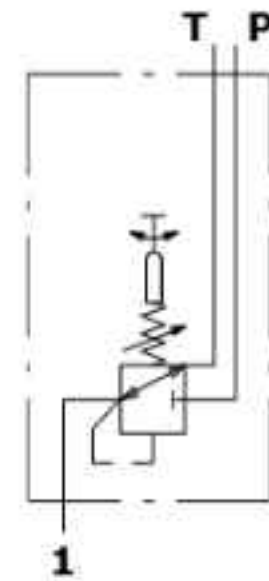

SVM710 type

Configuration with pusher operating.

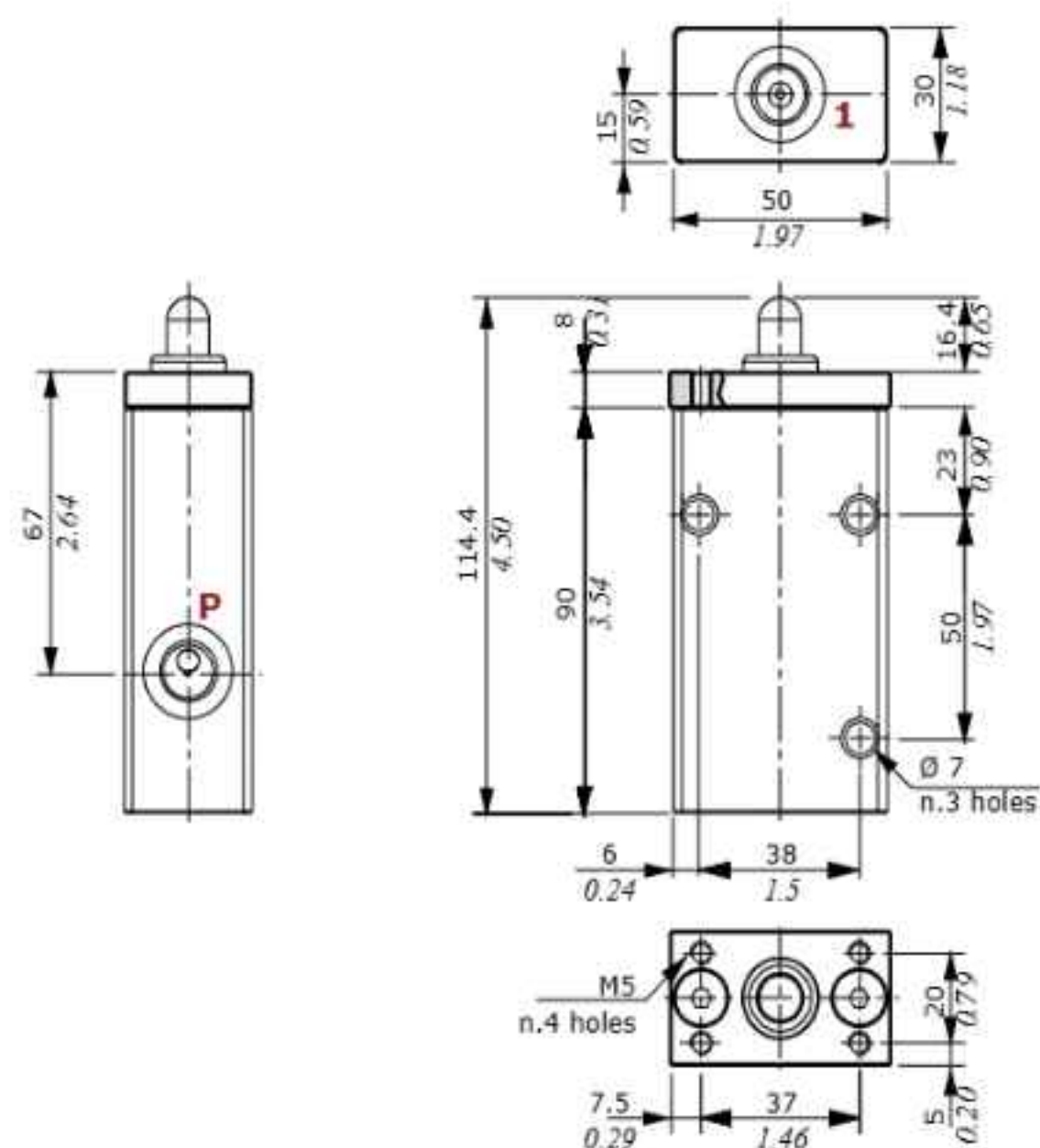

Hydraulic circuit

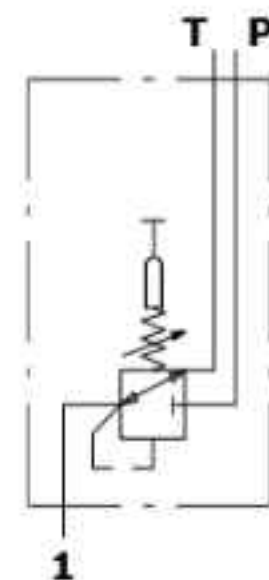

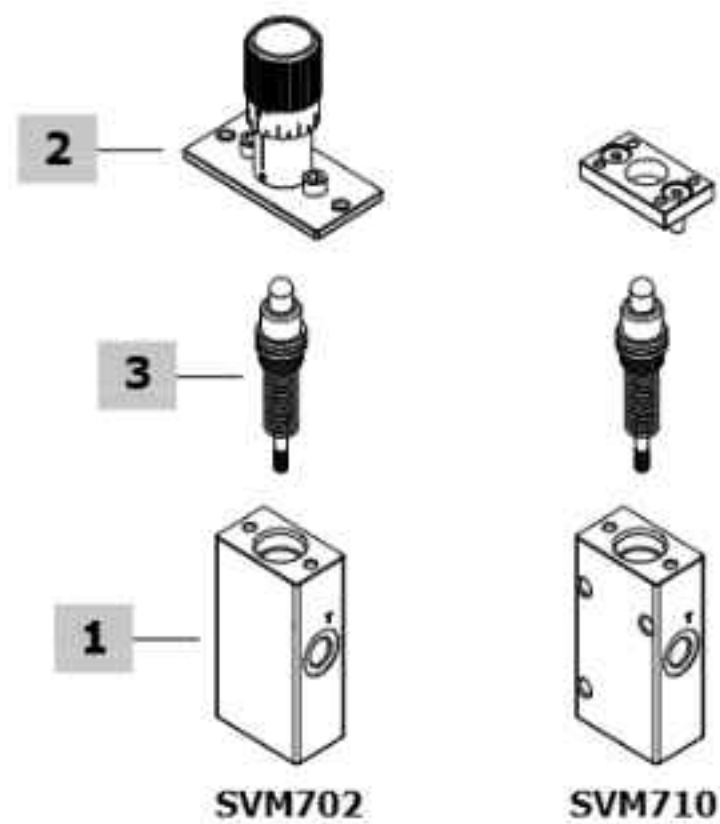
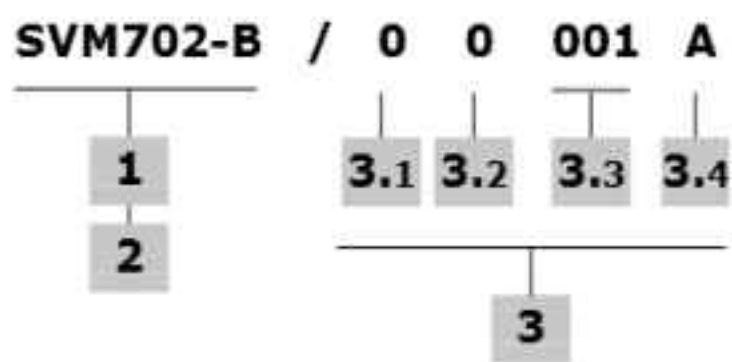

1 Body kit *

TYPE	CODE	DESCRIPTION
SVM702	3C03710300	Body kit
SVM710	3C03710310	Body kit

2 Control option

TYPE	CODE	DESCRIPTION
SVM702	5CIN702000	With aluminum handweel operating
SVM710	5CIN7011	Pusher operating and protection flange

3 Pressure control curves

For configuration and list available see from page 82

3.1 Curve type

TYPE	DESCRIPTION
0	Standard

3.2 Typology of curves

TYPE	DESCRIPTION
0	With step
1	Without step

3.3 Curve identification

Progressive number

3.4 Return springs

TYPE	DESCRIPTION
A	Operation range from 23 to 35.2 N - <i>from 5.17 to 7.91 lbf</i>
B	Operation range from 23 to 68.1 N - <i>from 5.17 to 15.31 lbf</i>
C	Operation range from 89 to 176 N - <i>from 20 to 39.56 lbf</i>
D	Operation range from 110 to 220 N - <i>from 24.73 to 49.46 lbf</i>
E	Operation range from 138 to 276 N - <i>from 31 to 62.04 lbf</i>

NOTE (*) - Codes are referred to **BSP** thread.

Control curves with step

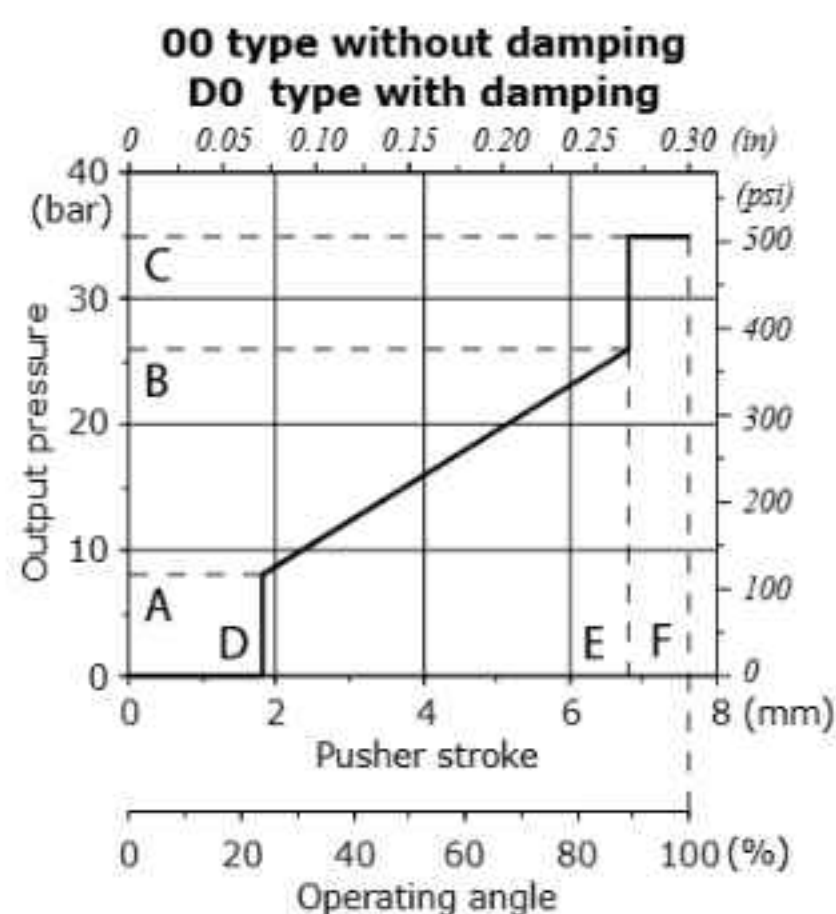

Curve description		Pressure						Stroke						CODE ⁽¹⁾
Type	Nr	A		B		C		D		E		F		
		bar (\pm toll)	psi (\pm toll)	bar (\pm toll)	psi (\pm toll)	bar	psi	mm	in	mm	in	mm	in	
Without damping														
00	019	0.5 (+1 -0.5)	7.25 (+14.5, -7.25)	11.4 (\pm 1)	165.3 (\pm 14.5)	35	507.5	0.85	0.03	7.25	0.28	7.6	0.30	5CR400019A
00	022	1 (\pm 0.5)	14.5 (\pm 7.25)	8 (\pm 1)	116.3 (\pm 14.5)	35	507.5	0.85	0.03	7.25	0.28	7.6	0.30	5CUR40022A
00	023	2 (\pm 0.5)	29 (\pm 7.25)	11.5 (\pm 1)	166.7 (\pm 14.5)	35	507.5	0.85	0.03	7.25	0.28	7.6	0.30	5CUR40023A
00	047	2 (+3/0)	29 (+43.5/0)	70 (\pm 4.5)	1015 (\pm 65.2)	35	507.5	0.85	0.03	7.25	0.28	7.6	0.30	5CUR40047A 5CUR40047C
00	065	2 (\pm 0.5)	29 (\pm 7.25)	20.5 (\pm 1.5)	297.25 (\pm 21.7)	35	507.5	0.85	0.03	7.25	0.28	7.6	0.30	5CUR40065A
00	066	2 (\pm 0.5)	29 (\pm 7.25)	23 (\pm 1.5)	333.5 (\pm 21.7)	35	507.5	0.85	0.03	7.25	0.28	7.6	0.30	5CUR40066B 5CUR40066C
00	110	2 (\pm 0.5)	29 (\pm 7.25)	15 (\pm 1)	217.5 (\pm 14.5)	35	507.5	0.85	0.03	7.25	0.28	7.6	0.30	5CR400110A
00	043	3.2 (\pm 0.5)	46.4 (\pm 7.25)	11.7 (\pm 0.5)	169.6 (\pm 7.25)	35	507.5	0.85	0.03	7.25	0.28	7.6	0.30	5CR400043A
00	010	3.25 (\pm 0.5)	74.13 (\pm 7.25)	14.8 (\pm 1)	214.6 (\pm 14.5)	35	507.5	0.85	0.03	7.25	0.28	7.6	0.30	5CUR40010A 5CUR40010M
00	032	3.4 (\pm 0.5)	49.3 (\pm 7.25)	29.4 (\pm 1)	426.3 (\pm 14.5)	35	507.5	0.85	0.03	7.25	0.28	7.6	0.30	5CUR40032A 5CUR40032B 5CUR40032C
00	086	4 (\pm 1)	58 (\pm 14.5)	16.5 (\pm 1)	239.2 (\pm 14.5)	35	507.5	0.85	0.03	7.25	0.28	7.6	0.30	5CUR40086A 5CUR40086C
00	073	4 (\pm 0.5)	58 (\pm 7.25)	18 (\pm 1)	261 (\pm 14.5)	35	507.5	0.85	0.03	7.25	0.28	7.6	0.30	5CR400073A 5CR400073M
00	020	4.3 (\pm 0.5)	63.3 (\pm 7.25)	15.2 (\pm 1)	220.4 (\pm 14.5)	35	507.5	0.85	0.03	7.25	0.28	7.6	0.30	5CUR40020A 5CUR40020B 5CUR40020C
00	004	4.9 (\pm 0.5)	72.5 (\pm 7.25)	18.9 (\pm 1)	274 (\pm 14.5)	35	507.5	0.85	0.03	7.25	0.28	7.6	0.30	5CUR40004A 5CUR40004C 5CUR40004M
00	017	5 (\pm 0.5)	72.5 (\pm 7.25)	12 (\pm 1)	174 (\pm 14.5)	35	507.5	0.85	0.03	7.25	0.28	7.6	0.30	5CUR40017A 5CUR40017C
00	028	5 (\pm 1)	72.5 (\pm 14.5)	21 (\pm 1.5)	304.5 (\pm 21.7)	35	507.5	0.85	0.03	7.25	0.28	7.6	0.30	5CUR40028A 5CUR40028B 5CUR40028C 5CUR40028M
00	071	5 (\pm 1)	72.5 (\pm 14.5)	17 (\pm 1)	246.5 (\pm 14.5)	35	507.5	1.35	0.05	6	0.23	7.3	0.29	5CUR40071A
00	075	5 (\pm 0.5)	72.5 (\pm 7.25)	15 (\pm 1.5)	217.5 (\pm 21.7)	35	507.5	0.85	0.03	7.25	0.28	7.6	0.30	5CUR40075A 5CUR40075B 5CUR40075C 5CUR40075E 5CUR40075M
00	104	5.5 (\pm 1)	79.75 (\pm 14.5)	17 (\pm 1)	246.5 (\pm 14.5)	35	507.5	0.85	0.03	3.1	0.12	3.5	0.14	5CR400104A
00	115	5.5		28.5				0.85	0.03	5.6	0.22	6.1	0.24	5CUR40115M
00	001	5.8 (\pm 1)	84.1 (\pm 14.5)	22 (\pm 2)	319 (\pm 29)	35	507.5	1.55	0.06	7	0.27	7.5	0.29	5CUR40001A

Control curves with step

Curve description		Pressure						Stroke						CODE ⁽¹⁾
Type	Nr	A		B		C		D		E		F		
		bar (\pm toll)	psi (\pm toll)	bar (\pm toll)	psi (\pm toll)	bar	psi	mm	in	mm	in	mm	in	
00	024	5.8 (\pm 1)	84.1 (\pm 14.5)	19 (\pm 1.5)	275.5 (\pm 21.7)	35	507.5	1.55	0.06	6.1	0.24	7.5	0.29	5CUR40024A 5CUR40024C
00	033	5.8 (\pm 0.5)	84.1 (\pm 7.25)	19 (\pm 1)	275.5 (\pm 14.5)	35	507.5	0.85	0.03	7.25	0.28	7.6	0.30	5CUR40033A 5CUR40033B 5CUR40033C 5CUR40033M
00	070	5.8 (\pm 1)	84.1 (\pm 14.5)	22.4 (\pm 2)	324.8 (\pm 29)	35	507.5	0.85	0.03	7.25	0.28	7.6	0.30	5CUR40070A 5CUR40070B 5CUR40070D 5CUR40070M
00	087	5.8 (\pm 0.5)	84.1 (\pm 7.25)	17 (\pm 1.5)	246.5 (\pm 21.7)	35	507.5	0.85	0.03	7.25	0.28	7.6	0.30	5CUR40087A
00	021	6 (\pm 0.5)	87 (\pm 7.25)	16.3 (\pm 1)	236.4 (\pm 14.5)	35	507.5	0.85	0.03	7.25	0.28	7.6	0.30	5CR400021A 5CR400021M
00	105	6 (\pm 0.5)	87 (\pm 7.25)	20 (\pm 1)	290 (\pm 14.5)	35	507.5	0.6	0.02	7.25	0.28	7.6	0.30	5CR400105B
00	054	6.2 (\pm 1)	89.9 (\pm 14.5)	24.5 (\pm 2)	355.25 (\pm 29)	35	507.5	0.85	0.03	7.25	0.28	7.6	0.30	5CUR40054A
00	007	6.5 (\pm 1)	94.25 (\pm 14.5)	36 (\pm 2)	522 (\pm 29)	35	507.5	0.85	0.03	7.25	0.28	7.6	0.30	5CR400007A
00	026	6.5 (\pm 0.5)	94.25 (\pm 7.25)	14 (\pm 1)	203 (\pm 14.5)	35	507.5	0.85	0.03	7.25	0.28	7.6	0.30	5CUR40026A 5CUR40026B 5CUR40026C
00	053	8 (\pm 0.5)	116 (\pm 7.25)	22.3 (\pm 1)	323.3 (\pm 14.5)	35	507.5	0.85	0.03	7.25	0.28	7.6	0.30	5CUR40053A
00	088	8 (\pm 0.5)	116 (\pm 7.25)	27 (\pm 1.5)	391.5 (\pm 21.7)	35	507.5	0.85	0.03	7.25	0.28	7.6	0.30	5CUR40088A 5CUR40088B 5CUR40088C 5CUR40088M
00	089	8 (\pm 0.5)	116 (\pm 7.25)	28 (\pm 1)	406 (\pm 14.5)	35	507.5	0.85	0.03	7.25	0.28	7.6	0.30	5CUR40089A 5CUR40089C 5CUR40089D 5CUR40089M
00	112	8 (\pm 1.5)	116 (\pm 21.7)	54 (\pm 3.5)	783 (\pm 50.75)	60	870	0.85	0.03	7.25	0.28	7.6	0.30	5CR400112A
00	122	10 (\pm 1)	145 (\pm 14.5)	27 (\pm 2)	391.5 (\pm 29)	35	507.5	0.85	0.03	7.25	0.28	7.6	0.30	5CR400122C
00	124	10 (\pm 1)	145 (\pm 14.5)	25 (\pm 1.5)	362.5 (\pm 21.7)	35	507.5	0.85	0.03	7.25	0.28	7.6	0.30	5CR400124A
00	036	12 (\pm 0.5)	174 (\pm 7.25)	25 (\pm 1)	362.5 (\pm 14.5)	35	507.5	0.85	0.03	7.25	0.28	7.6	0.30	5CUR40036A
00	107	12 (\pm 1)	174 (\pm 14.5)	20 (\pm 1)	290 (\pm 14.5)	35	507.5	0.85	0.03	7.25	0.28	7.6	0.30	5CR400107A
00	012	14 (\pm 1)	203 (\pm 14.5)	28.5 (\pm 1.5)	413.25 (\pm 21.7)	35	507.5	0.85	0.03	7.25	0.28	7.6	0.30	5CR400012A
00	038	22 (\pm 2)	319 (\pm 29)	37 (\pm 3)	536.5 (\pm 43.5)	35	507.5	0.85	0.03	7.25	0.28	7.6	0.30	5CUR40038C 5CUR40038M
With damping														
D0	020	4.3 (\pm 0.5)	62.3 (\pm 7.25)	15.2 (\pm 1.5)	220.4 (\pm 21.7)	35	507.5	0.85	0.03	7.25	0.28	7.6	0.30	5CUR4D020C
D0	004	4.9 (\pm 0.5)	72.5 (\pm 7.25)	18.9 (\pm 1)	274 (\pm 14.5)	35	507.5	0.85	0.03	7.25	0.28	7.6	0.30	5CR4D0004C
D0	075	5 (\pm 0.5)	72.5 (\pm 7.25)	15 (\pm 1.5)	217.5 (\pm 21.7)	35	507.5	0.85	0.03	7.25	0.28	7.6	0.30	5CUR4D075C
D0	028	5 (\pm 1)	72.5 (\pm 14.5)	21 (\pm 1.5)	304.5 (\pm 21.7)	35	507.5	0.85	0.03	7.25	0.28	7.6	0.30	5CR7D0028NM
D0	085	6 (\pm 1)	87 (\pm 14.5)	25 (\pm 1.5)	362.5 (\pm 21.7)	35	507.5	0.85	0.03	7.25	0.28	7.6	0.30	5CUR4D085C
D0	088	8 (\pm 0.5)	116 (\pm 7.25)	27 (\pm 1.5)	391.5 (\pm 21.7)	35	507.5	0.85	0.03	7.25	0.28	7.6	0.30	5CUR4D088A 5CUR4D088C
D0	089	8 (\pm 0.5)	116 (\pm 7.25)	28 (\pm 1)	406 (\pm 14.5)	35	507.5	0.85	0.03	7.25	0.28	7.6	0.30	5CUR4D089C 5CUR4D089D

⁽¹⁾ Codes are referred to the curve with the specific return spring
For different curves please contact our Sales Department

List continues in the next page

Control curves without step

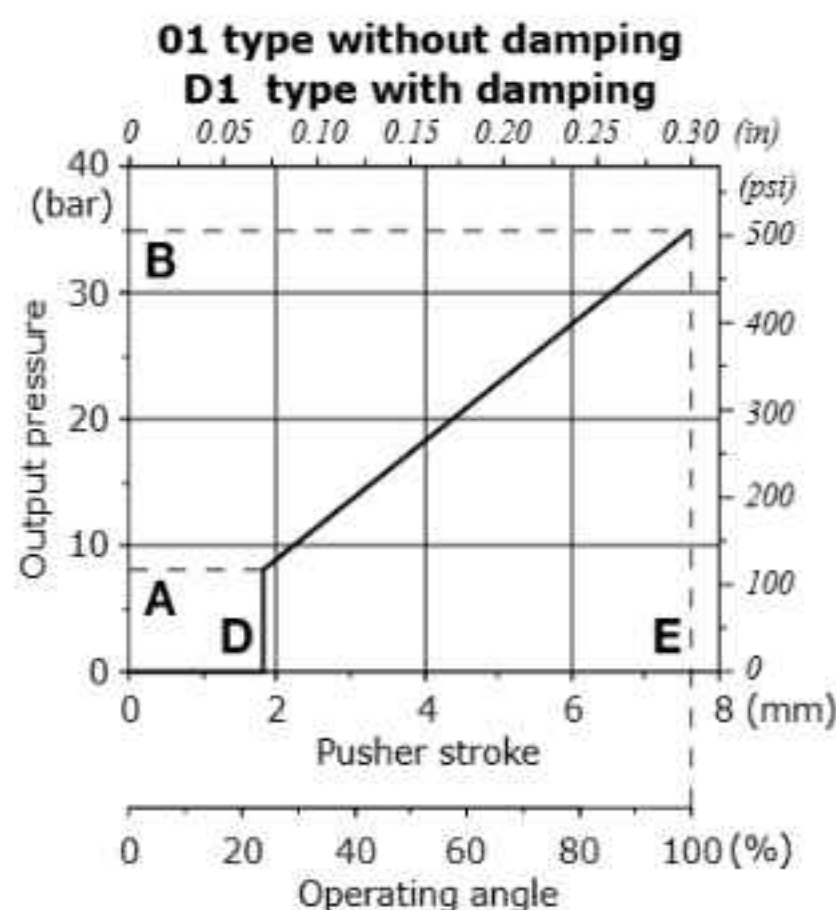

Curve description		Pressure				Stroke				CODE ⁽¹⁾
Type	Nr	A		B		D		E		
		bar (\pm toll)	psi (\pm toll)	bar (\pm toll)	psi (\pm toll)	mm	in	mm	in	
Without pre-feeling										
01	148	0 (+0.5)	0 (\pm 7.25)	13 (\pm 1)	188.5 (\pm 14.5)	0.85	0.03	7.6	0.30	5CUR40148B
01	151	0 (+1)	0 (+14.5)	41 (\pm 2)	594.5 (\pm 29)	1	0.04	5.4	0.21	5CR401151C
01	099	1 (\pm 0.5)	14.5 (\pm 7.25)	20 (\pm 1.5)	290 (\pm 21.7)	1.55	0.06	7.5	0.29	5CR401099A
01	131	1 (\pm 1)	14.5 (\pm 14.5)	15 (\pm 1)	217.5 (\pm 14.5)	0.85	0.03	7.6	0.30	5CUR40131A 5CUR40131C
01	100	1.2 (\pm 0.5)	17.4 (\pm 7.25)	18.9 (\pm 1)	274 (\pm 14.5)	0.85	0.03	7.6	0.30	5CUR40100B 5CUR40100M
01	163	1.4 (\pm 0.5)	20.3 (\pm 7.25)	11.5 (\pm 1)	166.8 (\pm 14.5)	0.85	0.03	7.6	0.30	5CUR40163A 5CUR40163M
01	105	2 (\pm 0.5)	29 (\pm 7.25)	8 (\pm 1)	116 (\pm 14.5)	0.85	0.03	7.6	0.30	5CUR40105A
01	129	2 (\pm 0.5)	29 (\pm 7.25)	66 (\pm 4)	957 (\pm 58)	0.85	0.03	6.8	0.28	5CUR40129A
01	154	2 (\pm 0.5)	29 (\pm 7.25)	15 (\pm 1)	217.5 (\pm 14.5)	0.85	0.03	7.6	0.30	5CUR40154A 5CUR40154M
01	138	2.5 (\pm 0.5)	36.2 (\pm 7.25)	13 (\pm 1)	188.5 (\pm 14.5)	0.85	0.03	7.6	0.30	5CUR40138A
01	143	3 (\pm 0.5)	43.5 (\pm 7.25)	25 (\pm 1)	362.5 (\pm 14.5)	0.85	0.03	7.6	0.30	5CUR40143A
01	127	3.4 (\pm 0.5)	49.3 (\pm 7.25)	12 (\pm 1)	174 (\pm 14.5)	0.85	0.03	7.6	0.30	5CUR40127A 5CUR40127B
01	157	3.4 (\pm 1)	49.3 (\pm 14.5)	17.2 (\pm 1)	249.4 (\pm 14.5)	0.85	0.03	7.6	0.30	5CUR40157A 5CUR40157B
01	114	4 (\pm 0.5)	58 (\pm 7.25)	10 (\pm 1)	145 (\pm 14.5)	0.85	0.03	7.6	0.30	5CUR40114A 5CUR40114B 5CUR40114M
01	126	4.5 (\pm 0.7)	65.2 (\pm 10.1)	30.7 (\pm 1.5)	445.1 (\pm 21.7)	0.85	0.03	7.6	0.30	5CUR40126A
01	170	5 (\pm 0.5)	72.5 (\pm 7.25)	20 (\pm 1)	290 (\pm 14.5)	0.85	0.03	7.6	0.30	5CUR40170A 5CUR40170M
01	175	5 (\pm 0.5)	72.5 (\pm 7.25)	16 (\pm 1.5)	232 (\pm 21.7)	0.85	0.03	7.6	0.30	5CUR40175A 5CUR40175D
01	111	5.5 (\pm 0.5)	88 (\pm 7.25)	25.5 (\pm 1)	370 (\pm 14.5)	0.85	0.03	7.6	0.30	5CUR40111A 5CUR40111B 5CUR40111C
01	118	5.8 (\pm 1)	84.1 (\pm 14.5)	19.5 (\pm 1.5)	282.7 (\pm 21.7)	1.55	0.06	7.5	0.29	5CUR40118A
01	135	5.8 (\pm 0.5)	84.1 (\pm 7.25)	23 (\pm 1.5)	333.5 (\pm 21.7)	0.85	0.03	7.6	0.30	5CUR40135A 5CUR40135M
01	167	6 (\pm 0.5)	87 (\pm 7.25)	18 (\pm 1)	261 (\pm 14.5)	0.85	0.03	7.6	0.30	5CUR40167M
01	103	6 (\pm 1)	87 (\pm 14.5)	30 (\pm 2.5)	435 (\pm 36.2)	0.85	0.03	7.6	0.30	5CUR40103A 5CUR40103M
01	106	6 (\pm 1)	87 (\pm 14.5)	40 (\pm 2)	580 (\pm 29)	0.85	0.03	7.6	0.30	5CUR40106A 5CUR40106B 5CUR40106C

List continues in the next page

Control curves without step

Curve description		Pressure				Stroke				CODE ⁽¹⁾
		A		B		D		E		
Type	Nr	bar (\pm toll)	psi (\pm toll)	bar (\pm toll)	psi (\pm toll)	mm	in	mm	in	
01	095	6.5 (\pm 0.5)	94.25 (\pm 7.25)	17.8 (\pm 1)	258.1 (\pm 14.5)	0.85	0.03	7.6	0.30	5CR401095A
01	125	8 (\pm 0.5)	116 (\pm 7.25)	22.5 (\pm 1)	326.25 (\pm 14.5)	0.85	0.03	7.6	0.30	5CUR40125M
01	115	8.3 (\pm 0.7)	120.3 (\pm 10.1)	22.5 (\pm 1)	326.2 (\pm 14.5)	0.85	0.03	7.6	0.30	5CUR40115M
01	159	10 (\pm 0.5)	145 (\pm 7.25)	28 (\pm 1)	406 (\pm 14.5)	0.85	0.03	7.6	0.30	5CUR401159A
01	090	12 (\pm 1)	174 (\pm 14.5)	18 (\pm 1)	261 (\pm 14.5)	0.85	0.03	7.6	0.30	5CR401090A
01	195	14 (\pm 1)	203 (\pm 14.5)	29.5 (\pm 1.5)	427.75 (\pm 21.7)	0.85	0.03	7.6	0.30	5CR401195A
01	144	35 (\pm 2)	507.5 (\pm 29)	70 (\pm 3.5)	1015 (\pm 50.7)	0.85	0.03	7.6	0.30	5CUR40144C
With damping										
D1	155	4.8 (\pm 1)	69.6 (\pm 14.5)	21.5 (\pm 1.5)	311.75 (\pm 21.7)	0.85	0.03	6.2	0.24	5CUR4D020C
D1	103	6 (\pm 1)	87 (\pm 14.5)	30 (\pm 2.5)	435 (\pm 36.25)	0.85	0.03	7.6	0.30	5CR4D1103NC
D1	091	7 (\pm 1)	101.5 (\pm 14.5)	27 (\pm 1)	391.5 (\pm 14.5)	0.85	0.03	7.6	0.30	5CR4D1091NC

⁽¹⁾ Codes are referred to the curve with the specific return spring
For different curves please contact our Sales Department





Feed units and accessories

- 2 Way series with or without unloader valve (AVN020)
- Range from 1 to 4 stages with and without accumulator
- Diverter valve for pilot hydraulic control system

AVN020 working conditions

This catalogue shows technical specifications and diagrams measured with mineral oil of 46mm²/s - 46 cSt viscosity at 40°C - 104°F temperature.

Max. pressure on inlet	on inlet, P port	350 bar - 5075 psi
Nominal secondary pressure		30 bar - 435 psi
Flow rating range		from 5 to 20 l/min - from 1.32 to 5.28 USgpm
Max. backpressure	to outlet, T port	3 bar - 43.5 psi
Fluid		mineral oil
Fluid temperature	with NBR (BUNA-N) seals	from -20°C to 80°C - from -4°F to 176°F
Viscosity	operating range	from 15 to 75 mm ² /s - from 15 to 75 cSt
	min.	12 mm ² /s - 12 cSt
	max.	400 mm ² /s - 400 cSt
Max. contamination level		-/19/16 - ISO 4406 - NAS1638 class 10
Ambient temperature	without electric devices	from -40°C to 60°C - from 40°F to 140°F
	with electric devices	from -20°C to 50°C - from -4°F to 122°F

NOTE - for different conditions please contact Sales Dpt

FU series working conditions

This catalogue shows technical specifications and diagrams measured with mineral oil of 46mm²/s - 46 cSt viscosity at 40°C - 104°F temperature.

	FU/1	FU/2	FU/3	FU/4
Max. pressure on inlet on inlet P port	350 bar - 5075 psi	210 bar - 3045 psi	350 bar - 5075 psi	350 bar - 5075 psi
Flow rating range	60 l/min - 15.85 USgpm	12 l/min - 3.17 USgpm	10 l/min - 2.64 USgpm	8 l/min - 2.11 USgpm
Fluid				mineral oil
Fluid temperature with NBR (BUNA-N) seals				from -20°C to 90°C - from -4°F to 194°F
operating range				from 15 to 75 mm ² /s - from 15 to 75 cSt
Viscosity	min.			20 mm ² /s - 20 cSt
	max.			200 mm ² /s - 200 cSt
Max. contamination level				18/16/13 - ISO 4406 - NAS1638 class 6
Ambient temperature	without electric devices			from -40°C to 60°C - from 40°F to 140°F
	with electric devices			from -20°C to 50°C - from -4°F to 122°F

NOTE - for different conditions, please contact our Sales Dpt

DHV080 working conditions

This catalogue shows technical specifications and diagrams measured with mineral oil of 46mm²/s - 46 cSt viscosity at 40°C - 104°F temperature.

Nominal flow rating	10 l/min - 2.64 Usrpm
Nominal pressure	100 bar - 1450 psi
Internal leakage (100 bar - 1450 psi)	10 cm ³ /min - 0.61 in ³ /min
Fluid	mineral oil
Viscosity (operating range)	from 12 to 400 mm ² /s - from 12 to 400 cSt
Max. contamination range	-/19/16 - ISO 4406 - NAS1638 class 10
Fluid temperature	from -20° C to 80°C - from -4° F to 176°F
Ambient temperature	from -40° C to 60°C - from 40° F to 140°F
Salt spray (fog) testing	(ISO9227) 70 h

NOTE - for different conditions please contact Sales Dpt

REFERENCE STANDARD

	BSP	UN-UNF
THREAD ACCORDING TO	ISO 228/1	ISO 263
	BS 2779	ANSI B1.1 unified
CAVITY DIMENSION ACCORDING TO	ISO 1179	11926
	SAE	J11926
	DIN 3852-2 X or Y shape	

AVN020 dimensions and hydraulic circuit

Configuration without unloader valve

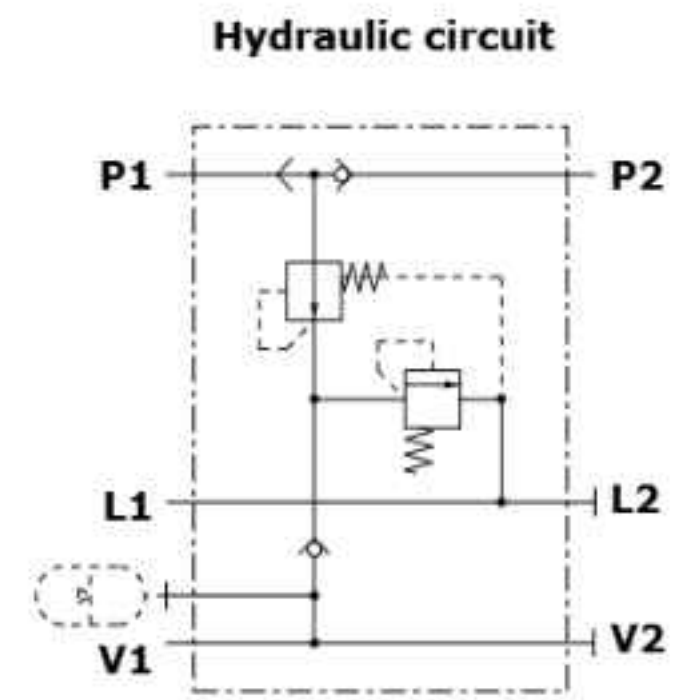
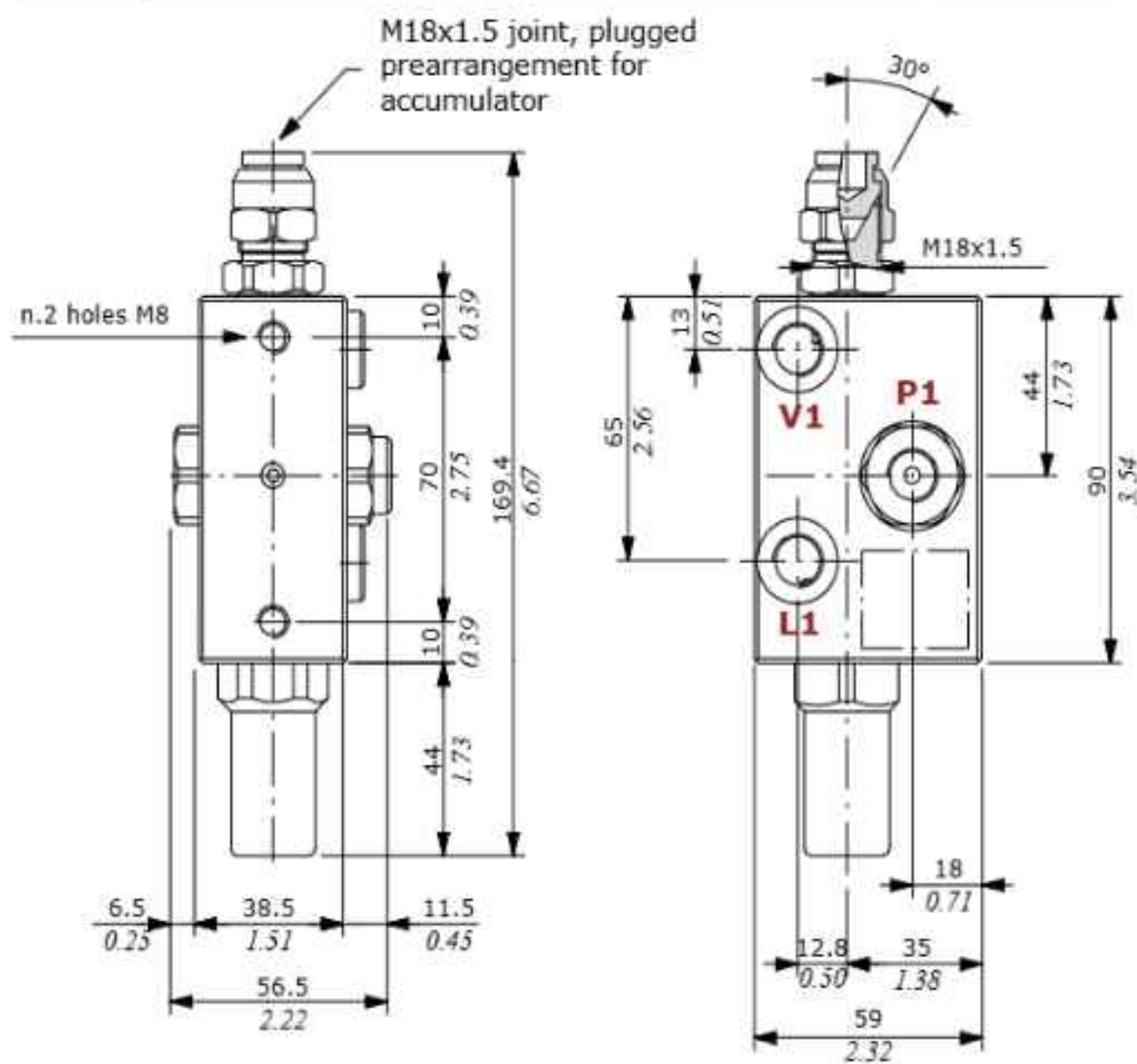

Configuration with unloader valve

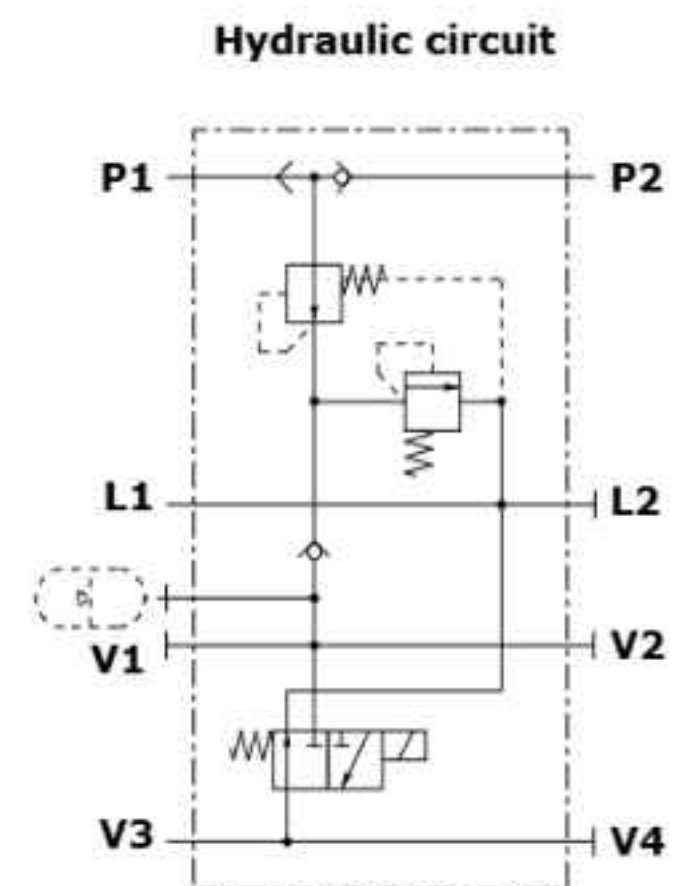
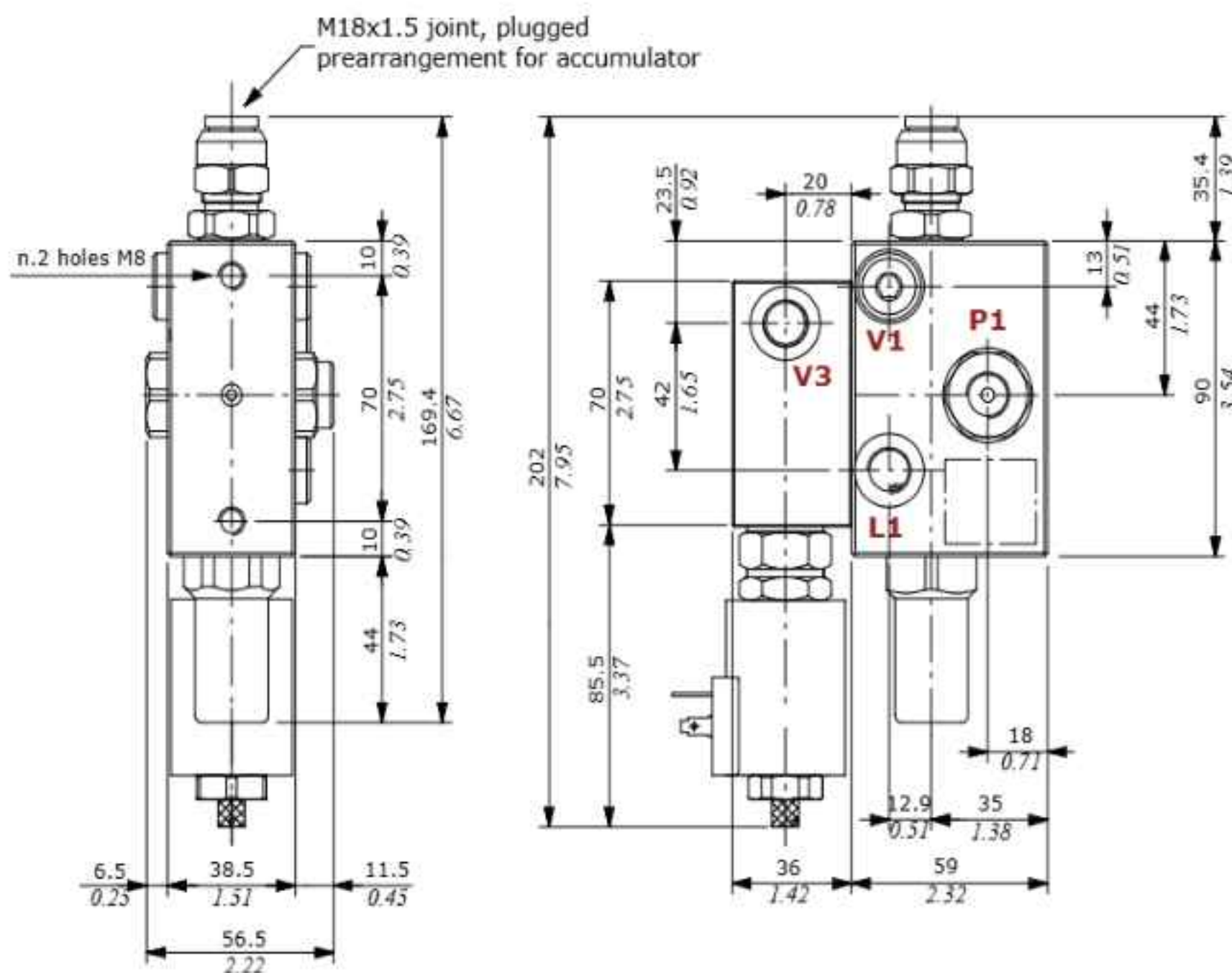

THREAD AND FITTING TIGHTENING TORQUES

Ports	Threads		Fitting tightening torque	
	BSP	UN-UNF	Nm	lbf
P1 inlet	G 1/4	9/16-18 (SAE 6)	30	22.13
L1, L2, V1, V2, V3, V4 Ports	G 1/4	9/16-18 (SAE 6)	30	22.13

AVN020 ordering codes

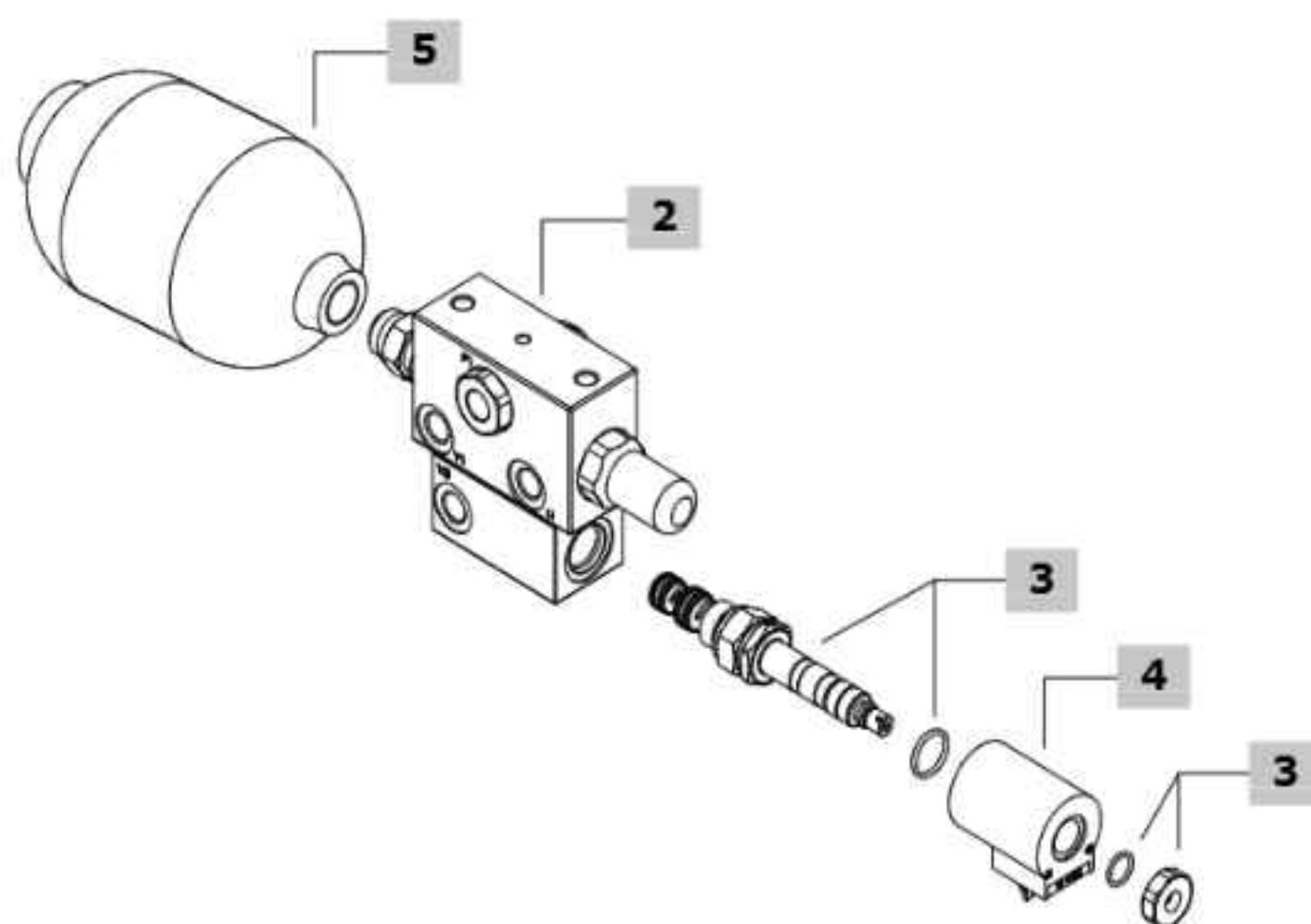
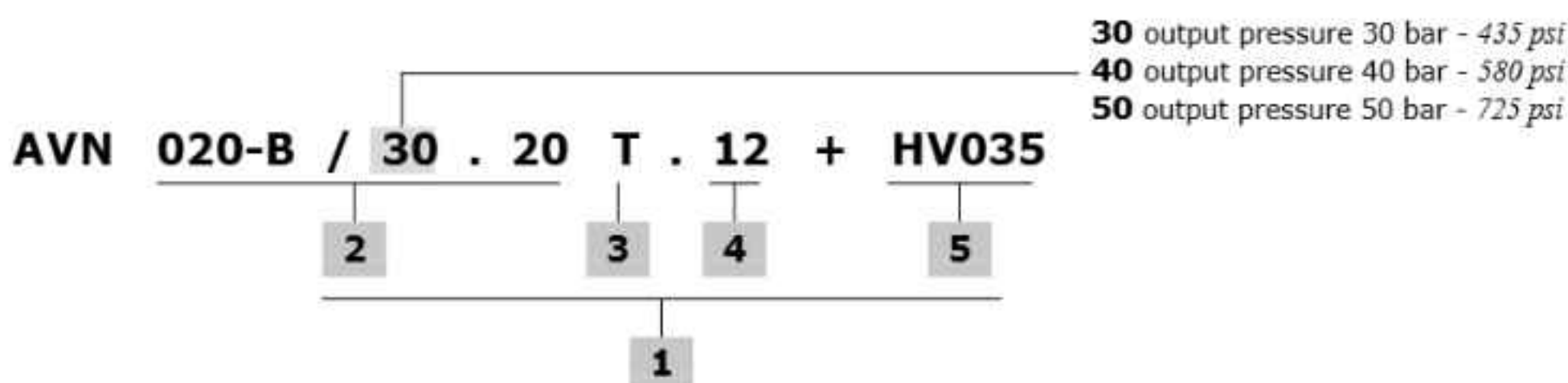

1 Complete unit *

Without unloader valve

TYPE: **AVN020-B/30.00** CODE: 180010001

DESCRIPTION: with 2 pressure ports, outlet pressure 30 bar - 435 psi

TYPE: **AVN020-B/40.00** CODE: 180010002

DESCRIPTION: with 2 pressure ports, outlet pressure 40 bar - 580 psi

TYPE: **AVN020-B/50.00** CODE: 180010003

DESCRIPTION: with 2 pressure ports, outlet pressure 50 bar - 725 psi

TYPE: **AVN020-B/30.20T.12** CODE: 180010011

DESCRIPTION: with 2 pressure ports, outlet pressure 30 bar - 435 psi, with unloader valve

2 Body kit *

TYPE	CODE	DESCRIPTION
020-B/00.20	5CO2902201	with 2 pressure ports

NOTE: outlet pressure 30, 40 and 50 bar - 435, 580, 725 psi

3 Unloader valve

TYPE	CODE	DESCRIPTION
T	0EJ08002043	With screw type emergency

4 Coil

TYPE	CODE	DESCRIPTION
12	4SL3000120	12VDC, ISO4400 connector
24	4SL3000240	As previous one 24VDC
12(JPT)	4SL3000122	12VDC, AMP/JPT connector
24(JPT)	4SL3000248	As previous one, 24VDC
12(JPT+DIODO)	4SL3001200	12VDC, AMP/JPT connector with diode
12(DT04)	4SL3000130	12VDC, DEUTSCH/DT04 connector
24(DT04)	4SL3000249	As previous one, 24VDC
12(DT04+DIODO)	4SL3000132	12VDC, DEUTSCH/DT04 connector, with diode
24(DT04+DIODO)	4SL3000247	As previous one, 24VDC

5 Optional accumulator

TYPE	CODE	DESCRIPTION
HV035	2X280020340S	Capacity 350 cm ³ - 21.36 in ³
HV050	2X280020500S	Capacity 500 cm ³ - 30.51 in ³
HV075	4AC7742000	Capacity 750 cm ³ - 45.77 in ³
HV090	2X280020700S	Capacity 900 cm ³ - 54.92 in ³
HV150	2X280021400S	Capacity 1500 cm ³ - 91.53 in ³

NOTE (*) - Codes are referred to **BSP** thread.

FU series configuration examples

Type FU/1 - one stage

CODE: 1992752200

TYPE: FU-AC(SAE6-11)-RB08A(35)-F-NV/1EJ08F4(L=170)/NPM-SAE6(AT)12(PP1)-12VDC

DESCRIPTION: one stage, with pressure reducing valve on inlet, 0.35 l accumulator and 1 directional solenoid valve for the supply and control of the pressure line.

Hydraulic circuit

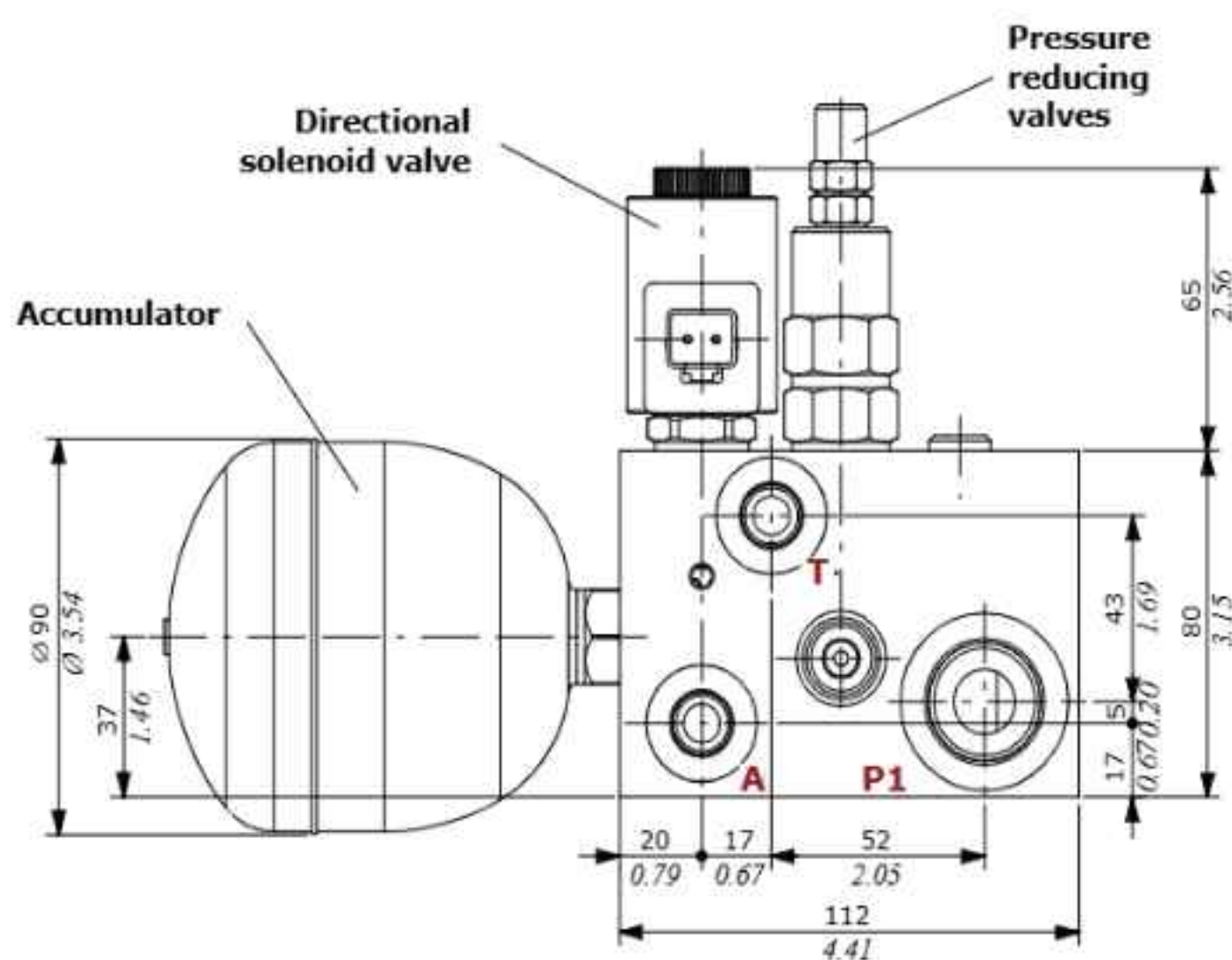
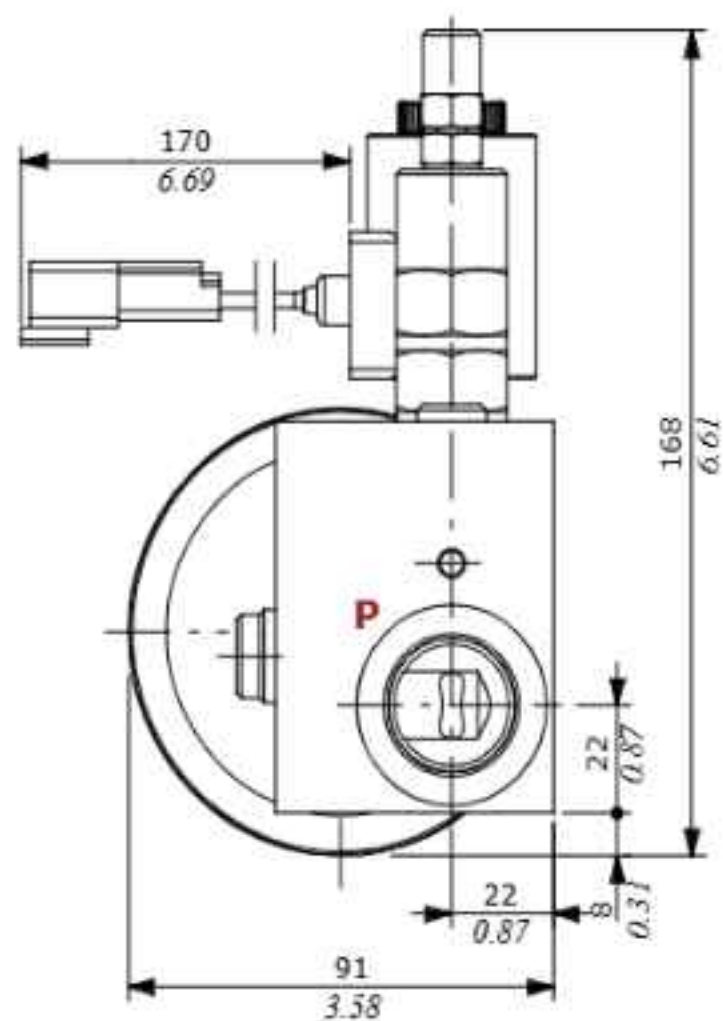
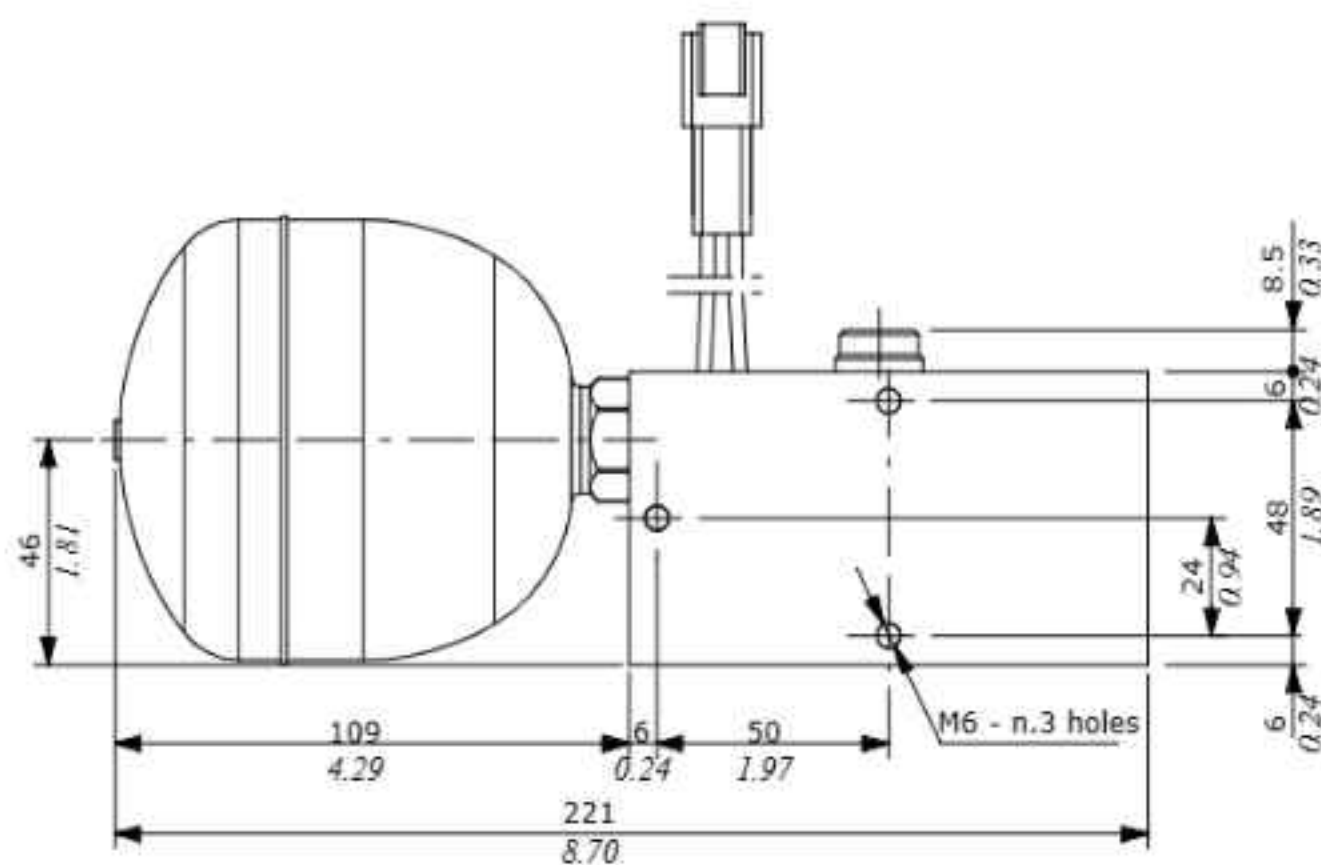
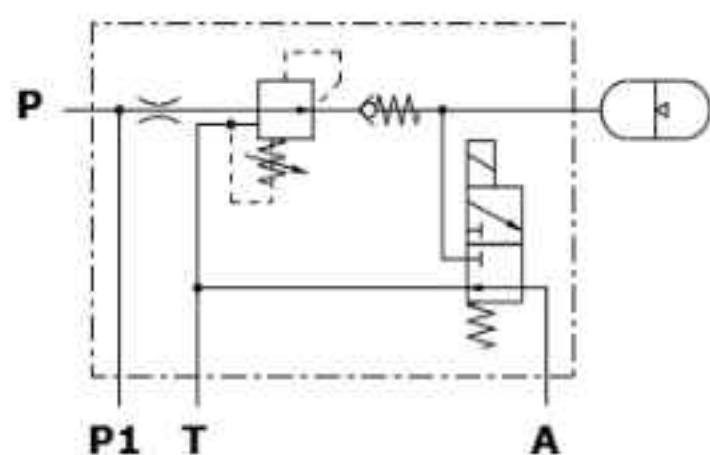

PORTS THREADING AND FITTINGS TIGHTENING TORQUE

PORTS	Threads (different threads on request)	Fitting tightening torque	
		Nm	lbft
P, P1 inlet	1 1/16-12 UN (SAE 12)	65	48
A port	9/16-18 UNF (SAE 6)	30	22
T outlet	9/16-18 UNF (SAE 6)	30	22
Accumulator connection	9/16-18 UNF (SAE 6)	30	22

NOTE - These torques are recommended. Assembly tightening torque depends on many factors, including lubrication, coating and surface finishing. The fittings manufacturer has to be consulted.

FU series configuration examples

Type FU/2 - two stages

CODE: 1992820001

TYPE: FU-AC(SAE6-11)-RB08A(35)-F-NV/2RPT2/PMA-P1-L-V-BSP-24VDC-<TAP(P1LV)>

DESCRIPTION: two stages, with pressure reducing valve on inlet, 0.35 l accumulator and 2 proportional pressure reducing valves for the supply and control of the pressure lines.

Hydraulic circuit

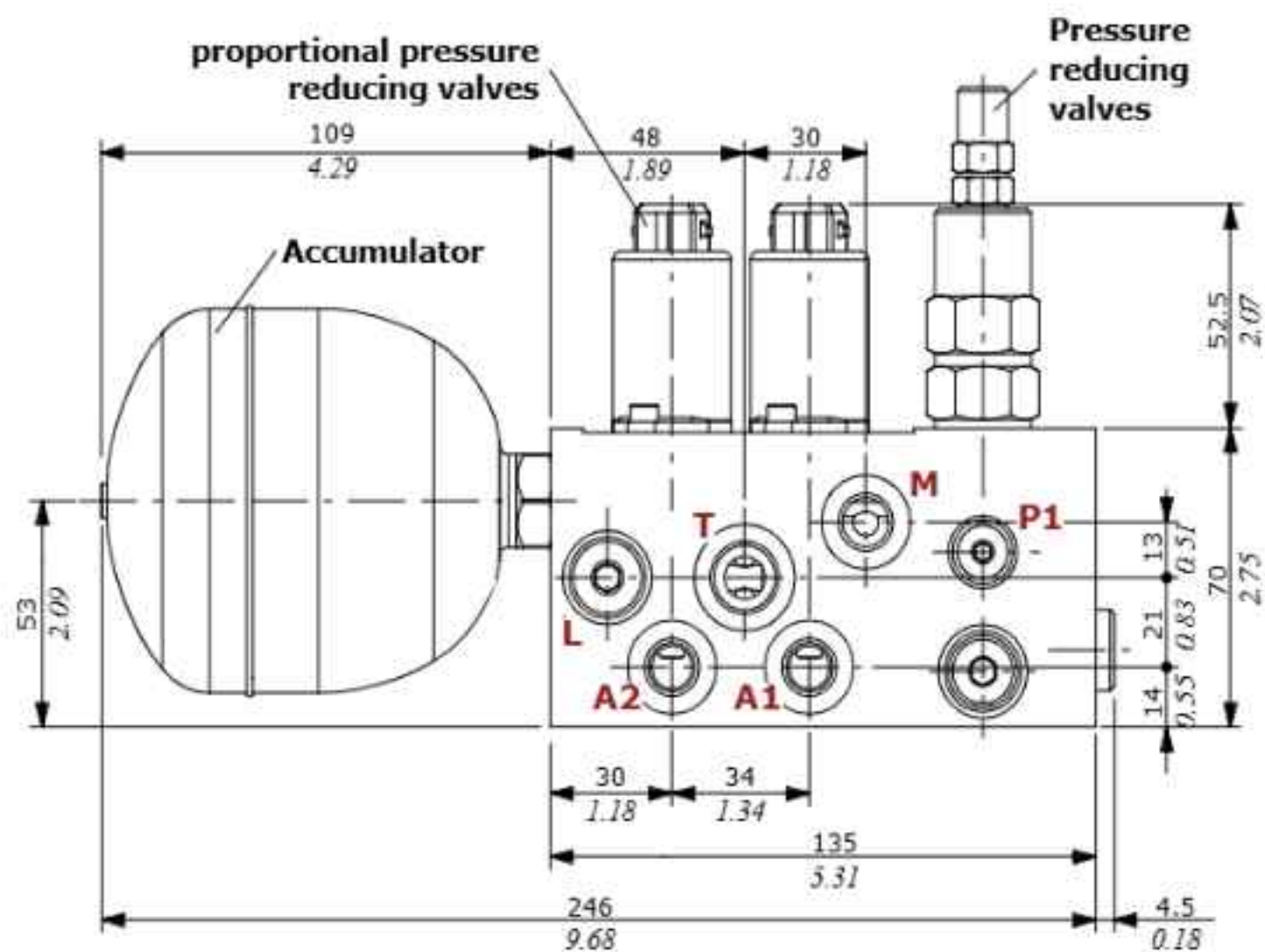
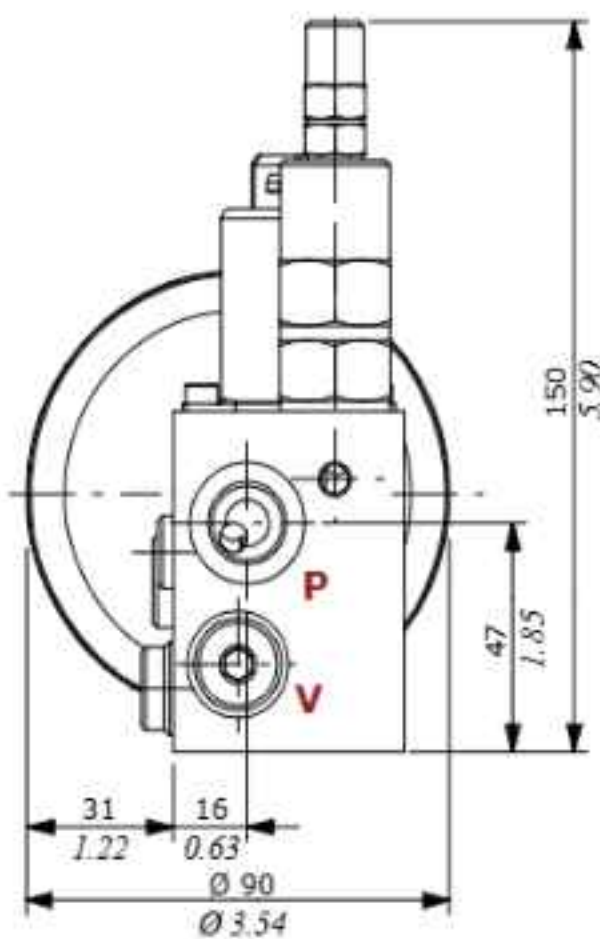
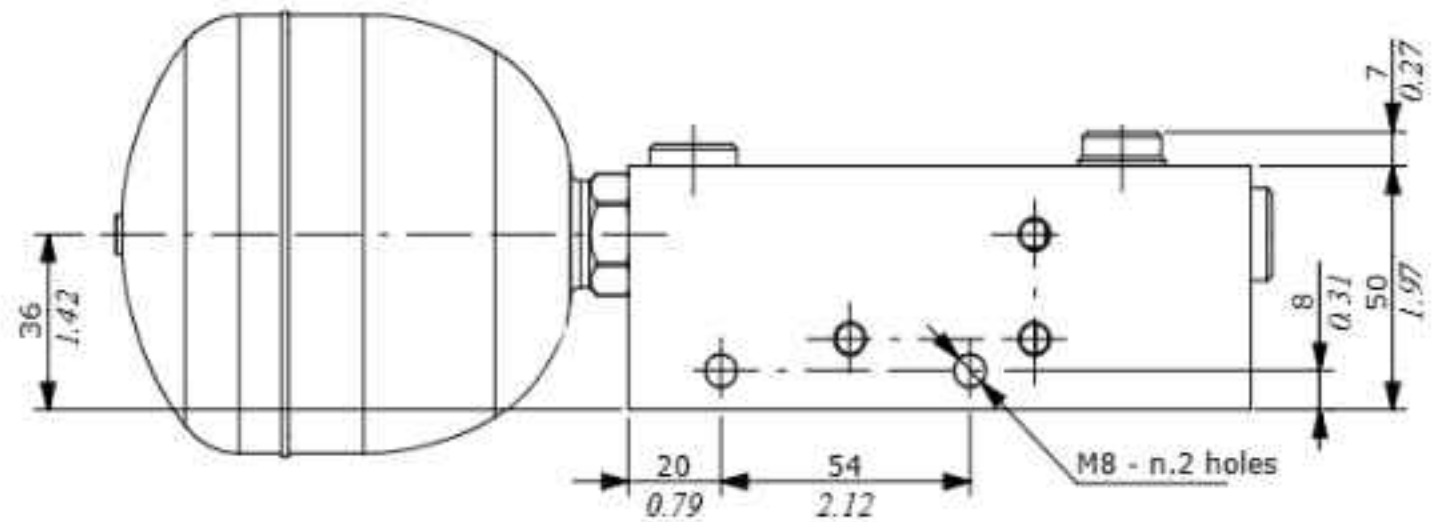
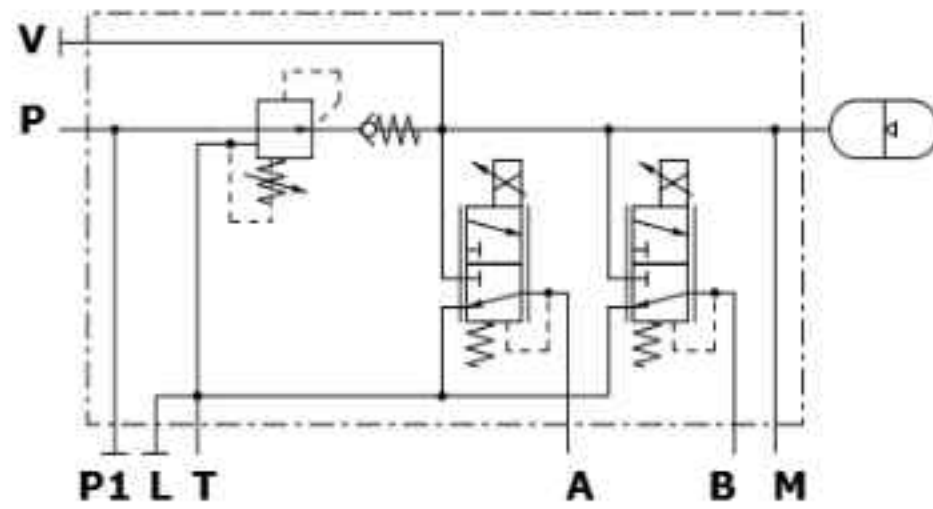

PORTS THREADING AND FITTINGS TIGHTENING TORQUE

PORTS	Threads (different threads on request)	Fitting tightening torque	
		Nm	lbft
P Inlet	BSP G 3/8	42	31
P1 Inlet	BSP G 1/8	24	17.7
A, B, M, L, V Ports	BSP G 1/4	30	22
Outlet T	BSP G 3/8	42	31
Accumulator connection	9/16-18 UNF (SAE 6)	30	22

NOTE - These torques are recommended. Assembly tightening torque depends on many factors, including lubrication, coating and surface finishing. The fittings manufacturer has to be consulted.

FU series configuration examples

Type FU/3 - three stages

CODE: 1992830000

TYPE: FU-AC(SAE6-11)-NR-A-VMP5JN(TB.S-35)/3-EJ08F/PMI-P2-BSP-12VDC

DESCRIPTION: three stages, with pressure relief valve on inlet, 0.35 l accumulator and 3 directional solenoid valves for the supply and control of the pressure lines.

Hydraulic circuit

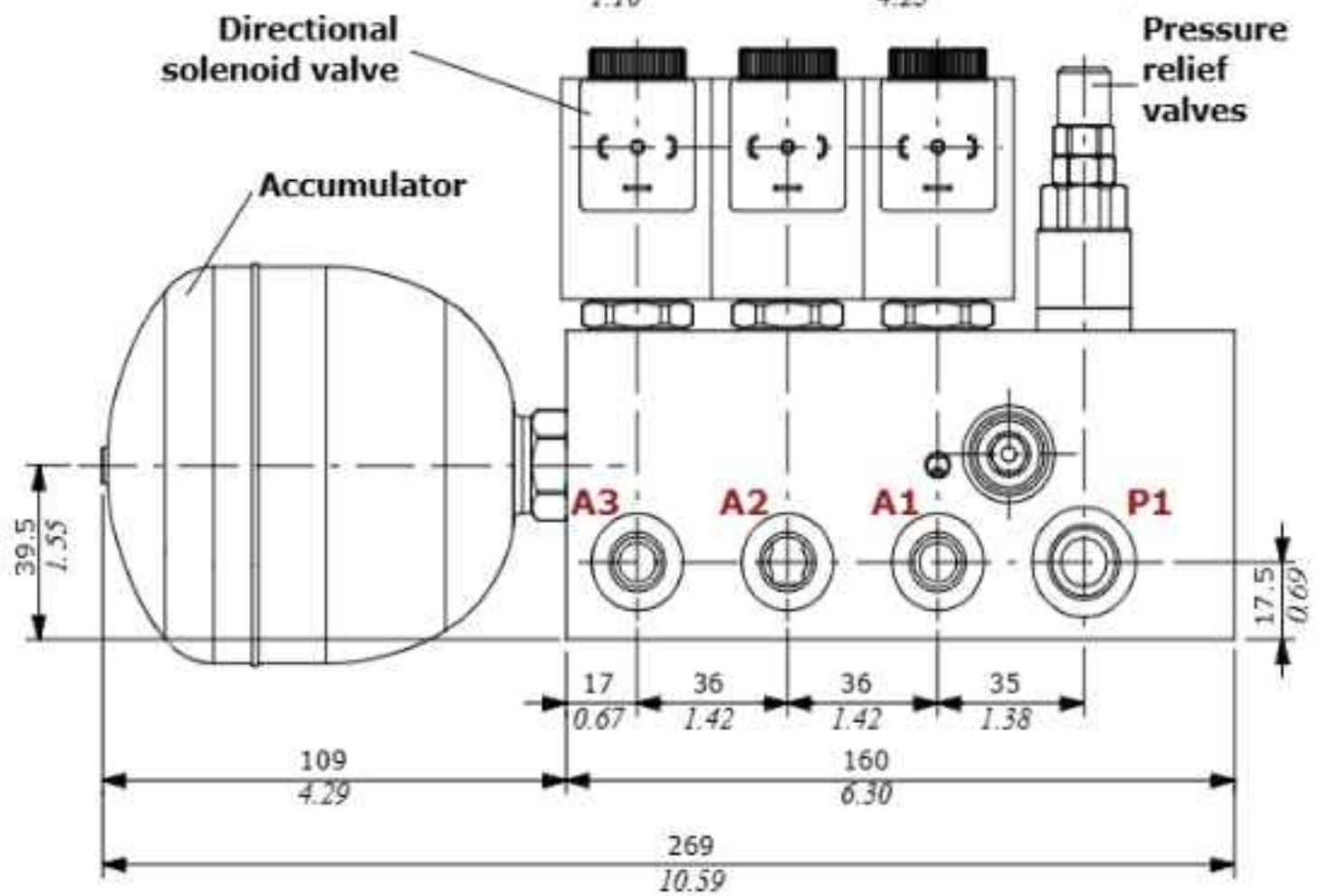
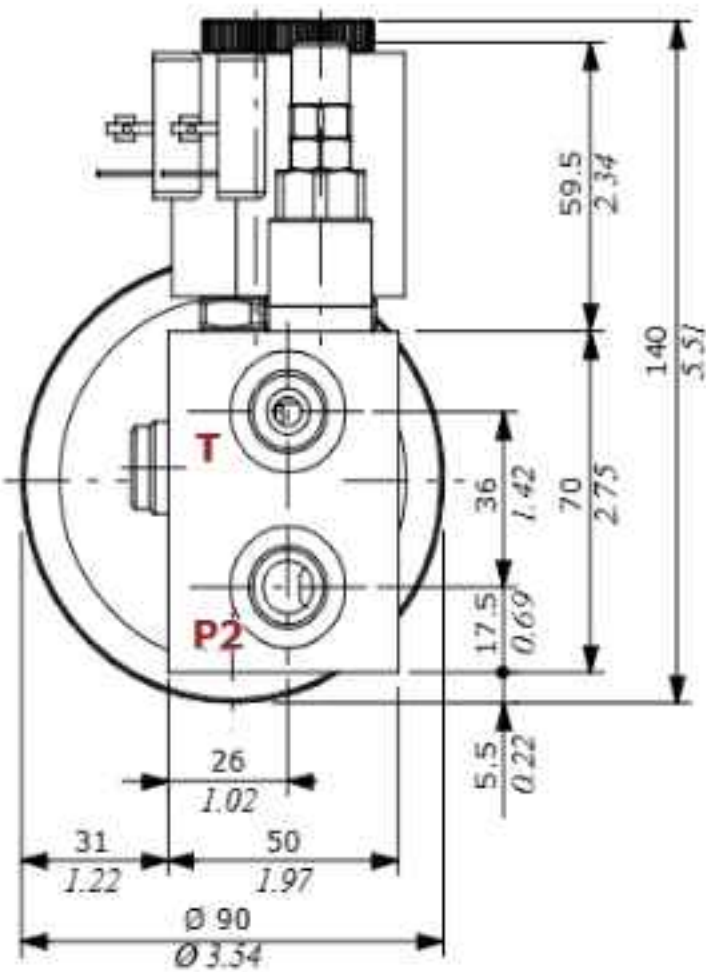
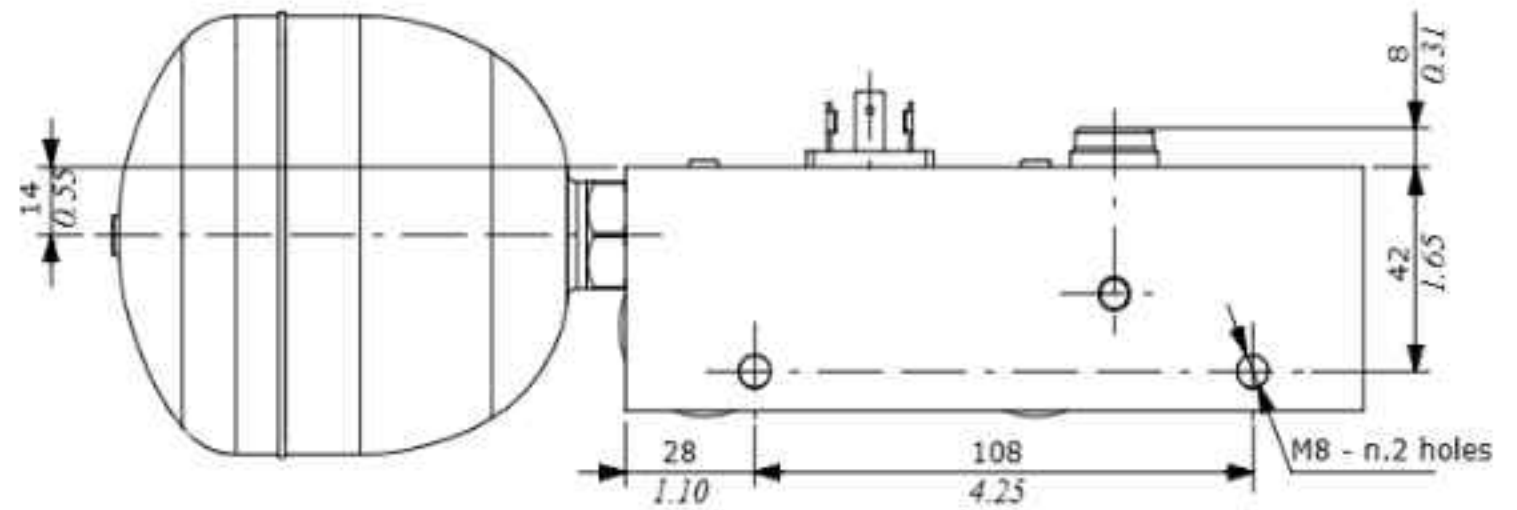
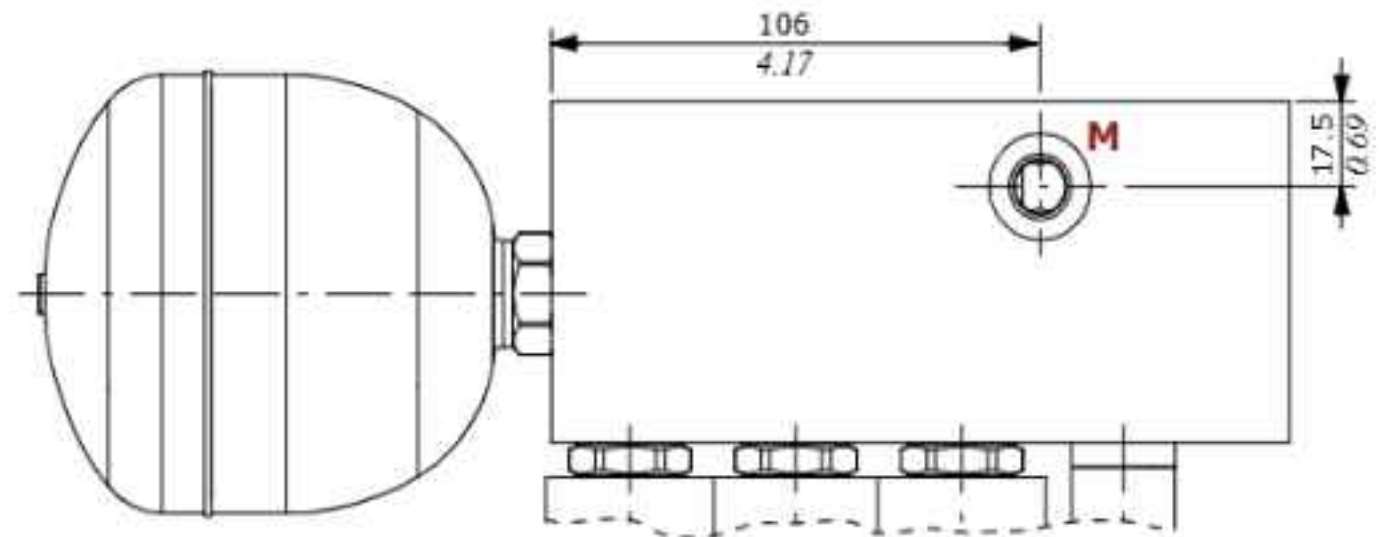
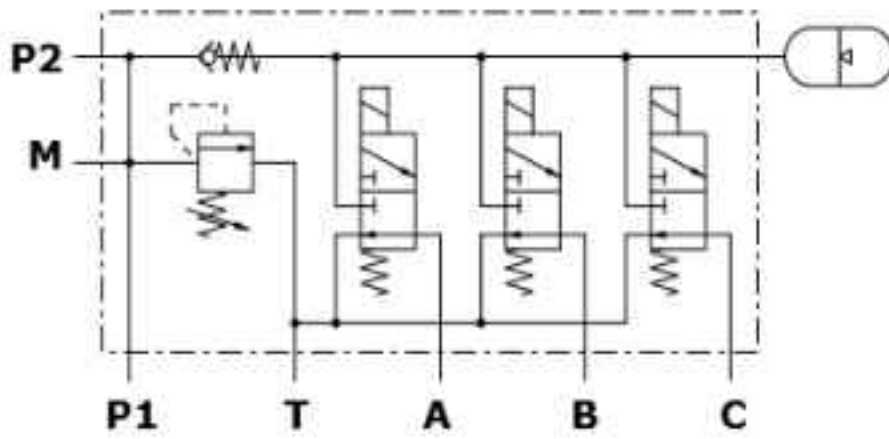

PORTS THREADING AND FITTINGS TIGHTENING TORQUE

PORTS	Threads (different threads on request)	Fitting tightening torque	
		Nm	lbft
P inlet	BSP G 3/8	42	31
P1 inlet	BSP G 3/8	42	31
A, B, M, L, V ports	BSP G 1/4	30	22
T outlet	BSP G 3/8	42	31
Accumulator connection	9/16-18 UNF (SAE 6)	30	22

NOTE - These torques are recommended. Assembly tightening torque depends on many factors, including lubrication, coating and surface finishing. The fittings manufacturer has to be consulted.

FU series configuration examples

Type FU/4 - four stages

CODE: 1992840000

TYPE: FU-AC(SAE6-11)-RB08A(35)-F-NV/4RPT2/PMA-P1-L-V-BSP-24VDC-<TAP(P1LV)>

DESCRIPTION: four stages, with pressure reducing valve on inlet, 0.35 l accumulator and 4 proportional pressure reducing valves for the supply and control of the pressure lines.

Hydraulic circuit

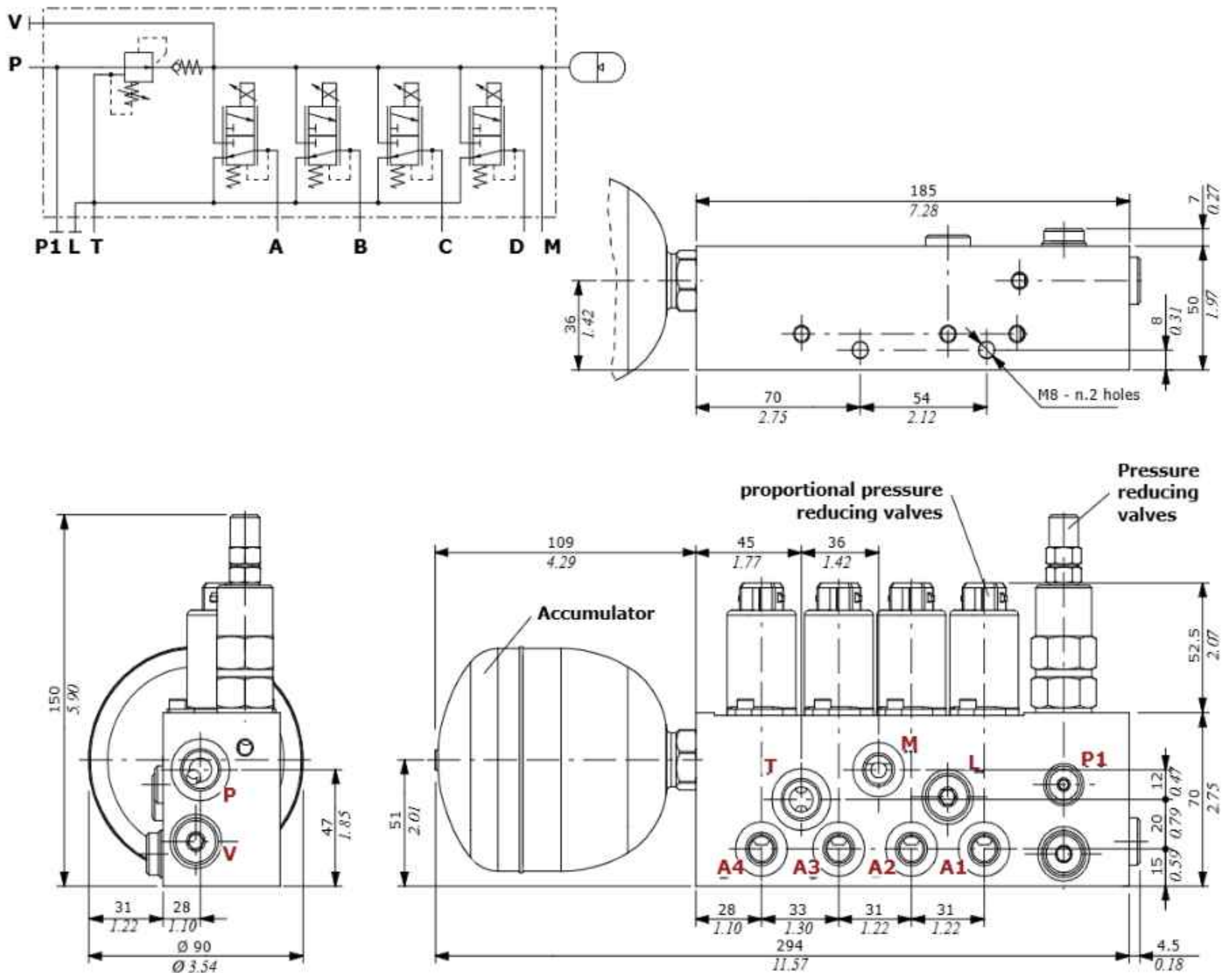

PORTS THREADINGS AND FITTING TIGHTENING TORQUE

PORTS	Threads (different threads on request)	Fitting tightening torque	
		Nm	lbft
P inlet	BSP G 3/8	42	31
P1 inlet	BSP G 1/8	24	17.7
A, B, C, D, M, L, V ports	BSP G 1/4	30	22
T outlet	BSP G 3/8	42	31
Accumulator connection	9/16-18 UNF (SAE 6)	30	22

NOTE - These torques are recommended. Assembly tightening torque depends on many factors, including lubrication, coating and surface finishing. The fittings manufacturer has to be consulted.

DHV080 diverter valve

Pressure drop

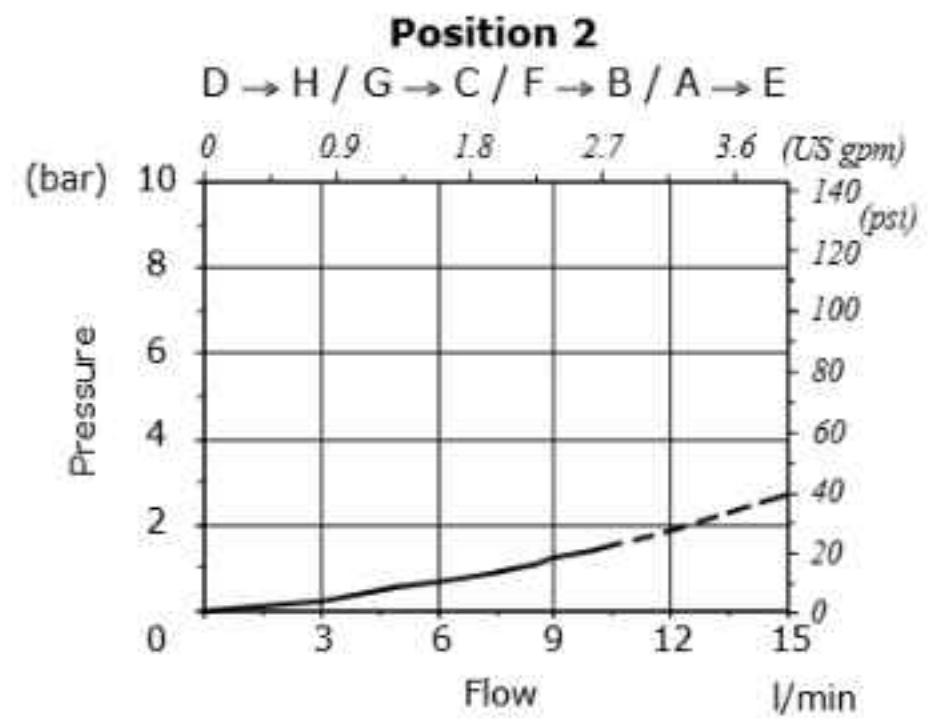
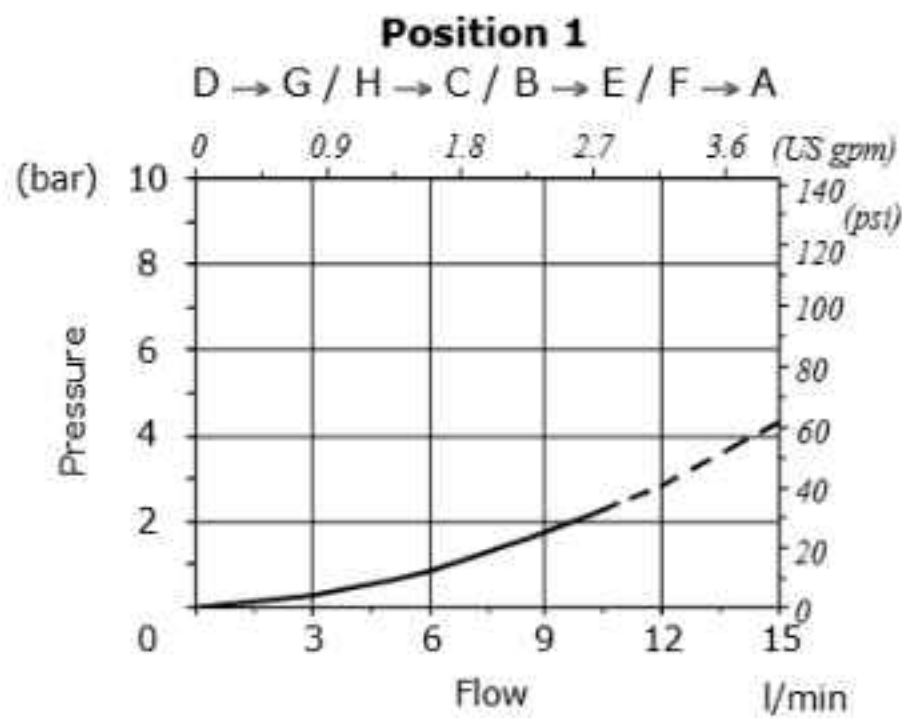

Dimensions and hydraulic circuit

The diverter valve is available in this configuration: **DHV080/8LN-BSP-<CVN>** code **140080000**

Supplied as standard, with one coat of primer black antirust.

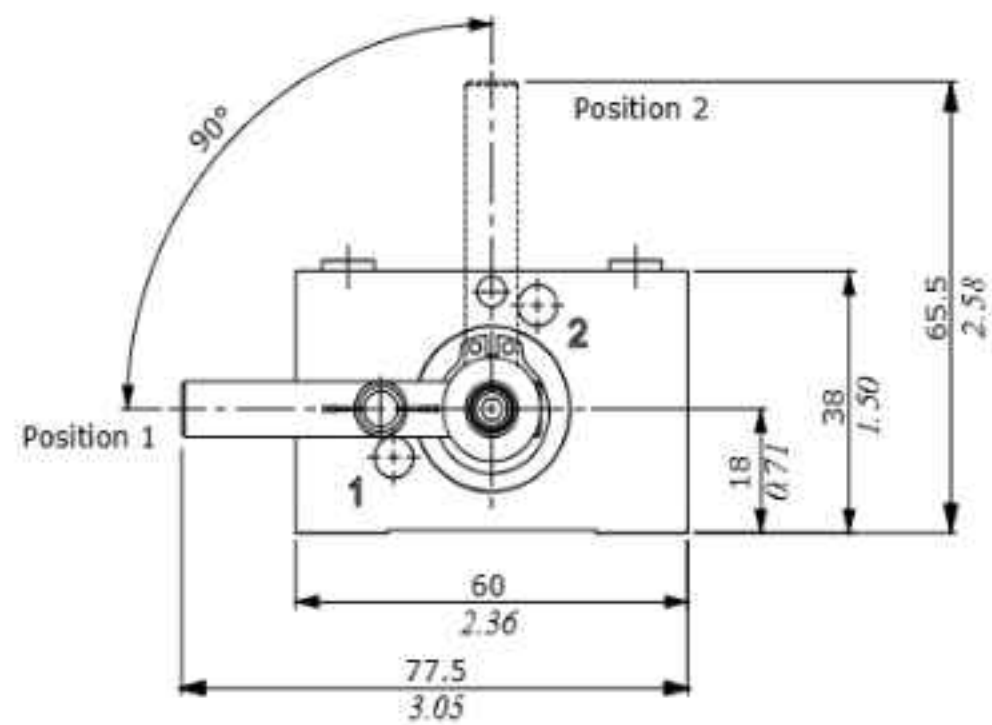
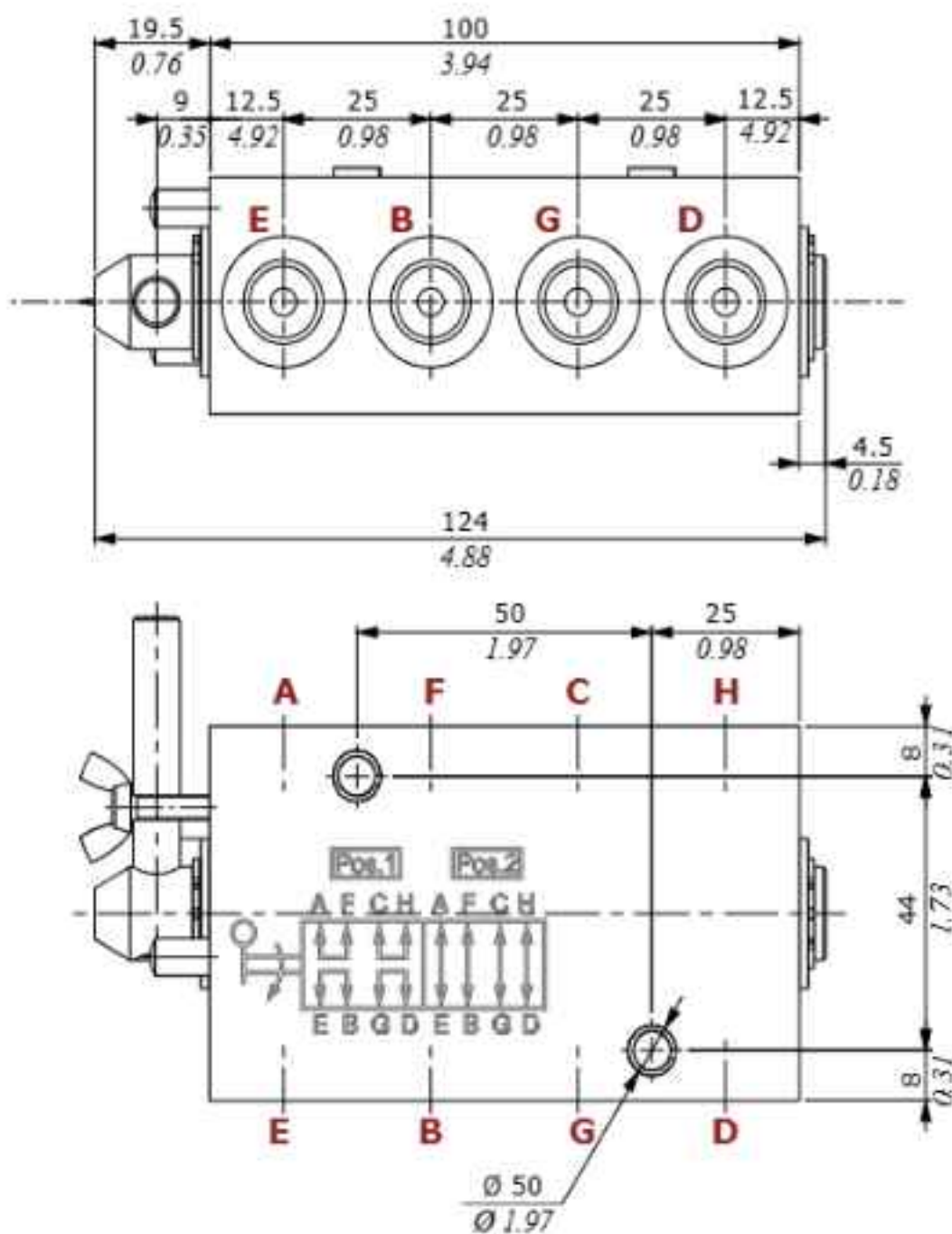

Hydraulic circuit

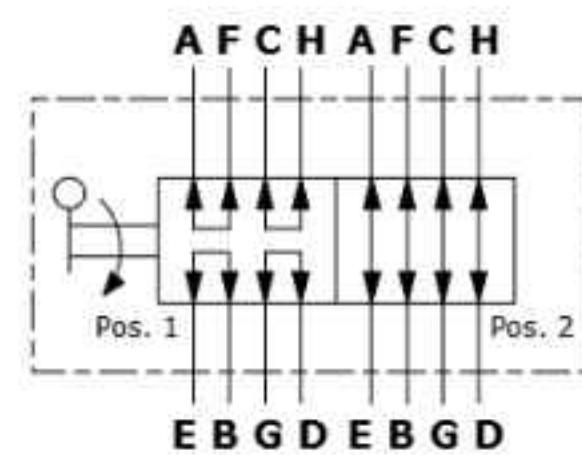

PORT THREADING AND FITTING TIGHTENING TORQUE

PORTS	Threads		Fitting tightening torque	
	BSP	UN-UNF	Nm	lbft
A, B, C, D, E, F, G, H ports	G 1/4	7/16-20 UNF-2B (SAE4)	30	22

NOTE - These torque are recommended. Assembly tightening torque depends on many factors, including lubrication, coating and surface finish. The manufacturer shall be consulted.

DHV080 diverter valve

Typical application

Joystick movement

SVM pilot control valve

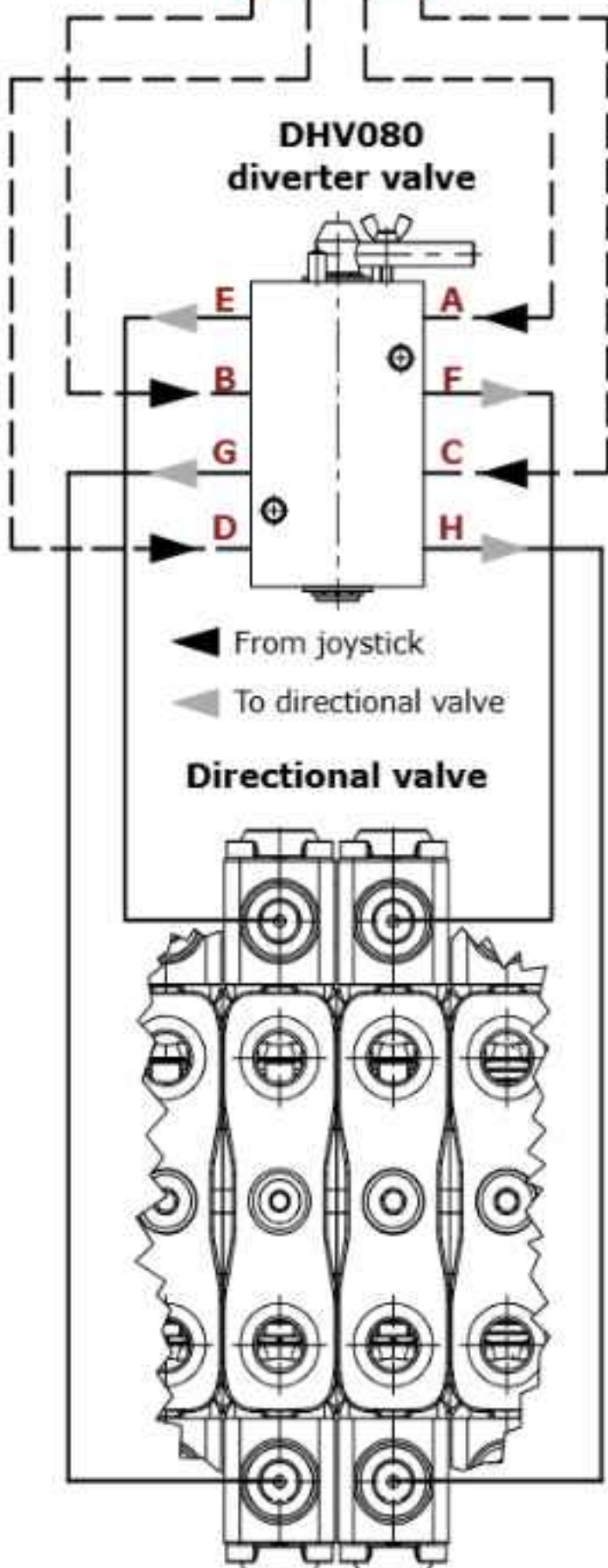
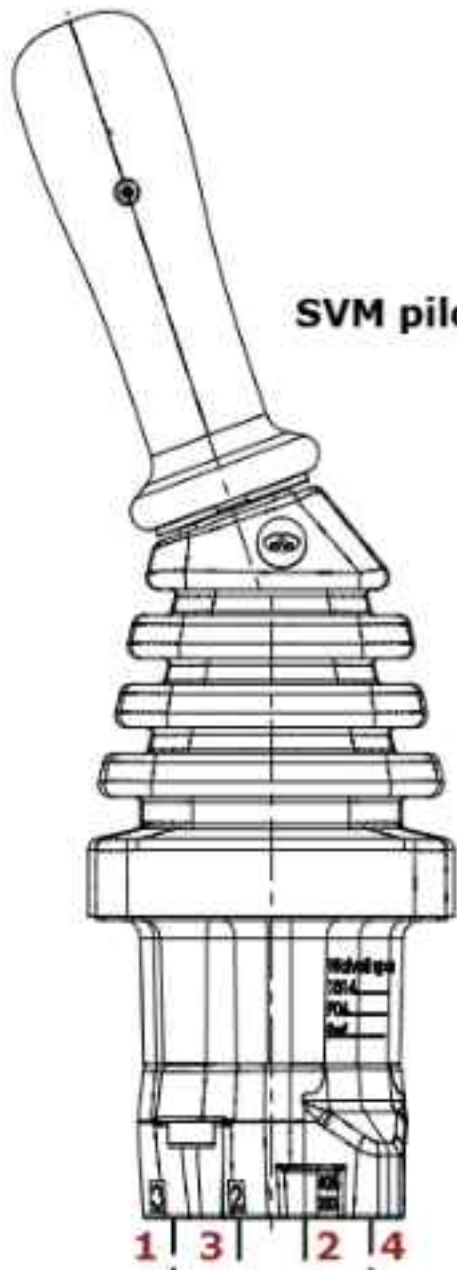

Diverter valve in position 1
Backhoe configuration

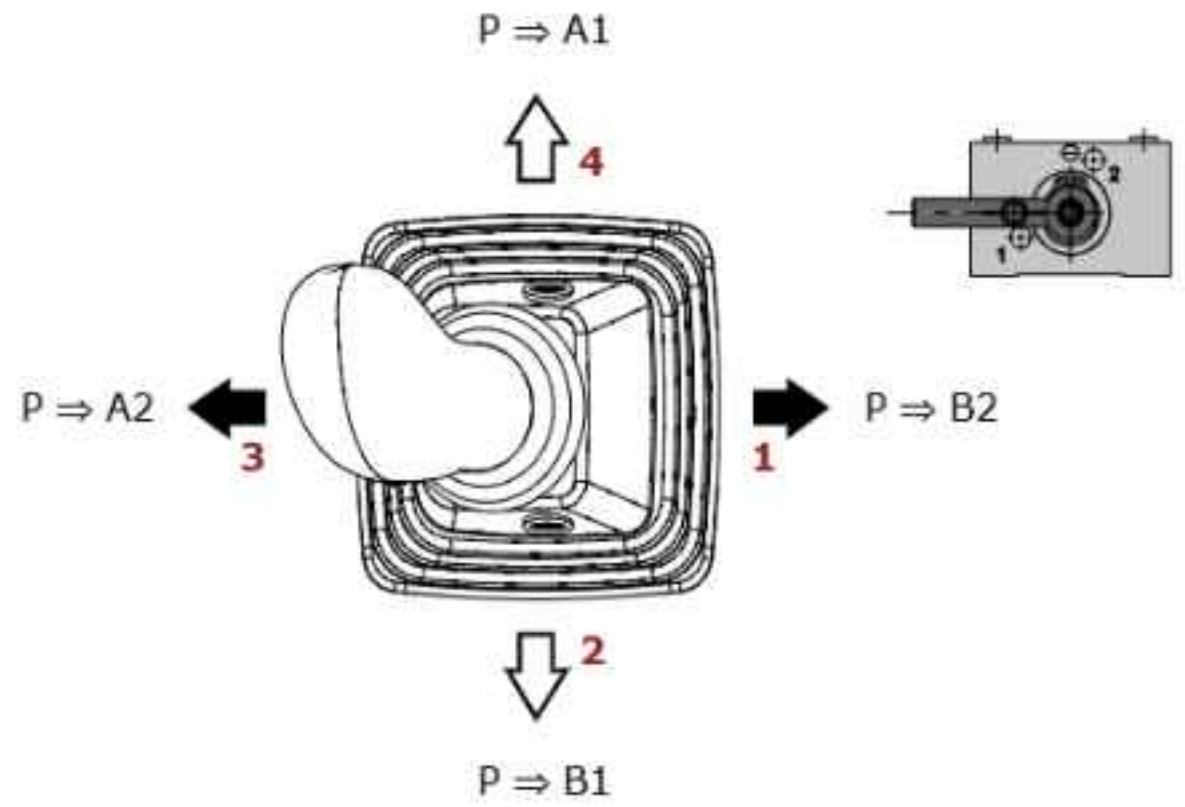

Diverter valve in position 2
Mini-excavator configuration

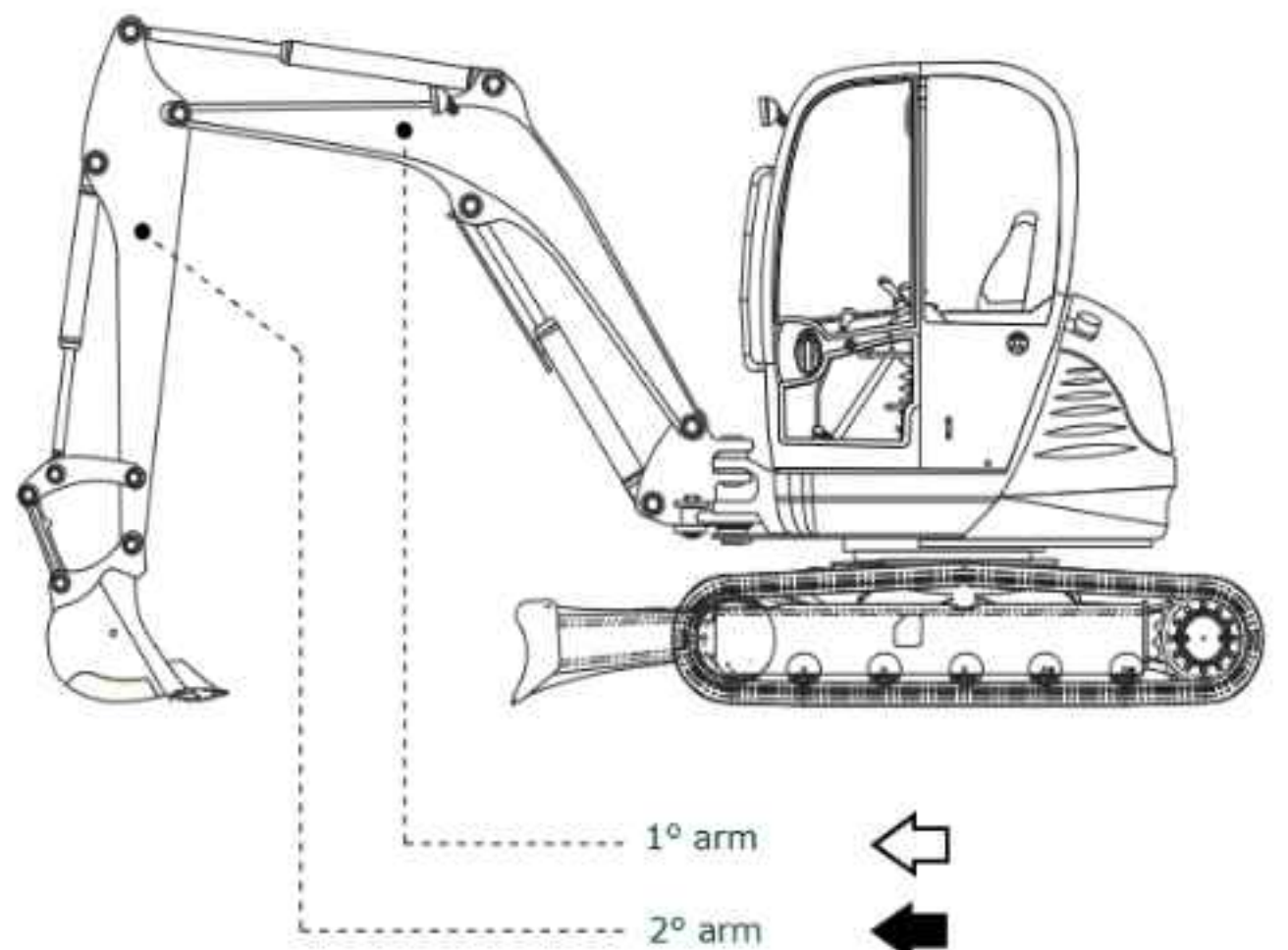
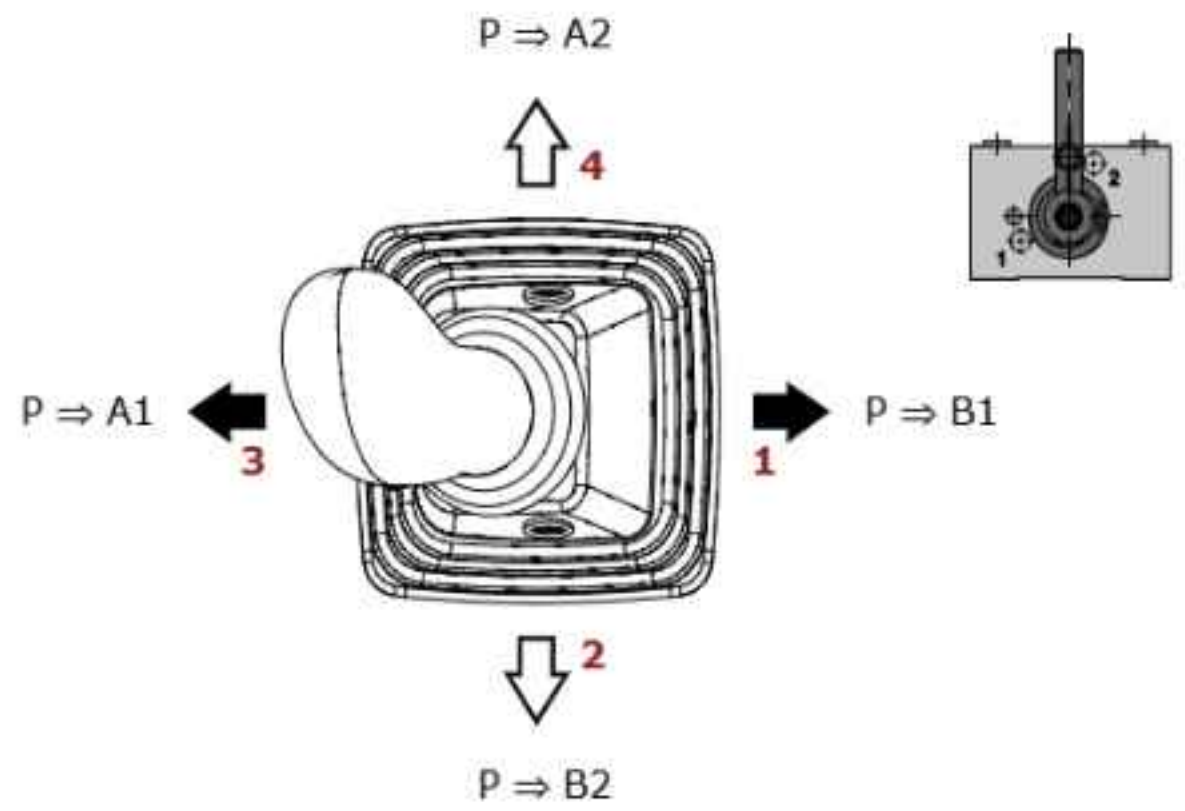

Appendix

Suggested pressure control curves for hydraulic controls

Below the suggested pressure control curves for hydraulic control operating on the directional control valves.
The list is indicative; for more informations or different curves, please refer to the SVM chapters or ask to our Sales Department.

For monoblock directional control valves

Hydraulic controls Type	Code*	SD5 SDM110	SDM100	SDM140 DLM140	SDM141	SD11	SD14	SD18
8IM	5IDR205021	00026						
	5IDR207300		00088					
	5IDR208300			00033	00033			
	5IDR210000					00070	00070	
	5IDR220000							00070
13IM	5IDR205330	00075 (VA) E0094 (VB)						
	5IDR208214			00075 (VA) E0094 (VB)	00075 (VA) E0094 (VB)			
13IMS	5IDR207350		00053 (VA) E0075 (VB)					
13DM	5IDR208314			00075 (VA) E0075 (VB)	00075 (VA) E0075 (VB)			

For sectional directional control valves

Hydraulic controls Type	Code*	SD6	DLS7	SDS100	SD8 SDS140	DLS8	SDS150	SDS180	DLS180	SD25	SDS400
8IM	5IDR206010	00075									
	5IDR207300			00088							
	5IDR208300				00033						
	5IDR216300						00033	00033			
	5IDR225300									00053	
	5IDR208300										00028
8IMS	5IDR207320			00088							
8IMO	5IDR208100				00033						
	5IDR225000									00033	
8IMOH	5IDR216300-H						00033	00033			
8IMF3	5IDR207000		00033								
	5IDR207310			00088							
	5IDR208220					00021					
	5IDR216303							00033	00033		
13IM	5IDR208310									00010 (VA) E0096 (VB)	
13IMS	5IDR207350		00053 (VA) E0075 (VB)								
13IMO	5IDR225350								00075 (VA) E0075 (VB)		
13IMPOH	5IDR216014-H						00075 (VA) E0075 (VB)				

Note (*): Codes are referred to controls with BSP threading

Suggested pressure control curves for hydraulic controls

For Load Sensing and Flow Sharing directional control valves

Hydraulic controls Type	Code*	DPC130	DPC200	DPX050	DPX100	DPX160
8IM	5V08130800	00020				
	5V08200801		00020			
	5IDR20A300V			00089		
8IMN	5IDR204304V				00089	
8IMNO	5IDR204305V				00089	
8IMX	5IDR20A301V			00028		
8IMXN	5IDR204303V				00054	
8IMOHN	5IDR209304V-H					00089
8IMF3	5IDR20A302V			00089		
8IMF3N	5IDR204314V				00089	
8IMXF3	5IDR20A303V			00028		
8IMXF3N	5IDR204313V				00054	
8IMOHF3N	5IDR209305V-H					00089
13IMP	5IDR20A310V			00089 (VA)-E0086 (VB)		
13IMS	5IDR207350V				00053 (VA)-E0075 (VB) 01098 (VA)-E0086 (VB)	
13IMOH	5IDR209303V-H					00089 (VA)-E0033 (VB)
13IMPOH	5IDR209014V					00073 (VA)-E0073 (VB)

Note (*): Codes are referred to controls with BSP threading

Installation notes

SVM pilot control valves assembled and tested as per the technical specification of this catalogue.

Before the final installation on your equipment, follow the below recommendations:

- the pilot valves must be assembled in horizontal position: considering the mass of the kinematic and control kit, a max. angle of 20° is allowed;
- the feeding unit can be assembled in any position; keep it away from heat sources when it is equipped with accumulator;
- fix the devices with suitable screw, use the appropriate flange or drilling, after tightening check the seal and the safety of the assembly;
- verify the integrity of the contact between devices and fittings and eliminate any impurities;
- correctly connect the devices, do not reverse the P and T ports (see dimensional pages to determine the initials of the ports);
- in order to prevent the possibility of water entering the rubber bellow, do not use high pressure wash directly on the valve;
- prior to painting, ensure plastic port plugs are tightly in place;
- the electrical cables have not to be submitted to mechanical forces (ex. tension or torsion);
- use original handles and handlevers.



Innovation · Continuity · Integration
————— It is Power —————

 **walvoil**
FLUID POWER SOLUTION

 **walvoil**

 **hydro
control**

 **Galtech**

D1WWEF01E
5th edition November 2021

Walvoil S.P.A. • 42124 Reggio Emilia • Italy • Via Adige, 13/D • Tel. +39.0522.932411 • Fax +39.0522.300984
www.walvoil.com

