



RADIAL PISTON PUMPS

Model : 11RC****

Ref. No. D 09206
Release 12 / 2025

ENGINEERING - 1 of 3

A Polyhydron Group Company

Description

Model **11RC****** are rugged Radial piston pumps and have either 5, 7 or 9 pumping elements. These pumps are valve controlled and therefore there is no restriction on direction of rotation of the pump. These pumps can be submerged in oil or externally mounted above oil level.

They are available with 9 displacements and 3 pressure ratings. The pumps give fixed output per revolution of the shaft.

Pumps with model code **11RCE***** have extension shaft for through drive and are available with extension bracket assembly for coupling a pump having standard flange as per ISO 3019/2.(Ref. datasheet no. D 09090).



Section

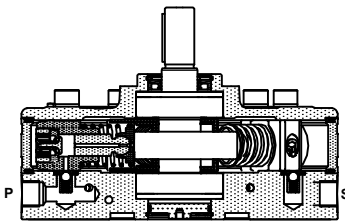

Model : 11RC***

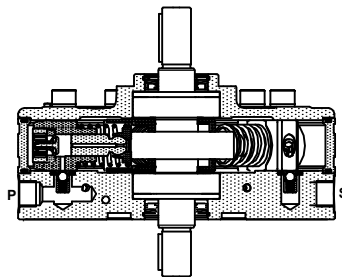

Model : 11RCE***

Hydraulic symbol

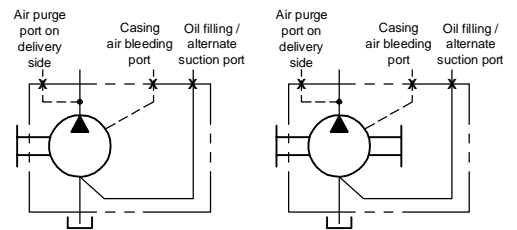

Model : 11RC***

Model : 11RCE***

Technical specifications

Designation	:	11RC is a basic radial piston pump with casing. 11RCE is a Radial piston pump with casing and extension shaft.						
Design	:	Radial piston, valve controlled.						
No. of Pumping elements	:	5, 7 or 9.						
Mounting interface	:	Factory standard, Face mounting with Air purge port at highest level. Suction Foot Valve recommended refer data sheet no. D 12400.						
Direction of rotation	:	11RC	- No restriction on direction of rotation.					
	:	11RCE	- Depends upon the direction rotation of pump attached.					
Connection	:	Suction port (S)	- G3/4 female.					
	:	Delivery (P)	- G1/2 female.					
Speed range	:	300 to 2000 r/min.						
Max. Suction Head	:	At no time allow the oil level in the tank to fall 500 mm below the axis of the pump, when the pump is mounted horizontally, or 500 mm below the mounting face of the pump, when the pump is mounted vertically.						
Flow and Pressure	:	Refer Table no. 1						
Torque limitations	:	Input drive shaft	- 220 Nm					
	:	Extension shaft	- 130 Nm					
Hydraulic medium	:	Mineral oil.						
Temperature range	:	-20°C to + 80°C.						
Viscosity range	:	10 cSt to 100 cSt.						
Fluid cleanliness required	:	ISO 4406 20/18/15 or better.						
Mass	:	Model :	11RC5	11RCE5	11RC7	11RCE7	11RC9	11RCE9
	:	Kg :	25.7	26.5	27	27.6	27.7	28.4



Unit dimensions

Dimensions in mm.

Pump without extension shaft
Model - 11RC5*, 11RC7* and 11RC9*

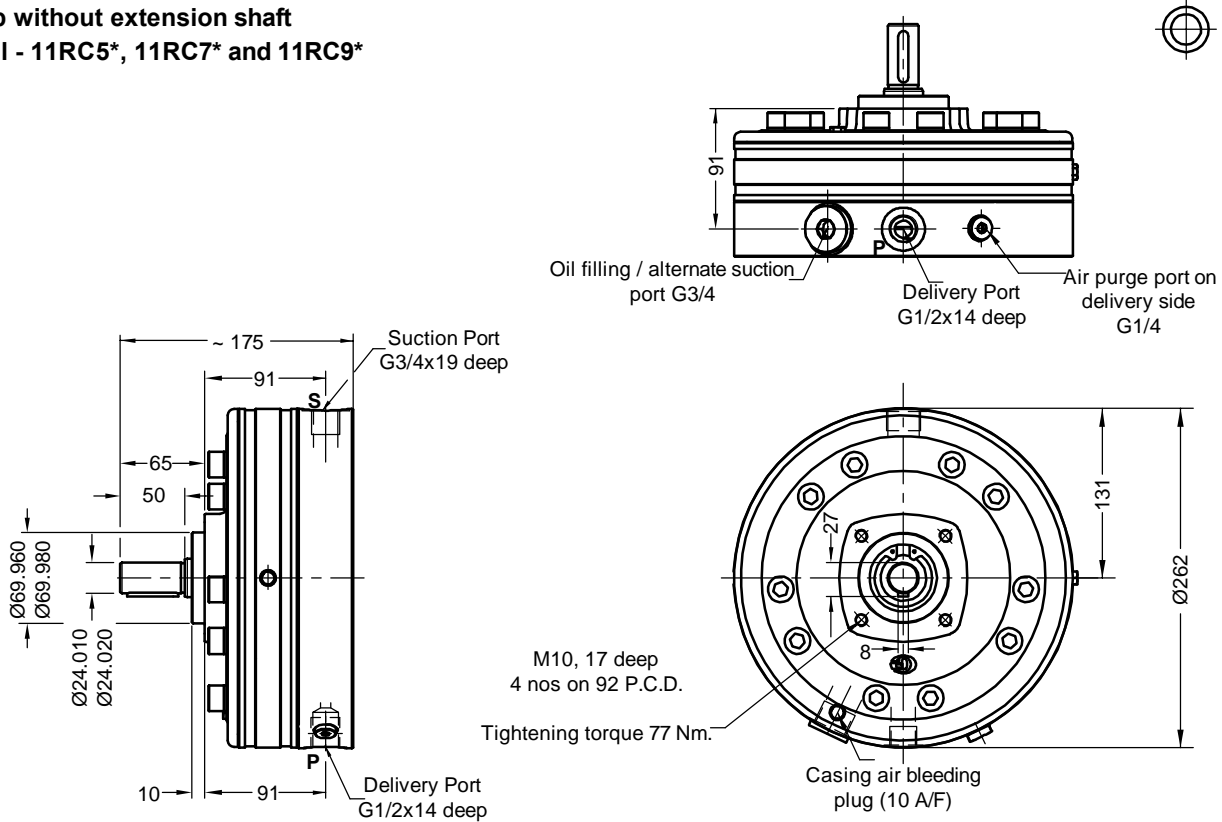

Pump with extension shaft
Model - 11RCE5* and 11RCE7*

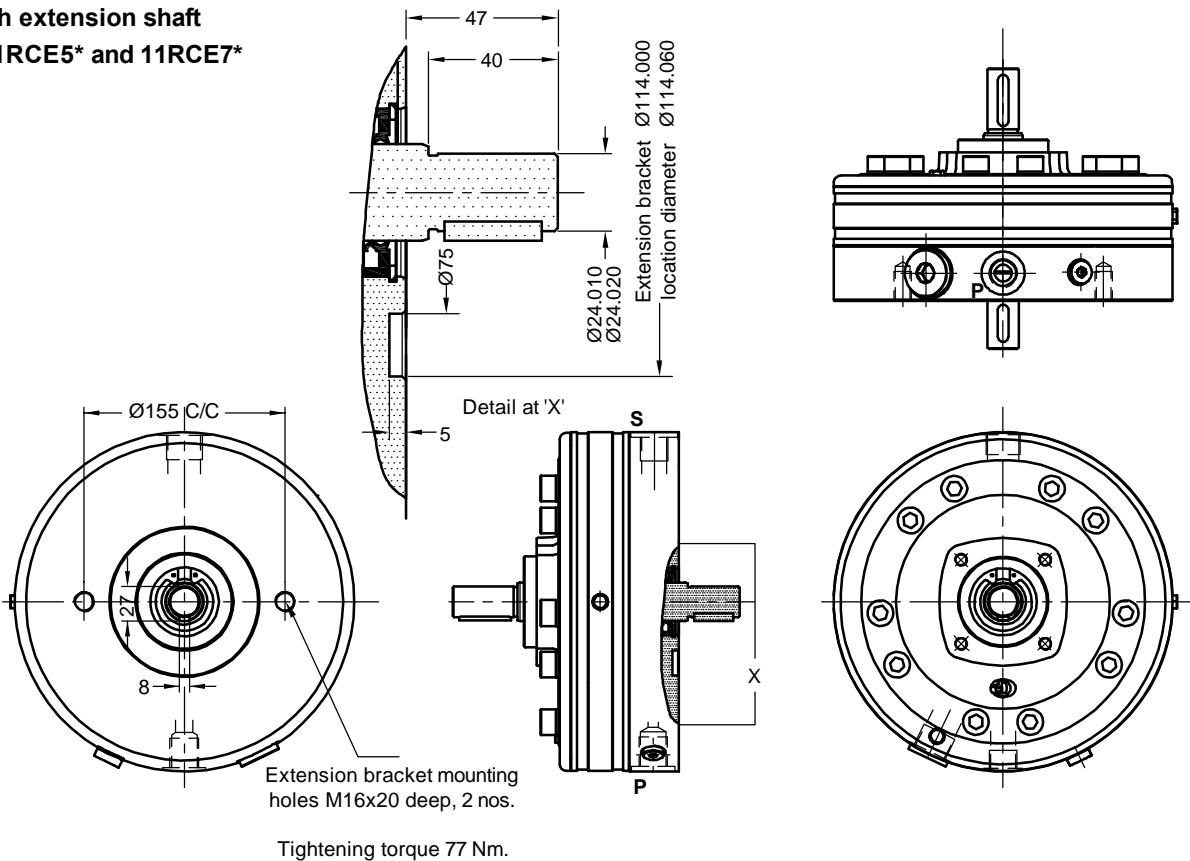



Pump with extension shaft
Model - 11RCE9*

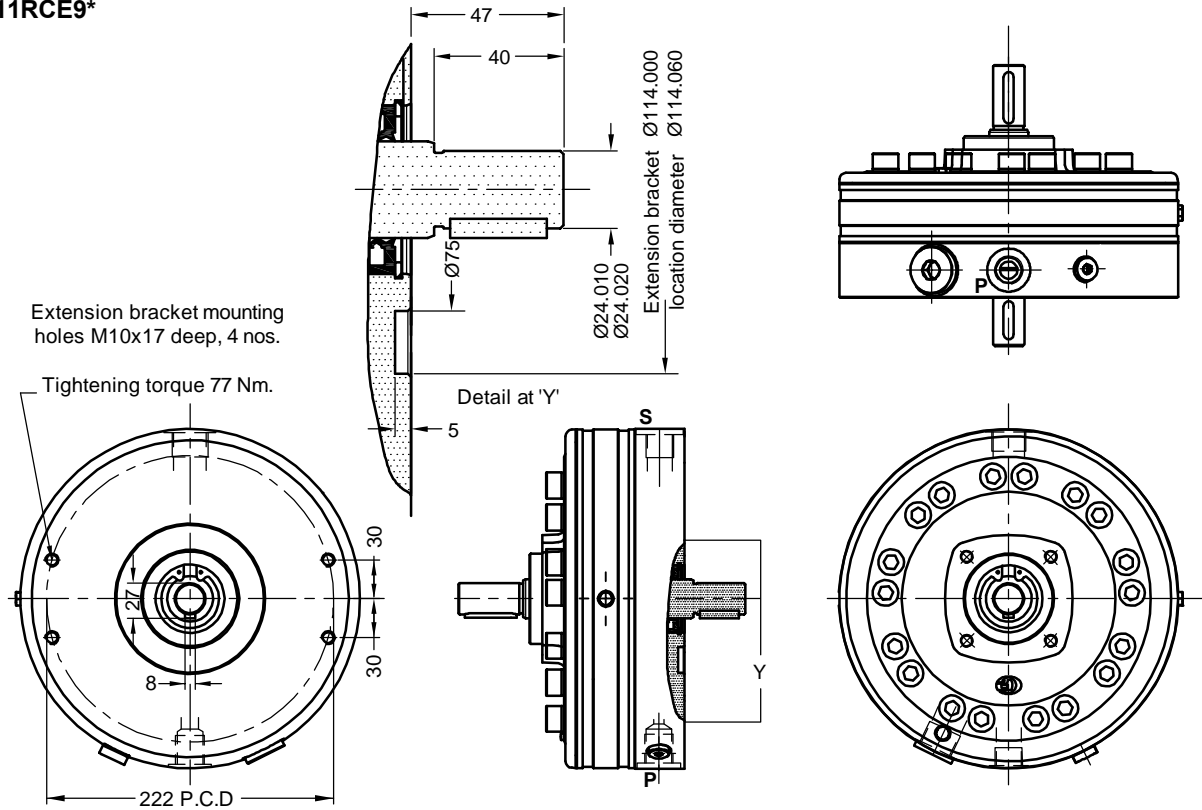

Performance : table no. 1

No. of pumping elements	Element type	Geometrical displacement in cm ³ /r	Pump output in l/min At 1450 r/min	Maximum Operating pressure in bar	Pressure in bar							
					50	100	150	200	250	300	315	400
5	A	7.70	10.5	400	1.1	2.2	3.2	4.4	5.5	6.6	6.9	8.8
7		10.78	14.7		1.5	3.1	4.6	6.1	7.7	9.2	9.6	12.2
9		13.85	18.9		2.0	3.9	5.9	7.9	9.8	11.8	12.4	15.8
5	B	10.05	13.7	315	1.4	2.9	4.3	5.7	7.1	8.6	9.0	
7		14.07	19.2		2.0	4.0	6.0	8.0	10.0	12.0	12.6	
9		18.10	24.7		2.6	5.1	7.7	10.3	12.9	15.4	16.2	
5	C	12.72	17.3	250	1.8	3.6	5.4	7.2	9.0			
7		17.81	24.3		2.5	5.1	7.6	10.1	12.6			
9		22.90	31.2		3.3	6.5	9.8	13.0	16.3			

1kW = 1.3410 hp

Note : Torque limitation : The total sum of torque applied to drive the pump and the pump attached (In case model 11RCE is used), at any given instance, should not exceed 220 Nm.

Ordering code

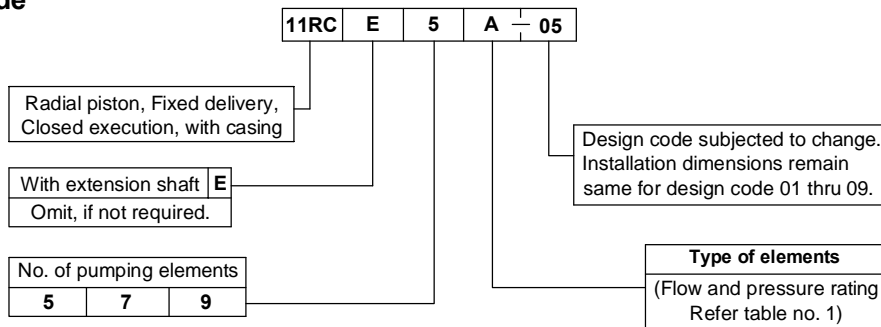

Note : For Bell housing refer Data sheet no. D 09035 and For extension bracket refer Data sheet no. D 09090. For commissioning of pump refer datasheet no. D 11200 L.

All rights reserved.
Subject to change without prior notice.
Due to continuous improvement in the design of the product, the actual product supplied may look different than shown above.
For critical applications, please ask for certified installation drawing.