



RADIAL PISTON DOUBLE PUMPS

Model : 12R****

Ref. No. D 09191
Release 12 / 2025

ENGINEERING - 1 of 3

A Polyhydron Group Company

Description

Model **12R****** are rugged oil immersed type Radial Piston Double Pumps and have either 3, 5, 7 or 9 pumping elements in each section of the pump. These pumps are valve controlled therefore there no restriction on direction of rotation of the pump.

Pumps with model code **12RE***** have extension shaft for through drive and are available with extension bracket assembly for coupling a pump having standard flanges as per ISO 3019/2 (Ref. datasheet no. D 09090).

They are available with 12 displacements and 3 pressure ratings. Flows can be combined externally to feed one circuit or can be used independently to feed two circuits.



Each section of pumps give fixed output per revolution of the shaft.

Section

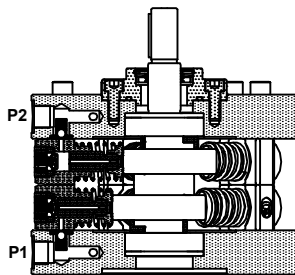

Model : 12R***

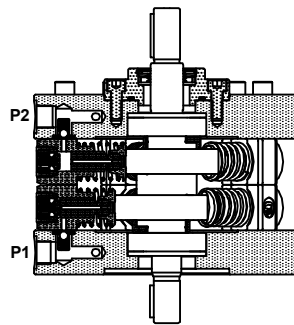

Model : 12RE***

Hydraulic symbol

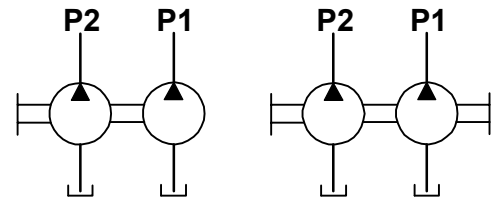

Model : 12R***

Model : 12RE***

Technical specifications

Designation	:	12R is a basic Radial piston double pump. 12RE is a Radial piston double pump with extension shaft.
Design	:	Radial piston, valve controlled, oil immersed.
No. of pumping elements	:	5, 7 or 9 each at P1 and P2 port depending upon flow requirement.
Mounting interface	:	Factory standard, face mounting.
Direction of rotation	:	12R - No restriction on directions of rotation. 12RE - Depends upon the direction rotation of pump attached.
Connection	:	Suction port - Sucks oil directly from tank, no suction port is provided. Delivery (port P1 and P2) - G1/2 female.
Speed range	:	300 to 2000 r/min.
Flow and Pressure	:	Refer Table no.1
Torque limitations	:	Input drive shaft - 220 Nm Extension shaft - 130 Nm
Hydraulic medium	:	Mineral oil.
Temperature range	:	-20°C to + 80°C.
Viscosity range	:	10 cSt to 100 cSt.
Fluid cleanliness required	:	ISO 4406 20/18/15 or better.
Mass	:	Model : 12R5 12RE5 12R7 12RE7 12R9 12RE9 Kg : 36.4 36.7 39 39.4 41.7 42



Performance : table no. 1

No. of pumping elements per section	Element type	Geometrical displacement in cm ³ /r	Pump output in l/min At 1450 r/min pre section	Maximum Operating pressure in bar	Pressure in bar							
					50	100	150	200	250	300	315	400
5	A	7.70	10.5	400	1.1	2.2	3.2	4.4	5.5	6.6	6.9	8.8
7		10.78	14.7		1.5	3.1	4.6	6.1	7.7	9.2	9.6	12.2
9		13.85	18.9		2.0	3.9	5.9	7.9	9.8	11.8	12.4	15.8
5	B	10.05	13.7	315	1.4	2.9	4.3	5.7	7.1	8.6	9.0	
7		14.07	19.2		2.0	4.0	6.0	8.0	10.0	12.0	12.6	
9		18.10	24.7		2.6	5.1	7.7	10.3	12.9	15.4	16.2	
5	C	12.72	17.3	250	1.8	3.6	5.4	7.2	9.0	1kW = 1.3410 hp		
7		17.81	24.3		2.5	5.1	7.6	10.1	12.6			
9		22.90	31.2		3.3	6.5	9.8	13.0	16.3			

Note : Torque limitation : The total sum of torque applied to drive the each section of double pump and the pump attached (In case model 12RE is used), at any given instance, should not exceed 220 Nm.

Unit dimensions

Dimensions in mm.

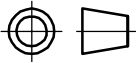

Pump without extension shaft
Model - 12R5**, 12R7** and 12R9**

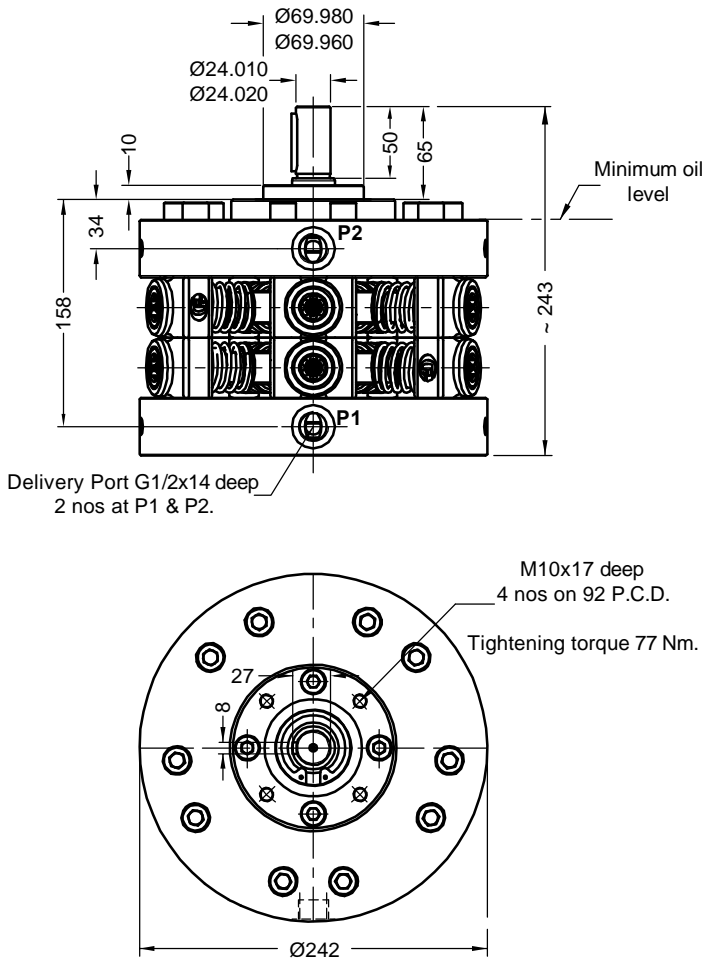

Pump with extension shaft
Model - 12RE5** and 12RE7**

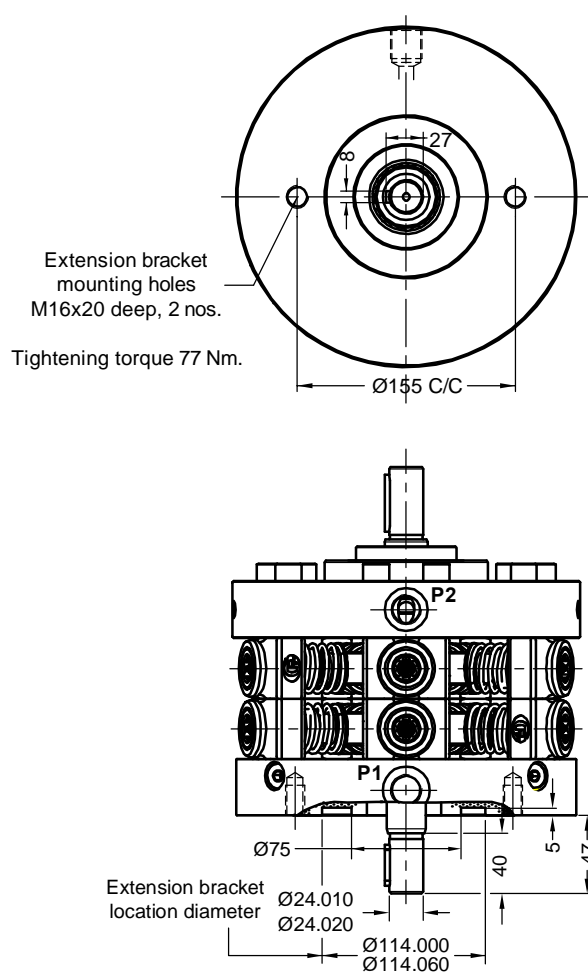



Pump with extension shaft

Model - 12RE9**

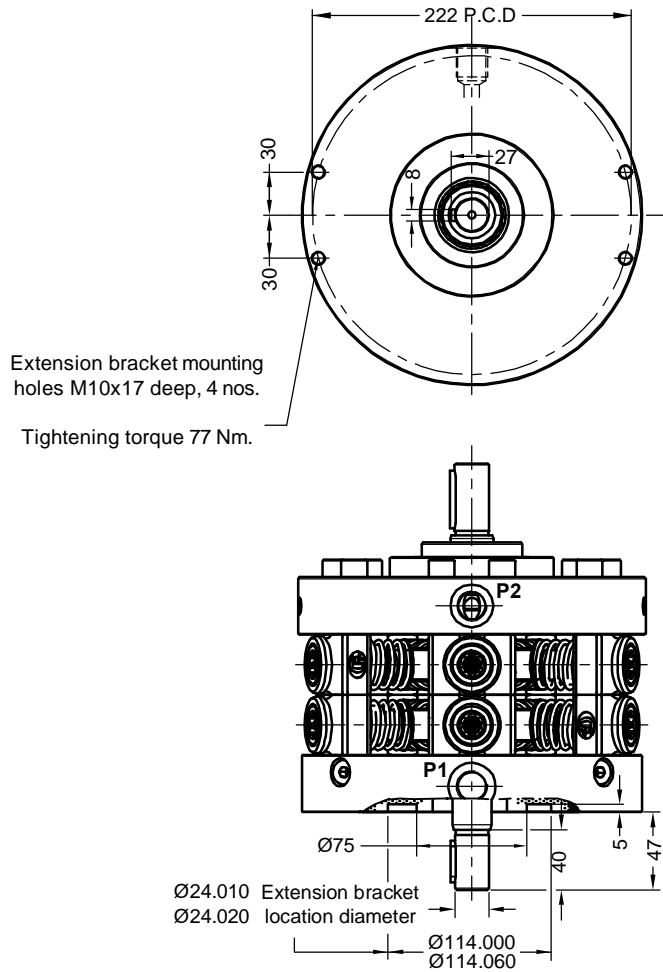

Ordering code

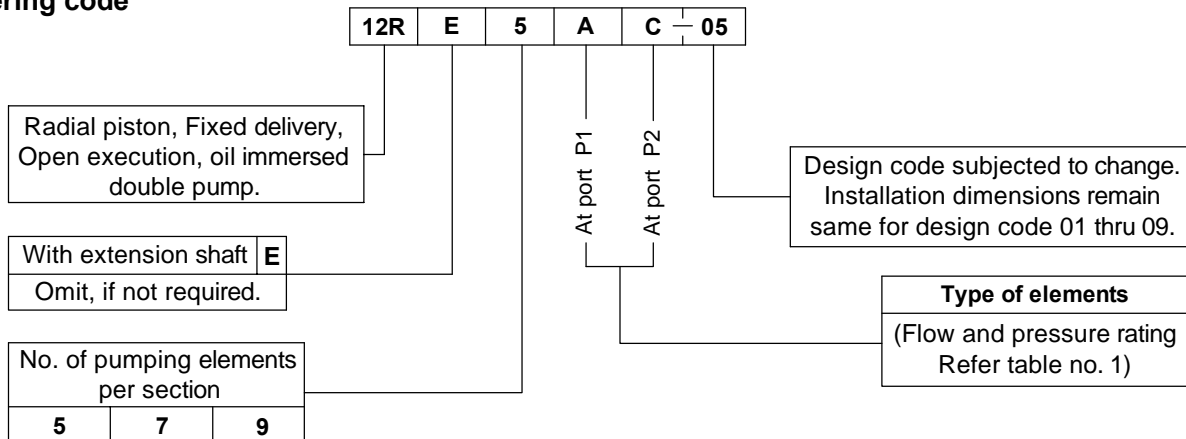

Note : For Bell housing refer Data sheet no. D 09035 and For extension bracket refer Data sheet no. D 09090.

All rights reserved.
Subject to change without prior notice.
Due to continuous improvement in the design of the product, the actual product supplied may look different than shown above.
For critical applications, please ask for certified installation drawing.