



PILOT OPERATED CHECK VALVE MODULAR CONSTRUCTION

Model : CIM06 **

Ref. No. D 05975
Release: 12 / 2025

ENGINEERING - 1 of 2

A Polyhydron Group Company

Description

Modular pilot operated check valves series CIM06** provide pressure holding facility on their service ports A1 and B1.

These valves are also available with pilot check facility on either A or B port. The valve opens and allows free return flow, when the other working port is pressurized.

The valve is not suitable for holding pressure on rod end side of Double acting cylinders, where area ratio (Bore area : Annulus area) is equal to or greater than 2.6.

The modular construction facilitates use of these valves in a vertical stack, eliminating need of piping.

The interface conforming to ISO 4401-AB-03-04-A, IS 10187, DIN24340.

Three cracking pressures : 1, 3 and 5 bar.



Section

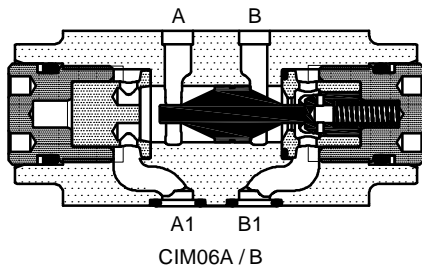
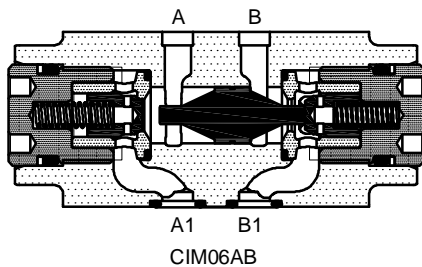

Hydraulic symbol

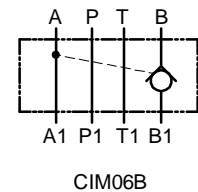
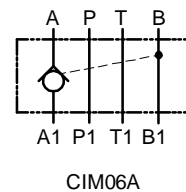
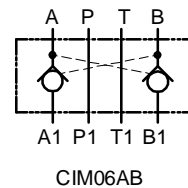

Technical specifications

Construction	:	Modular, Seat type, Internally pilot operated.
Mounting style	:	Modular type conforming to ISO 4401-AB-03-04-A, IS 10187, DIN24340.
Mounting position	:	Optional.
Flow direction	:	Free flow from A to A1 and / or from B to B1.
	:	Piloted flow in opposite direction.
Cracking pressure	:	1, 3 or 5 bar.
Working pressure	:	315 bar for all Ports.
Area ratios	:	Pilot piston : Poppet seat = 2.6 : 1
Hydraulic medium	:	Mineral oil.
Temperature range	:	-20°C to + 80°C.
Viscosity range	:	10 cSt to 380 cSt.
Fluid cleanliness required	:	ISO 4406 20/18/15 or better.
Flow handling capacity	:	Refer graph.
Mass approx.	:	0.9 Kg.

polyhydron pvt. ltd.

78-80, Machhe Industrial Estate,
Machhe, Belgaum - 590 014. INDIA.

Phone : +91-(0)831- 2411001
E-mail : sales@polyhydron.com
Website : www.polyhydron.com



Performance graph

Performance test Oil used VG-46 at 30°C.

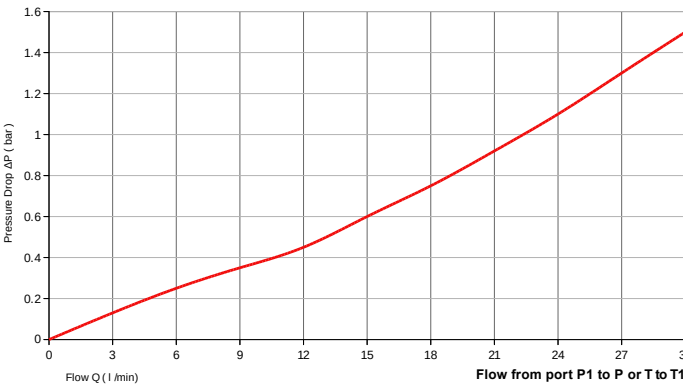
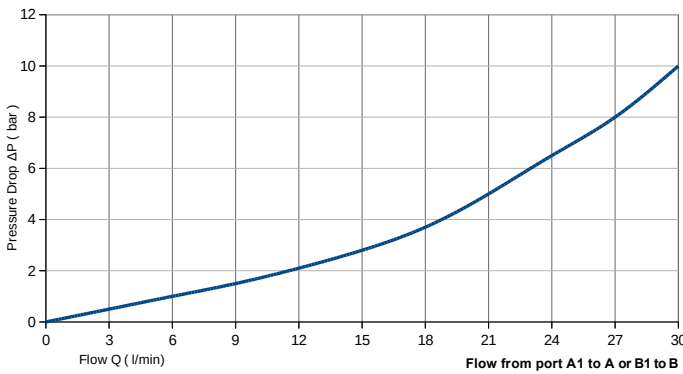
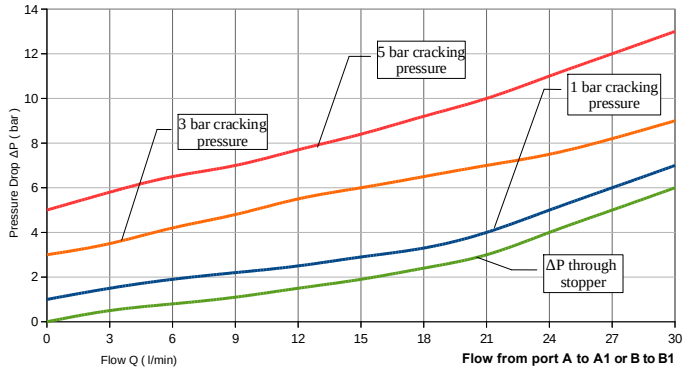

Unit dimensions

Dimensions in mm.

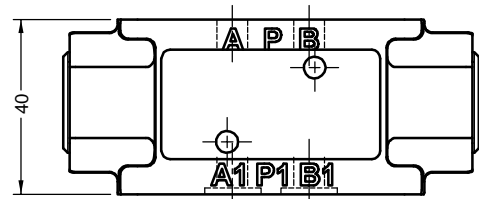
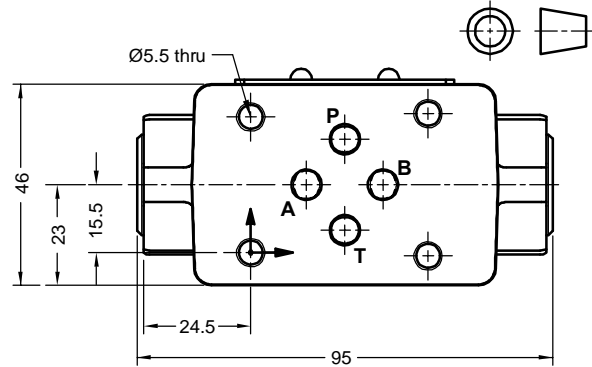

Subplate mounting interface as per ISO 4401.

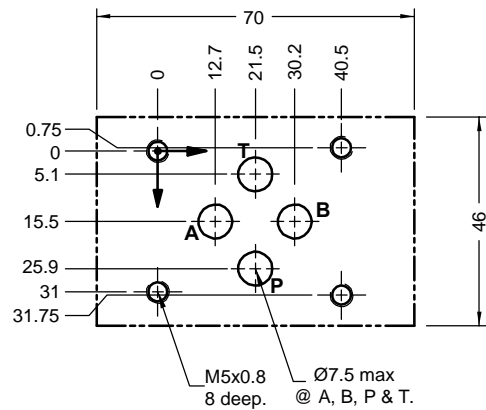

Note: Valve fixing S.H.C Screws are not in scope of supply.
Tightening torque for S.H.C Screws is 9.5 Nm.

Ordering code

CIM 06 AB 1 - 23

Pilot operated check valve modular construction

Size 06

Pilot optd. check facility	
On A & B ports	AB
On 'A' port only	A
On 'B' port only	B

Design code subjected to Change . installation dimensions remain same for design code 20 thru 29.

Cracking pressure	
1	1.0 bar
3	3.0 bar
5	5.0 bar

All rights reserved.

Subject to change without prior notice.

Due to continuous improvement in the design of the product, the actual product supplied may look different than shown above.

For critical applications, please ask for certified installation drawing.