



RADIAL PISTON PUMPS

Model : 1R****

Ref. No. D 04890
Release 03 / 2026

ENGINEERING - 1 of 3

A Polyhydron Group Company

Description

Model **1R****** are small, low weight, rugged oil immersed type Radial Piston Pumps with 2, 3, 5 or 7 pumping elements. These pumps are valve controlled and have no restriction on direction of rotation.

Pumps with model **1RE***** have extension shaft for through drive and are available with extension bracket assembly for coupling a low pressure pump having standard flange as per ISO 3019/1. Refer data sheet no. D 09090 for Extension Bracket details.

These are available with 28 displacements and 7 pressure ratings.

These pumps give fixed output per revolution of the shaft.



Section

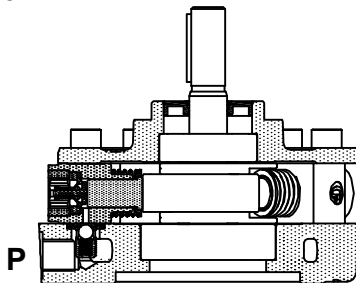

Model : 1R***

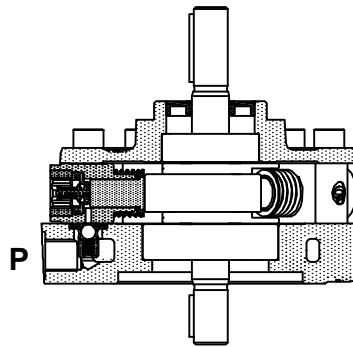

Model : 1RE***

Hydraulic symbol

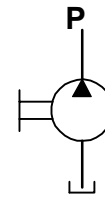

Model : 1R***

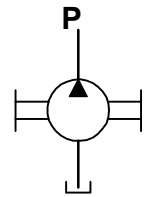

Model : 1RE***

Technical specifications

Designation	:	1R is a basic radial piston pump. 1RE is a radial piston pump with extension shaft.	
Design	:	Radial piston, valve controlled, oil immersed.	
No. of pumping elements	:	2, 3, 5 or 7.	
Mounting interface	:	Factory standard, face mounting.	
Direction of rotation	:	1R	- No restriction on directions of rotation.
		1RE	- Depends upon the direction rotation of pump attached.
Connection	:	Suction port	- Sucks oil directly from tank no suction port is provided.
		Delivery (port P)	- G3/8 female.
Speed range	:	300 to 2000 r/min.	
Flow and Pressure	:	Refer Table no.1	
Torque limitations	:	Input drive shaft	- 75 Nm
		Extension shaft	- 53 Nm
Hydraulic medium	:	Mineral oil.	
Temperature range	:	-20°C to + 80°C.	
Viscosity range	:	10 cSt to 100 cSt.	
Fluid cleanliness required	:	ISO 4406 20/18/15 or better.	
Mass	:	Model :	1RE2 1RE3 1R5 1RE5 1R7 1RE7
		Kg :	7.8 8.3 8.0 8.1 8.6 8.8



Unit dimensions

Dimensions in mm.

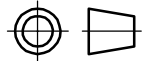

Pump without extension shaft

Model : 1R****

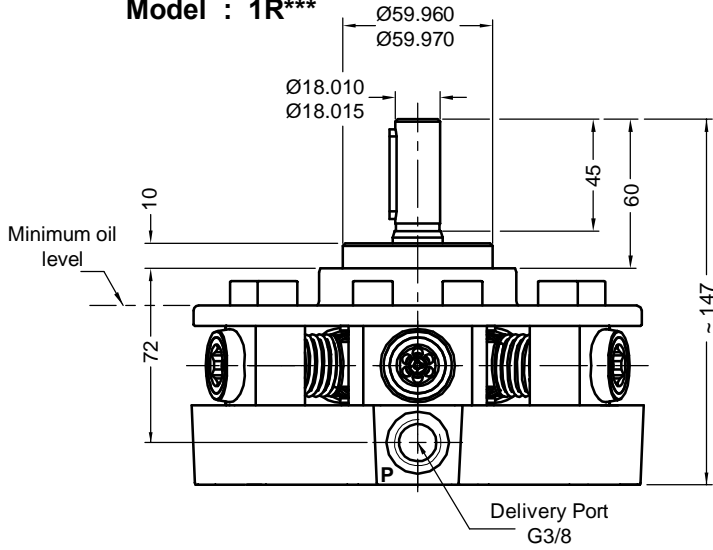

M8x12 deep,
4 nos on 80 P.C.D.

Tightening torque 39 Nm.

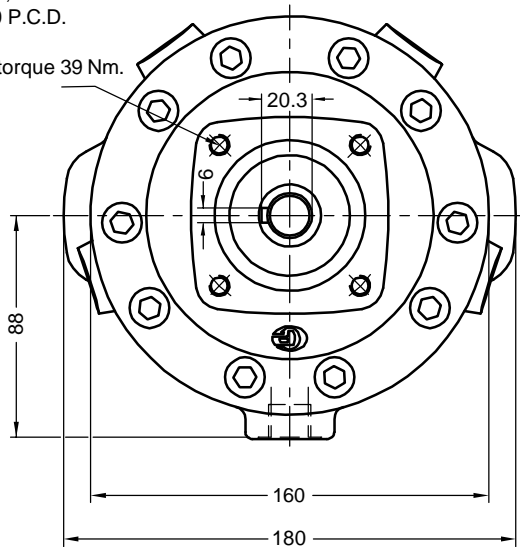

Pump with extension shaft

Model : 1RE****

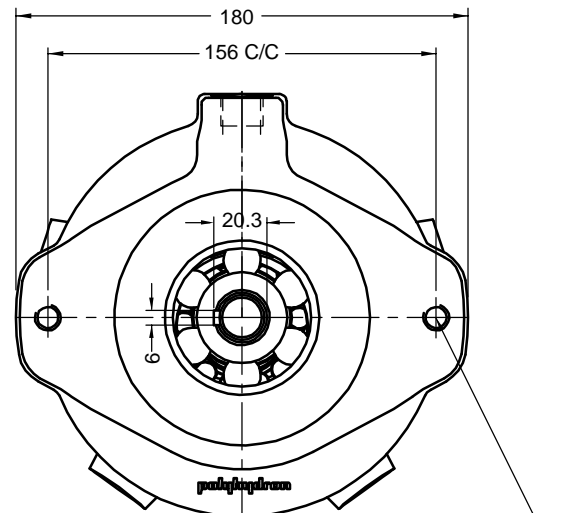

Extension bracket mounting
holes M10x17 deep, 2 nos.
Tightening torque 77 Nm.

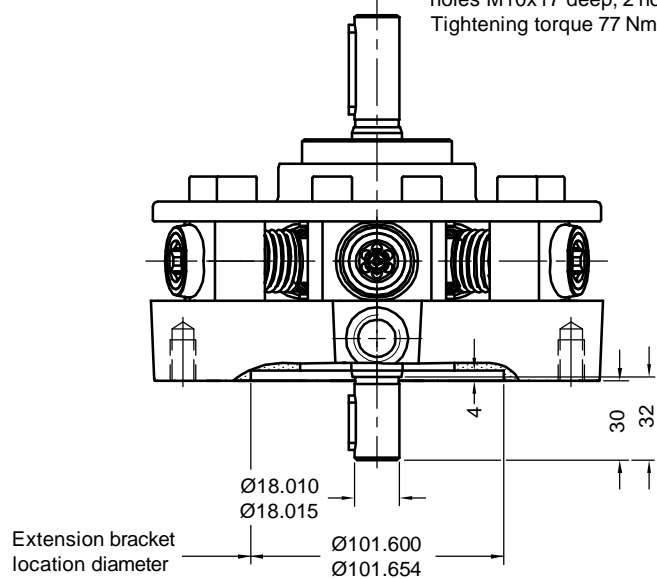



Performance: Table no. 1

No. of pumping elements	Element type	Geometrical displacement in cm ³ /r	Pump output in l/min At 1450 r/min	Maximum Operating pressure in bar	Pressure in bar													
					50	100	150	200	250	300	350	400	450	500	550	600	650	700
					Power required to drive the pump in kW													
2	Z	0.45	0.6	700	0.1	0.1	0.2	0.3	0.3	0.4	0.5	0.5	0.6	0.7	0.7	0.8	0.8	0.9
3		0.69	0.9		0.1	0.2	0.3	0.4	0.5	0.6	0.7	0.8	0.9	1.0	1.1	1.2	1.3	1.4
5		1.15	1.5		0.2	0.3	0.5	0.6	0.8	1.0	1.1	1.3	1.5	1.6	1.8	1.9	2.1	2.3
7		1.61	2.2		0.2	0.5	0.7	0.9	1.1	1.4	1.6	1.8	2.0	2.3	2.5	2.7	2.9	3.2
2	A	0.80	1.1	550	0.1	0.2	0.3	0.5	0.6	0.7	0.8	0.9	1.0	1.1	1.3			
3		1.20	1.6		0.2	0.3	0.5	0.7	0.9	1.0	1.2	1.4	1.5	1.7	1.9			
5		2.00	2.7		0.3	0.6	0.7	1.1	1.4	1.7	2.0	2.3	2.6	2.9	3.1			
7		2.80	3.8		0.4	0.8	1.2	1.6	2.0	2.4	2.8	3.2	3.6	4.0	4.4			
2	B	1.25	1.7	450	0.2	0.4	0.5	0.7	0.9	1.1	1.3	1.4	1.6					
3		1.89	2.6		0.3	0.8	0.8	1.1	1.3	1.6	1.9	2.1	2.4					
5		3.15	4.3		0.5	0.9	1.3	1.8	2.2	2.7	3.1	3.6	4.0					
7		4.41	6.0		0.6	1.3	1.9	2.5	3.1	3.8	4.4	5.0	5.6					
2	C	1.80	2.5	350	0.3	0.5	0.8	1.0	1.3	1.5	1.8							
3		2.70	3.7		0.4	0.8	1.2	1.5	1.9	2.3	2.7							
5		4.50	6.2		0.6	1.3	1.9	2.6	3.2	3.9	4.5							
7		6.30	8.6		0.9	1.8	2.7	3.6	4.5	5.4	6.3							
2	D	2.12	2.9	300	0.3	0.6	0.9	1.2	1.5	1.8								
3		3.18	4.3		0.5	0.9	1.4	1.8	2.3	2.7								
5		5.30	7.2		0.8	1.5	2.3	3.0	3.8	4.5								
7		7.42	10.1		1.1	2.1	3.2	4.2	5.3	6.3								
2	E	2.46	3.4	250	0.4	0.7	1.1	1.4	1.8									
3		3.69	5.0		0.5	1.1	1.6	2.1	2.6									
5		6.15	8.4		0.9	1.8	2.6	3.5	4.4									
7		8.61	11.7		1.2	2.5	3.7	4.9	6.1									
2	F	2.82	3.9	200	0.4	0.8	1.2	1.6										
3		4.23	5.8		0.6	1.2	1.8	2.4										
5		7.05	9.6		1.0	2.0	3.0	4.0										
7		9.87	13.5		1.4	2.8	4.2	5.6										

1kW = 1.34 hp

Ordering code

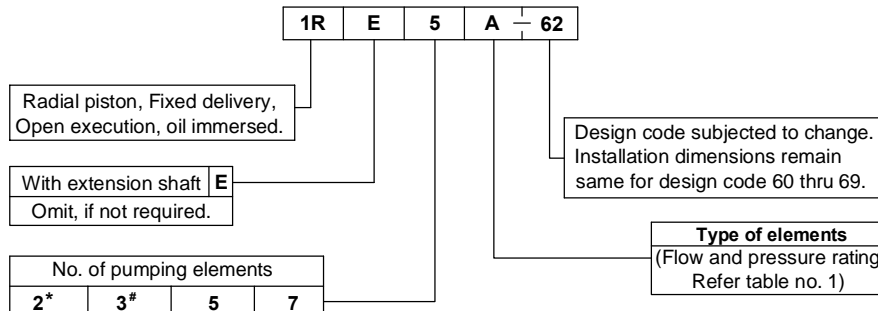

Note : For Bell housing refer Data sheet no. D 09035 and For extension bracket refer Data sheet no. D 09090.
For 3 pumping element pump without extension shaft refer datasheet no. D 04931.
* For 2 pumping element pump without extension shaft refer datasheet no. D 11200.

All rights reserved.
Subject to change without notice.
Due to continuous improvements in the design of the product, the actual product supplied may look different than shown above, but will have same mounting dimensions.
For critical applications, please ask for certified installation drawing.

All rights reserved.
Subject to revision