



RELIEF CUM UNLOADING COVER

Model : CVC*U

Ref. No. D 03419
Release 11 / 2025

ENGINEERING - 1 of 2

A Polyhydon Group Company

Description

The Covers **CVC*U** are designed to hold Polyhydon make 2 port slip-in cartridge valves model **CV***** in the cavities machined as per ISO 7368, and are meant to create a pilot operated relief cum Unloading function when combined with a slip-in cartridge having a poppet area ratio of 1:1. Here the unloading is achieved by an external pressure, applied to its Z1 port.

Hence, as long as the pressure at port Z1 is equal to or above the set pressure on the relief valve in the cover, the valve unloads the pump. In case the pressure at Z1 is less than the set pressure, then the combination responds to the pressure at port A of the slip-in cartridge, limiting it at the set pressure by relieving action.

In addition, these covers are also available with an optional facility to mount Solenoid operated Directional Control Valve to give the combination an added feature of unloading the pump by means of an electrical signal to the Solenoid.

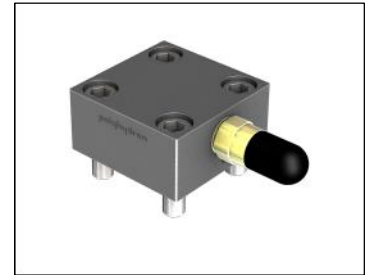

Section

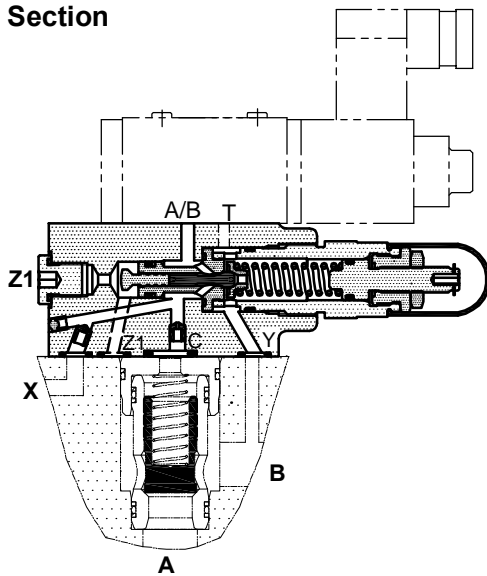

Hydraulic symbol

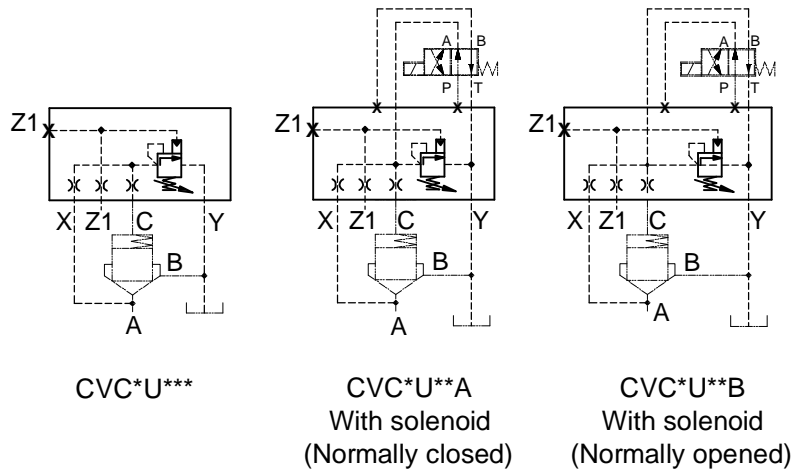

Technical specifications

Mounting interface	:	As per ISO 7368
Working pressure	:	350 bar.
Hydraulic medium	:	Mineral oil.
Temperature range	:	-20°C to + 80°C.
Viscosity range	:	10 cSt to 380 cSt.
Fluid cleanliness required	:	ISO 4406 20/18/15 or better.



Unit dimensions

Dimensions in mm.

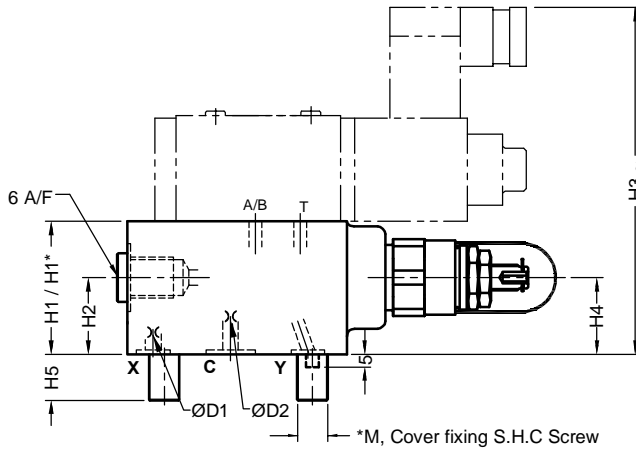
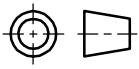

Cover mounting interface as per ISO 7368.

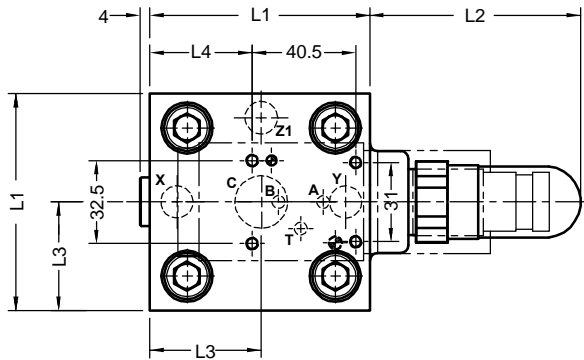
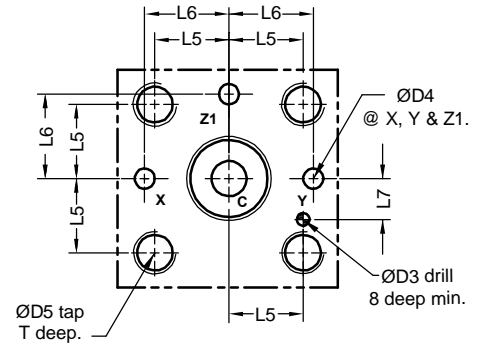

Notes:

- Cover fixing S.H.C Screws are **OUT OF SCOPE OF SUPPLY.**
- Mounting interface for Soln. D.C.V as per ISO 4401-03-02.

Size	Mass Kg. approx	L1	L2	L3	L4	L5	L6	L7	ØD1	ØD2	ØD3	ØD4 max	ØD5	T	H1	H1*	H2	H3	H4	H5	*M. 4 nos. Cover fixing S.H.C. Screw (Class 12.9)	Tightening Torque.
16	2.5	67	91.5	33.5	25.5	23	25	10.5	0.8	1	4	4	M8	14	53	53	30	158	30	12	M8 x 40 Long	39 Nm
25	4.0	85	82.5	42.5	40	29	33	16	0.8	1	6	6	M12	20	52	52	30	157	30	18	M12 x 45 Long	135 Nm
32	5.0	102	67.5	51	37.5	35	41	17	1.2	1.2	6	8	M16	26	50	58	30	163	30	24	M16 x 55 Long	330 Nm
40	8.0	125	67.5	62.5	61	42.5	50	23	1.2	1.2	6	10	M20	33	60	60	35	165	35	30	M20 x 70 Long	650 Nm

Please consider height **H1*** for covers having mounting provision for solenoid directional control valve.

Ordering code

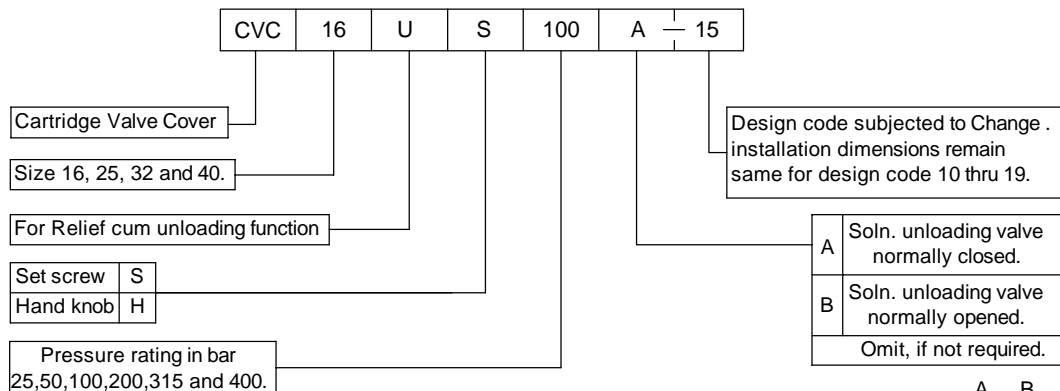

Note : Solenoid (refer spool type) to be ordered separately.

