



A Polyhydron Group Company

PRESSURE SWITCH

Model : 1PS / 1PF

Ref. No. D 90100
Release 01/2026

ENGINEERING - 1 of 4

Description

Non adjustable differential type.

Spring loaded sealed piston construction.
Encapsulated design for protection against dust.

Six pressure ranges available, which can be adjustable upto 10, 50, 100, 200, 350 and 420 bar.

Transparent plug-in connector is available with LED.



Unit dimensions

Dimensions in mm.

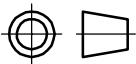

Hydraulic Symbol

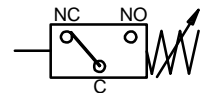

Mounting type : **Subplate Mounting**

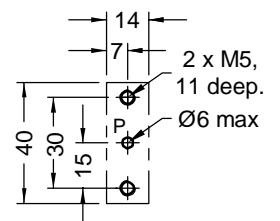
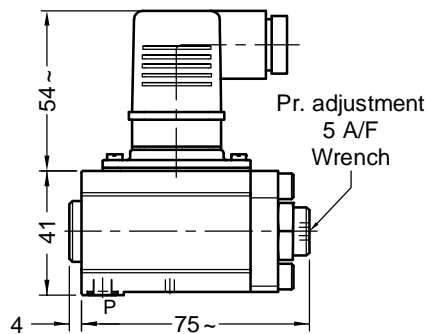
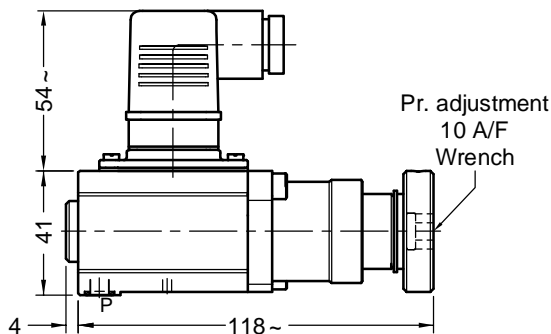

Mounting Interface for 1PS & 1PS10

Mounting screw
M5 x 50 L, 2 nos.
Tightening Torque 7 Nm.

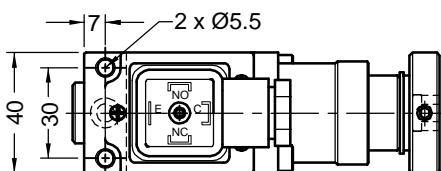

MODEL : 1PS

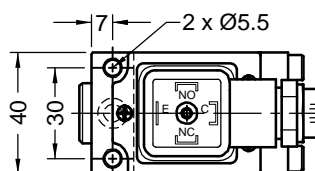

MODEL : 1PS10



Mounting type : Face Mounting

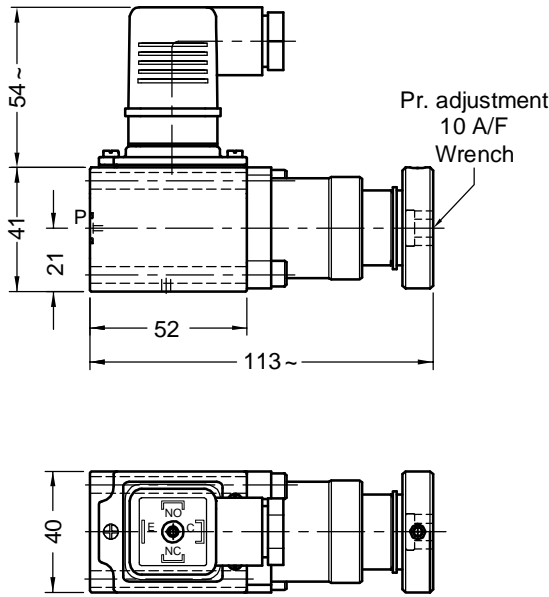

MODEL : 1PF

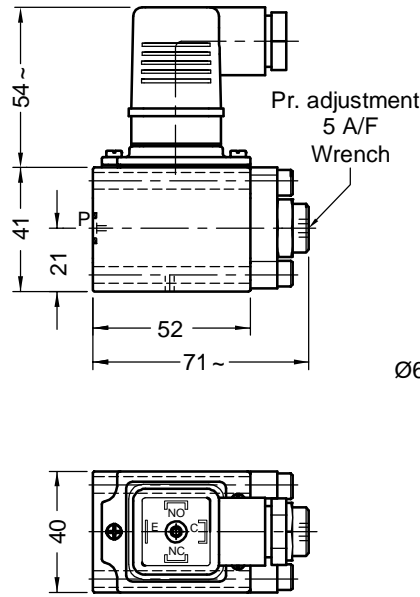

MODEL : 1PF10

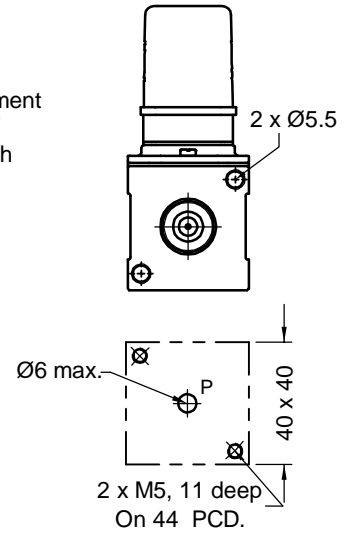

Mounting Interface for
1PF & 1PF10

Mounting screw
M5 x 60 L, 2 nos.
Tightening Torque 7 Nm.

Technical Specifications

Construction	Spring loaded sealed piston type.
Mounting style	Subplate mounting.
Interface	Factory standard.
Mounting position	optional.
Hydraulic medium	Mineral oil.
Viscosity range	10cSt to 100 cst.
Oil cleanliness requirement.....	As per ISO 4406 Code 20/18/15 or better.
Max operating pressure	Refer Table no 1.
Pressure range available	Adjustable upto 10, 50,100, 200, 350 and 420 bar.
Switching pressure differential.....	Refer graph.
Switching Frequency	80 Cycles / min.
Life	1 million cycles minimum.
Electrical rating	UL / C - UL rating 6A, 125 / 250 VAC.
	EN / EC rating 6(3)A, 250 V ~ 5E4 T85, μ approved.
Electrical connector	Plug - in connector conforms to DIN 43650, ISO 4400.
Mass.....	Pressure Switch.....

	1PS	1PS10	1PF	1PF10
	0.43 kg.	0.37 kg.	0.41 kg.	0.35 kg.

Subplate..... 0.125 kg.

Table No. 1

Pressure Setting (bar).....

Model		Increasing pr.		Decreasing pr.		Operting pr.
		min	max	min	max	max
1PS10/1PF10	1P*10	4	10	2.5	7	100
	1P*50	8	50	5	44	420
1PS/1PF	1P*100	14	100	10	90	
	1P*200	20	200	15	185	
	1P*350	25	350	20	330	
	1P*420	28	420	22	390	



Subplate 1PS / 1PS10

Ordering code : **1SPSG02**

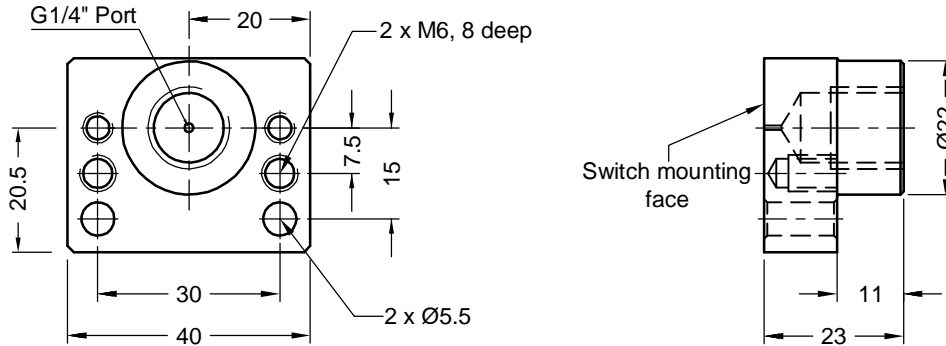

Ordering code

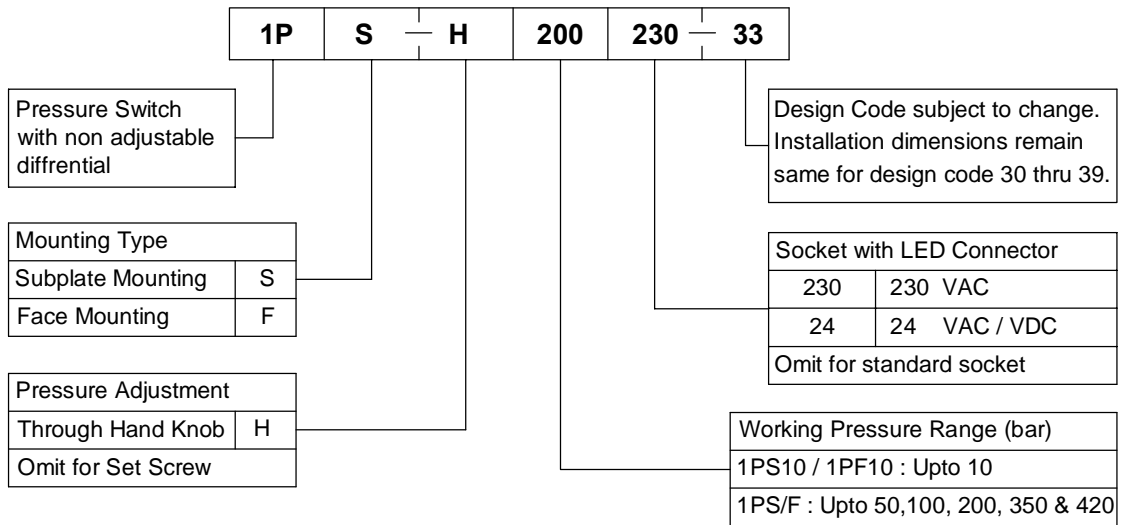

NOTE : Subplate to be ordered separately (refer subplate ordering code above).



Switching pressure differential

X : Min Pressure Differential
Y : Max Pressure Differential

1PS/F 10

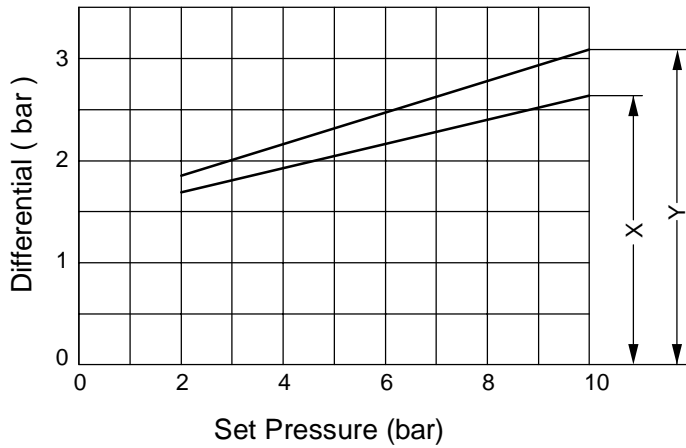

1PS/F 50

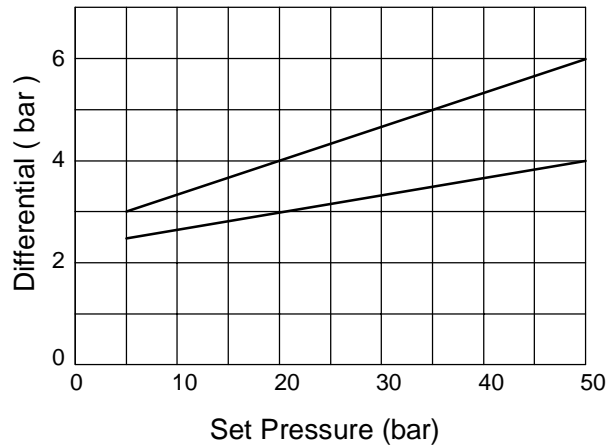

1PS/F 100

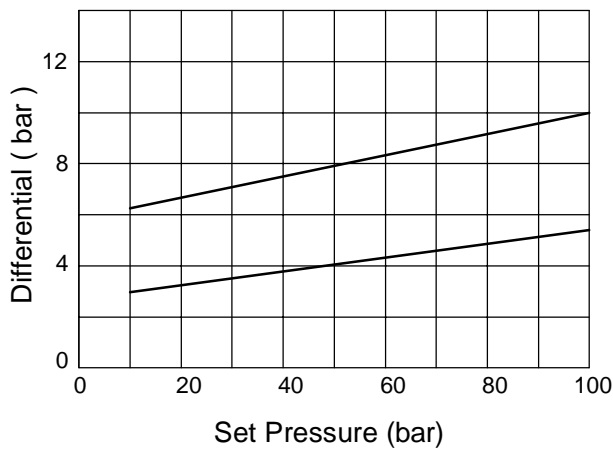

1PS/F 200

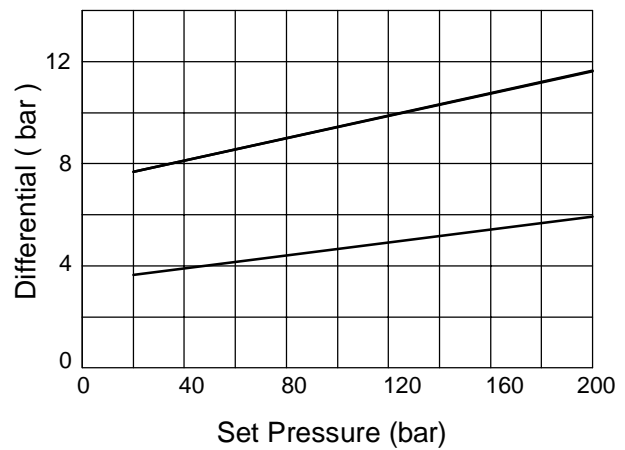

1PS/F 350

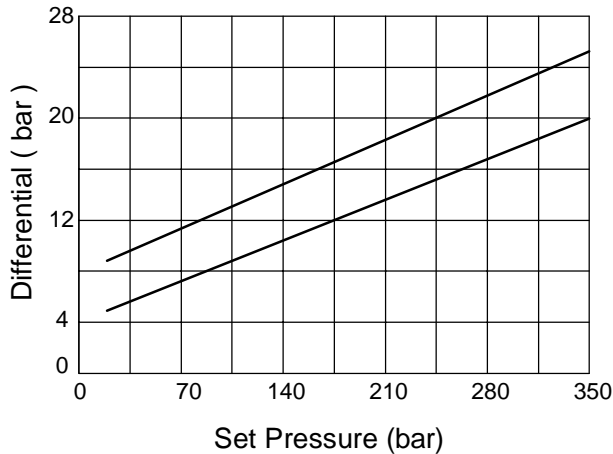

1PS/F 420

