



RADIAL PISTON PUMPS Model : 1R2**

Ref. No. D 11200
Release 12 / 2025

ENGINEERING - 1 of 2

A Polyhydron Group Company

Description

Pumps model 1R2** are small, low weight, rugged oil immersed type Radial Piston Pumps. These pumps are valve controlled and there is no restriction on direction of rotation of the pump.

These are available with 7 displacements and 7 pressure ratings.

These pumps give fixed output per revolution of the shaft.



Section

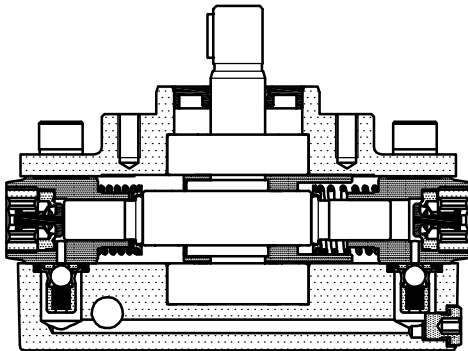

Hydraulic symbol

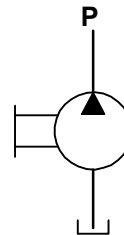

Technical specifications

Designation	:	1R is a basic radial piston pump group.
Design	:	Radial piston, valve controlled, oil immersed.
No. of elements	:	2.
Mounting interface	:	Factory standard, face mounting.
Direction of rotation	:	No restriction on directions of rotation.
Connection	:	Suction port - Sucks oil directly from tank no suction port is provided. Must be always immersed in oil.
		Delivery (port P) - G1/4 female.
Speed range	:	300 to 2000 r/min.
Flow and Pressure	:	Refer Table no.1
Hydraulic medium	:	Mineral oil.
Temperature range	:	-20°C to + 80°C.
Viscosity range	:	10 cSt to 100 cSt.
Fluid cleanliness required	:	ISO 4406 20/18/15 or better.
Mass	:	4.4 Kg.



Unit dimensions

Dimensions in mm.

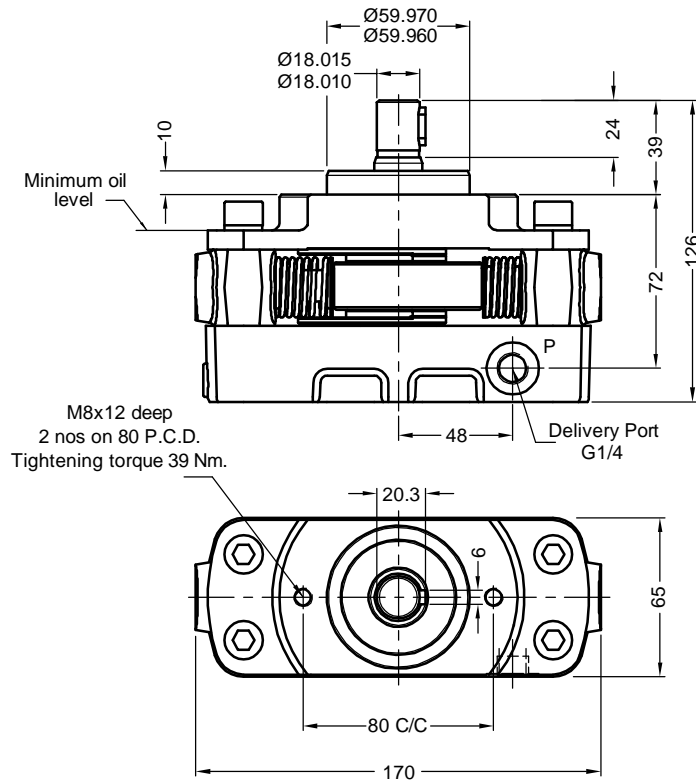
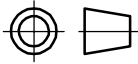

Performance Table no. 1

No. and type of Elements	Geometrical displacement in cm ³ /r	Pump output in l/min at 1450 r/min	Max. rated pressure	Input power required at pressure in bar													
				50	100	150	200	250	300	350	400	450	500	550	600	650	700
	cm ³ /r	l/min.	bar	Power (kW)													
2 Z	0.45	0.6	700	0.1	0.1	0.2	0.3	0.3	0.4	0.5	0.5	0.6	0.6	0.7	0.8	0.8	0.9
2 A	0.80	1.1	550	0.1	0.2	0.3	0.5	0.6	0.7	0.8	0.9	1.0	1.1	1.3			
2 B	1.25	1.7	450	0.2	0.4	0.5	0.7	0.9	1.1	1.3	1.4	1.6					
2 C	1.80	2.5	350	0.3	0.5	0.8	1.0	1.3	1.5	1.8							
2 D	2.12	2.9	300	0.3	0.6	0.9	1.2	1.5	1.8								
2 E	2.46	3.4	250	0.4	0.7	1.1	1.4	1.8									
2 F	2.82	3.9	200	0.4	0.8	1.2	1.6										

1kW = 1.3410 hp

Ordering code

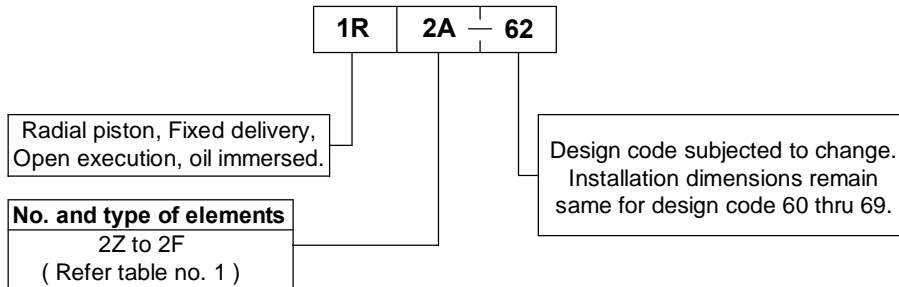

Note : For Bell housing refer Data sheet no. D 09035.

All rights reserved.
Subject to change without notice.
Due to continuous improvement in the design of the product, the actual product supplied may look different than shown above.
For critical applications, please ask for certified installation drawing.